

A2D250-AA02-64

# AC axial fan

straight blades (A series), single-intake



A2D250-AA02-64 ebmpapst Datasheet

sales@fansco.com

www.fansco.com

Limited partnership · Headquarters Muldingen

Amtsgericht (court of registration) Stuttgart · HRA 590344

General partner Elektrobau Muldingen GmbH · Headquarters Muldingen

Amtsgericht (court of registration) Stuttgart · HRB 590142



## Nominal data

Type	A2D250-AA02-64		
Motor	M2D068-DF		
Phase		3~	3~
Nominal voltage	VAC	400	400
Wiring		Y	Y
Frequency	Hz	50	60
Method of obtaining data		fa	fa
Valid for approval/standard		CE	CE
Speed (rpm)	min <sup>-1</sup>	2650	2950
Power consumption	W	110	160
Current draw	A	0.22	0.26
Max. back pressure	Pa	250	300
Max. back pressure	inH <sub>2</sub> O	1	1.2
Min. ambient temperature	°C	-25	-25
Max. ambient temperature	°C	90	60

ml = Max. load · me = Max. efficiency · fa = Free air · cs = Customer specification · ce = Customer equipment  
Subject to change

## Data according to ErP Directive

		Actual	Req. 2015			
01 Overall efficiency $\eta_{es}$	%	28.1	28.1	09 Power consumption $P_e$	kW	0.13
02 Measurement category		A		09 Air flow $q_v$	m <sup>3</sup> /h	1050
03 Efficiency category		Static		09 Pressure increase $p_{fs}$	Pa	121
04 Efficiency grade N		40	40	10 Speed (rpm) n	min <sup>-1</sup>	2600
05 Variable speed drive		No		11 Specific ratio*		1.00

Data obtained at optimum efficiency level.  
The ErP data is determined using a motor-impeller combination in a standardized measurement setup.

\* Specific ratio =  $1 + p_g / 100\,000\text{ Pa}$

LU-69121



### Technical description

Weight	2.2 kg
Fan size	250 mm
Rotor surface	Unpainted
Blade material	Sheet steel, galvanized
Number of blades	5
Airflow direction	"V"
Direction of rotation	Counterclockwise, viewed toward rotor
Degree of protection	IP44; installation- and position-dependent as per EN 60034-5
Insulation class	"F"
Moisture (F) / Environmental (H) protection class	H0+
Max. permitted ambient temp. for motor (transport/storage)	+ 80 °C
Min. permitted ambient temp. for motor (transport/storage)	- 40 °C
Installation position	Shaft horizontal or rotor on bottom; rotor on top on request
Condensation drainage holes	On rotor side
Mode	S1
Motor bearing	Ball bearing
Touch current according to IEC 60990 (measuring circuit Fig. 4, TN system)	< 0.75 mA
Motor protection	Thermal overload protector (TOP) with basic insulation
With cable	Lateral
Protection class	I (with customer connection of protective earth)
Conformity with standards	EN 60335-1; CE

# AC axial fan

straight blades (A series), single-intake

Product drawing

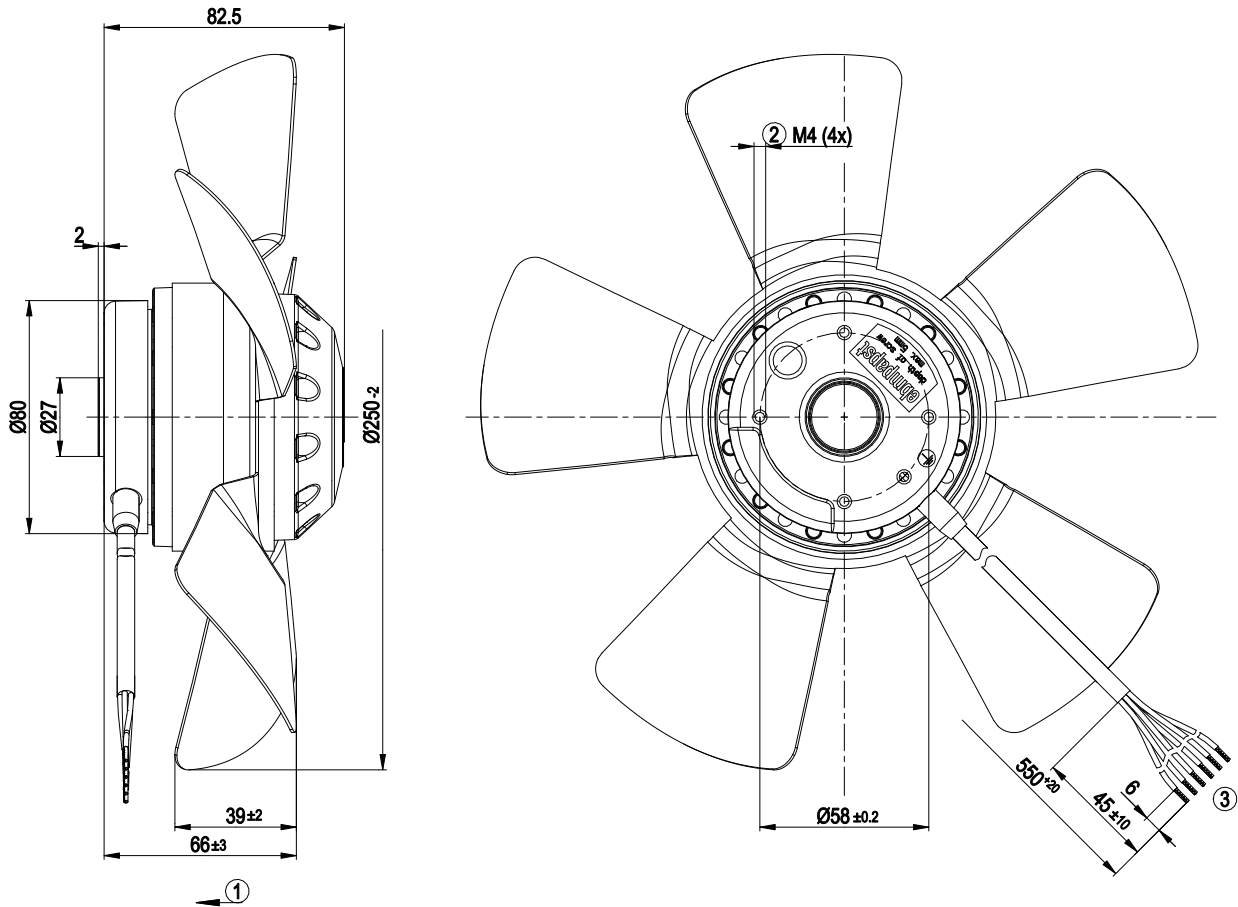

1	Direction of air flow "V"
2	Max. clearance for screw 5 mm
3	Cable XLPE/XLPO 6G 0.5 mm <sup>2</sup> , 6x crimped splices



## Connection diagram

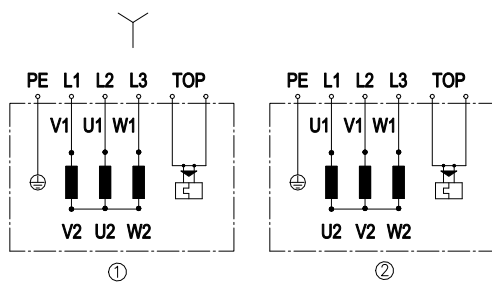

Change of rotation direction by reversing two phases

	Three-phase motor
Y	Star connection
1	Counterclockwise operation
L1	= V1 = blue
L2	= U1 = black
L3	= W1 = brown
2	Clockwise operation
L1	= U1 = black
L2	= V1 = blue
L3	= W1 = brown
PE	green/yellow
TOP	2x gray

## Curves: Air performance 50 Hz Y

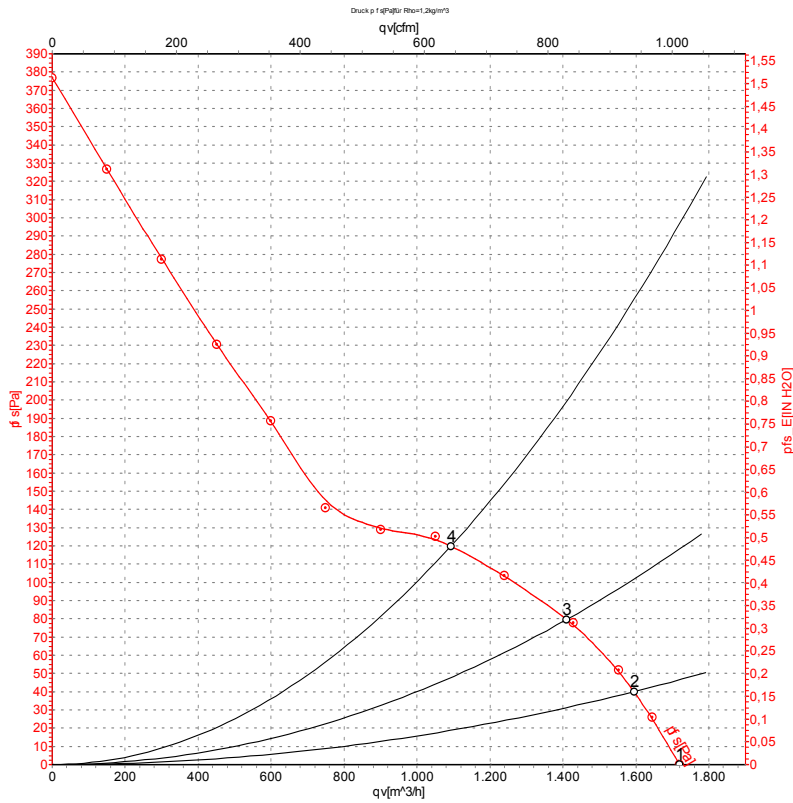

Measurement: LU-69121-1

Air performance measured according to ISO 5801 installation category A. For detailed information on the measurement setup, contact ebmpapst. Intake sound level: Sound power level according to ISO 13347 / sound pressure level measured at 1 m distance from fan axis. The values given are valid under the specified measuring conditions and may vary due to conditions of installation. For deviations from the standard configuration, the parameters have to be checked on the installed unit.

## Measured values

	Wired	U	f	n	P <sub>e</sub>	I	qv	p <sub>fs</sub>	qv	p <sub>fs</sub>
		V	Hz	min <sup>-1</sup>	W	A	m <sup>3</sup> /h	Pa	CFM	inH2O
1	Y	400	50	2650	110	0.22	1720	0	1010	0.00
2	Y	400	50	2620	126	0.23	1595	40	940	0.16
3	Y	400	50	2600	131	0.24	1410	80	830	0.32
4	Y	400	50	2595	131	0.24	1090	120	645	0.48

Wired = Wiring · U = Power supply · f = Frequency · n = Speed (rpm) · P<sub>e</sub> = Power consumption · I = Current draw · qv = Air flow · p<sub>fs</sub> = Pressure increase



## Curves: Air performance 60 Hz Y

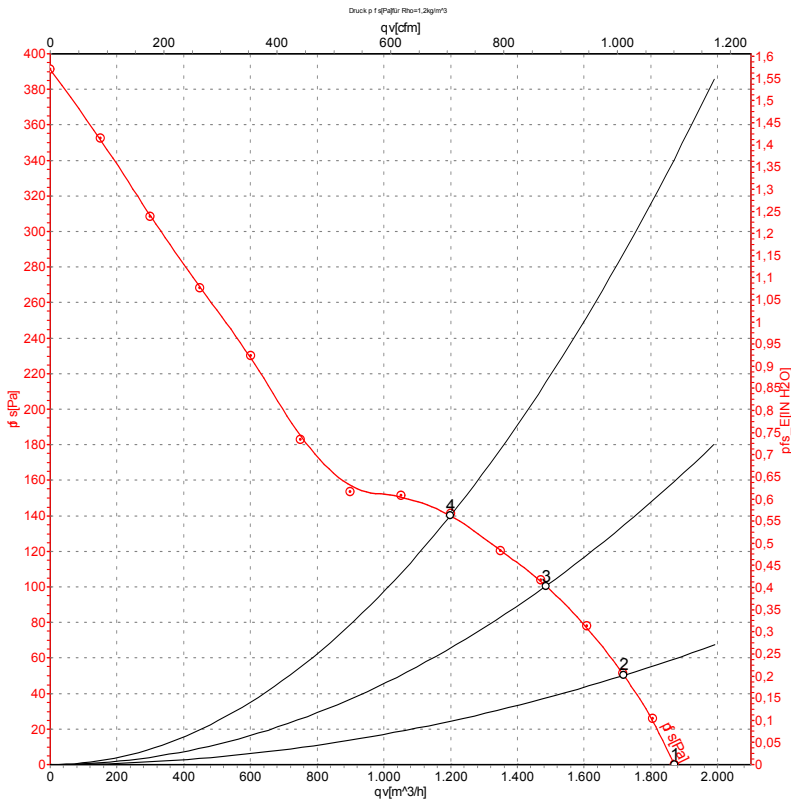

Measurement: LU-69123-1

Air performance measured according to ISO 5801 installation category A. For detailed information on the measurement setup, contact ebmpapst. Intake sound level: Sound power level according to ISO 13347 / sound pressure level measured at 1 m distance from fan axis. The values given are valid under the specified measuring conditions and may vary due to conditions of installation. For deviations from the standard configuration, the parameters have to be checked on the installed unit.

## Measured values

	Wired	U	f	n	P <sub>e</sub>	I	qv	p <sub>fs</sub>	qv	p <sub>fs</sub>
		V	Hz	min <sup>-1</sup>	W	A	m <sup>3</sup> /h	Pa	CFM	inH <sub>2</sub> O
1	Y	400	60	2950	160	0.26	1870	0	1100	0.00
2	Y	400	60	2850	177	0.28	1720	50	1010	0.20
3	Y	400	60	2810	184	0.29	1485	100	875	0.40
4	Y	400	60	2805	184	0.29	1200	140	705	0.56

Wired = Wiring · U = Power supply · f = Frequency · n = Speed (rpm) · P<sub>e</sub> = Power consumption · I = Current draw · qv = Air flow · p<sub>fs</sub> = Pressure increase

