

# AC axial fan

straight blades (A series)

A2D210-AA02-10 ebmpapst Datasheet  
 sales@fansco.com  
 www.fansco.com

Limited partnership · Headquarters Mulfingen  
 Amtsgericht (court of registration) Stuttgart · HRA 590344  
 General partner Elektrobau Mulfingen GmbH · Headquarters Mulfingen  
 Amtsgericht (court of registration) Stuttgart · HRB 590142

## Nominal data

<b>Type</b>	<b>A2D210-AA02-10</b>		
<b>Motor</b>	<b>M2D068-CF</b>		
Phase		3~	3~
Nominal voltage	VAC	400	400
Wiring		Y	Y
Frequency	Hz	50	60
Method of obtaining data		fa	fa
Valid for approval/standard		-	-
Speed (rpm)	min <sup>-1</sup>	2750	3100
Power consumption	W	60	81
Current draw	A	0.15	0.15
Min. ambient temperature	°C	-25	-25
Max. ambient temperature	°C	-	-

ml = Max. load · me = Max. efficiency · fa = Free air · cs = Customer specification · ce = Customer equipment  
 Subject to change



## Technical description

Weight	1.7 kg
Size	210 mm
Motor size	68
Rotor surface	Unpainted
Blade material	Sheet steel, galvanized
Number of blades	5
Airflow direction	V
Direction of rotation	Counterclockwise, viewed toward rotor
Degree of protection	IP54
Insulation class	"B"
Moisture (F) / Environmental (H) protection class	H0+; F1-1
Max. permitted ambient temp. for motor (transport/storage)	+ 80 °C
Min. permitted ambient temp. for motor (transport/storage)	- 40 °C
Installation position	Any
Condensation drainage holes	None
Mode	S1
Motor bearing	Ball bearing
Touch current according to IEC 60990 (measuring circuit Fig. 4, TN system)	< 0.75 mA
With cable	Lateral
Protection class	I (if the protective earth is connected by the customer to the marked PE connection point)
Conformity with standards	EN 60335-1, motor does not have factory-installed overheating protection
Approval	CCC

Product drawing

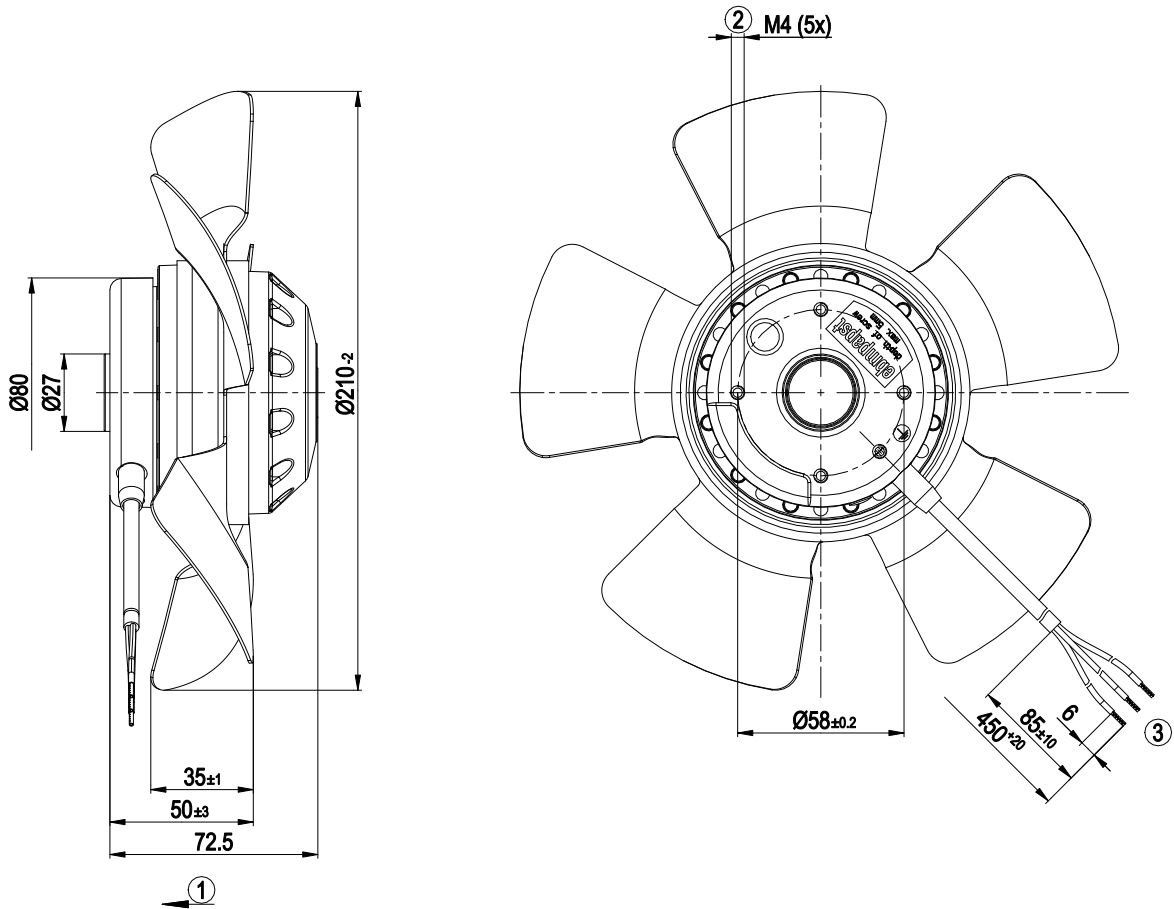

1	Airflow direction "V"
2	Max. clearance for screw 5 mm
3	Cable silicone 3x 0.5 mm <sup>2</sup>
	3x splice

## Connection diagram

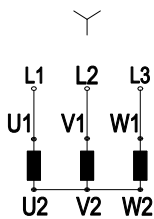

Note: Change of rotation direction by reversing two phases

Y	Star connection	L1	black	L2	blue
L3	brown				

## Curves: Air performance 60 Hz

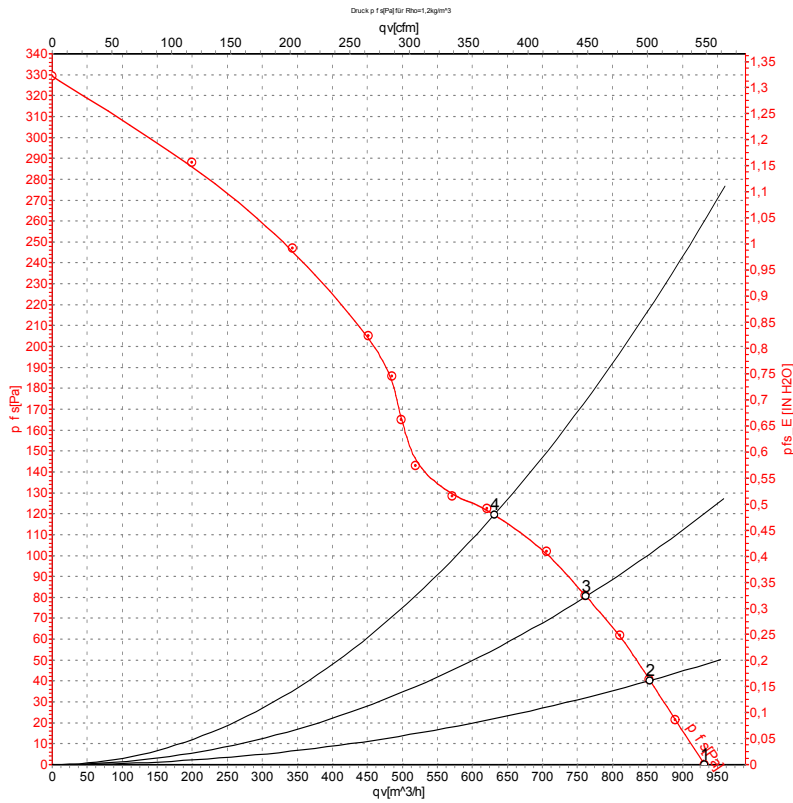

Measurement: LU-20134-1

Air performance measured according to ISO 5801 installation category A. For detailed information on the measurement setup, contact ebmpapst. Intake sound level: Sound power level according to ISO 13347 / sound pressure level measured at 1 m distance from fan axis. The values given are valid under the specified measuring conditions and may vary due to conditions of installation. For deviations from the standard configuration, the parameters have to be checked on the installed unit.

## Measured values

	U	f	n	P <sub>e</sub>	I	q <sub>V</sub>	P <sub>fs</sub>	q <sub>V</sub>	P <sub>fs</sub>
	V	Hz	min <sup>-1</sup>	W	A	m <sup>3</sup> /h	Pa	cfm	in. wg
1	400	60	3100	81	0.15	930	0	550	0.00
2	400	60	3070	85	0.15	855	40	505	0.16
3	400	60	3040	88	0.15	760	80	450	0.32
4	400	60	3030	89	0.15	630	120	370	0.48

U = Voltage · f = Frequency · n = Speed (rpm) · P<sub>e</sub> = Power consumption · I = Current draw · q<sub>V</sub> = Air flow · p<sub>fs</sub> = Pressure increase

