

A1G300-AB19-10 ebmpapst Datasheet

sales@fansco.com

www.fansco.com

Limited partnership · Headquarters Mulfingen

Amtsgericht (court of registration) Stuttgart · HRA 590344

General partner Elektrobau Mulfingen GmbH · Headquarters Mulfingen

Amtsgericht (court of registration) Stuttgart · HRB 590142

Nominal data

Type	A1G300-AB19-10		
Motor	M1G055-BI		
Phase		1~	1~
Nominal voltage	VAC	230	230
Frequency	Hz	50/60	50/60
Method of obtaining data		ml	ml
Speed (rpm)	min ⁻¹	1300	900
Power consumption	W	35	
Current draw	A	0.27	-
Min. ambient temperature	°C	-30	-30
Max. ambient temperature	°C	50	50

ml = Max. load · me = Max. efficiency · fa = Free air · cs = Customer specification · ce = Customer equipment
Subject to change



Technical description

Weight	1.2 kg
Fan size	300 mm
Electronics housing material	Die-cast aluminum
Blade material	PA plastic
Number of blades	5
Airflow direction	"V"
Direction of rotation	Counterclockwise, viewed toward rotor
Degree of protection	IP54
Insulation class	"B"
Moisture (F) / Environmental (H) protection class	H1
Max. permitted ambient temp. for motor (transport/storage)	+ 80 °C
Min. permitted ambient temp. for motor (transport/storage)	- 40 °C
Installation position	Any
Condensation drainage holes	None
Mode	S1
Motor bearing	Ball bearing with low-temperature lubricant
Technical features	<ul style="list-style-type: none"> - Speed setting input (230 V) - Soft start - Thermal overload protection for motor
Speed levels	2
EMC immunity to interference	According to EN 61000-6-2 (industrial environment)
EMC circuit feedback	According to EN 61000-3-2/3
EMC interference emission	According to EN 61000-6-3 (household environment)
Electrical hookup	With plug
Motor protection	Thermal overload protector (TOP) internally connected
With cable	Lateral
Protection class	II
Conformity with standards	EN 60335-1; EN 60335-2-24; EN 60335-2-80; EN 60335-2-89; CE
Approval	VDE; CSA C22.2 No. 77; UL 1004-3; CCC

EC axial fan

sickle-shaped blades (S series), single-intake

Product drawing

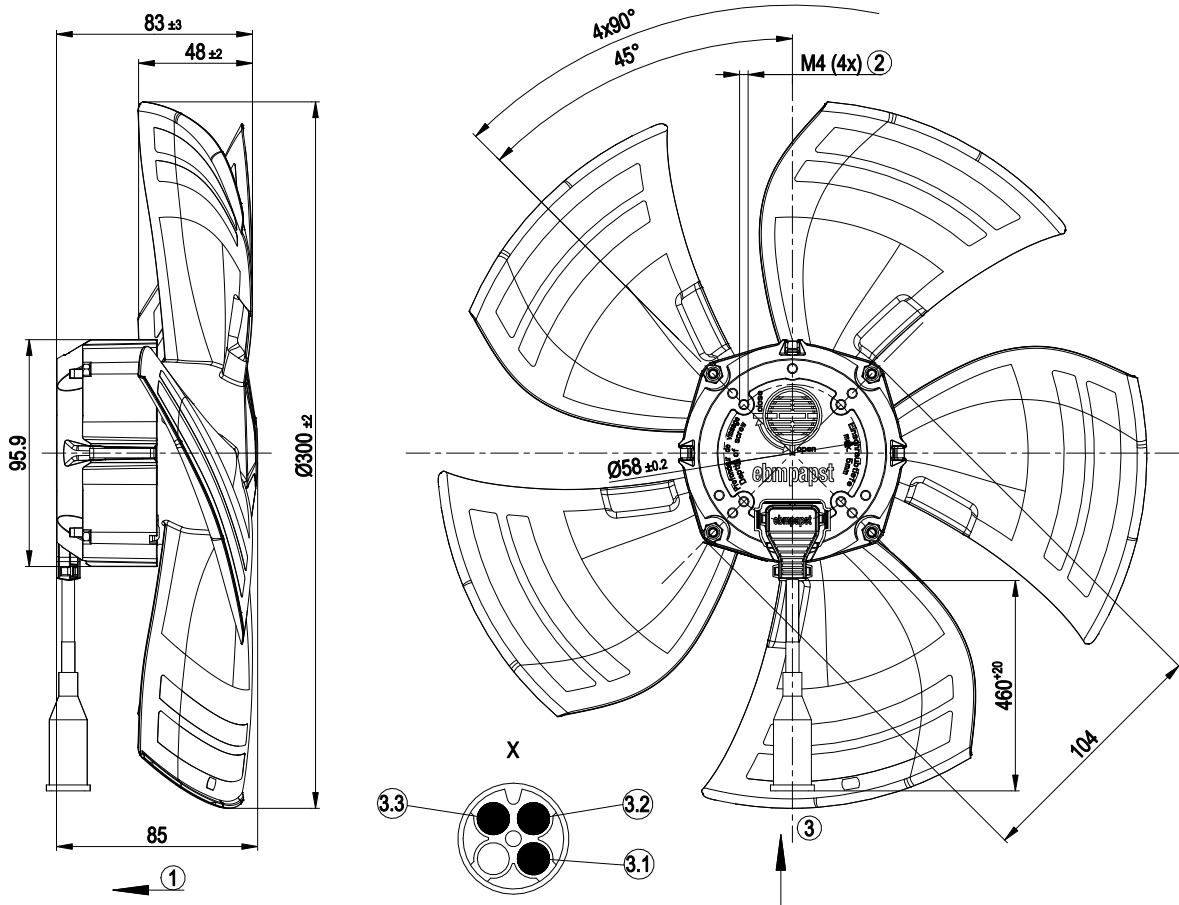

1	Direction of air flow "V"
2	Max. clearance for screw 5 mm
3	Cable PVC 3G AWG20 with connector housing TE Connectivity no. 0-925075-3 and insulating sleeve
3.1	blue (N)
3.2	black (L)
3.3	brown (speed selection)



Connection diagram

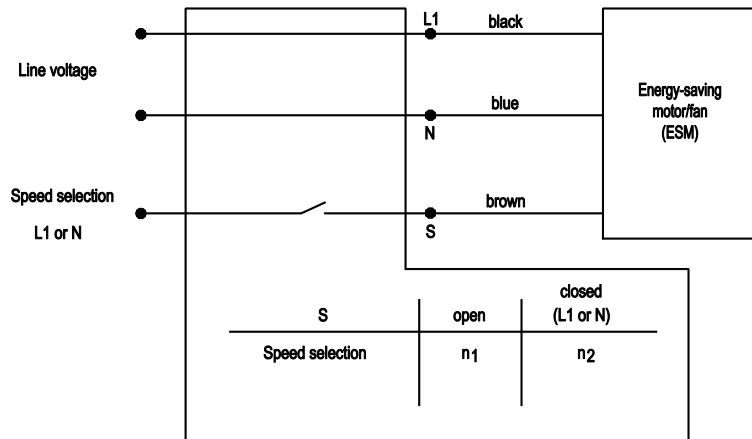

Curves: Air performance 50 Hz

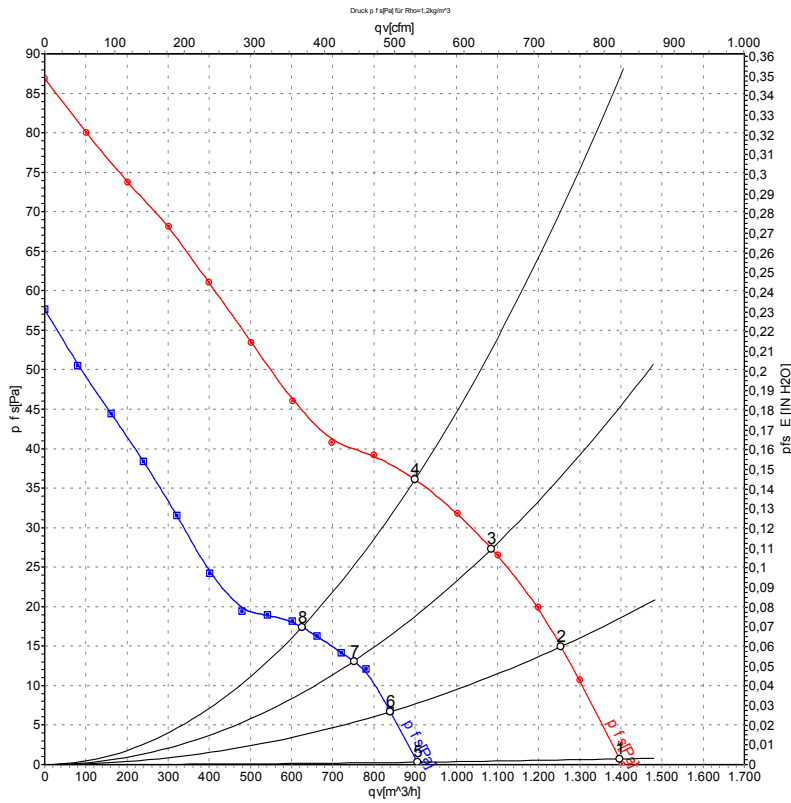

Measurement: LU-110298-1
Measurement: LU-110308-1

Air performance measured according to ISO 5801 installation category A. For detailed information on the measurement setup, contact ebm-papst. Intake sound level: Sound power level according to ISO 13347 / sound pressure level measured at 1 m distance from fan axis. The values given are valid under the specified measuring conditions and may vary due to conditions of installation. For deviations from the standard configuration, the parameters have to be checked on the installed unit.

Measured values

	U	f	n	P _{ed}	I	LpA _{in}	LwA _{in}	η _{esd}	q _v	P _{fs}	q _v	P _{fs}
	V	Hz	min ⁻¹	W	A	dB(A)	dB(A)	%	m ³ /h	Pa	cfm	inH ₂ O
1	230	50	1300	32	0.25	52	58	24	1395	0	820	0.00
2	230	50	1300	34	0.27	52	58	31	1255	15	740	0.06
3	230	50	1300	34	0.27	51	57	33	1085	28	640	0.11
4	230	50	1300	35	0.27	52	58	30	900	35	530	0.14
5	230	50	900	13	0.12	43	50	17	905	0	535	0.00
6	230	50	900	14	0.13	42	49	23	840	7	495	0.03
7	230	50	900	15	0.14	42	49	26	750	13	445	0.05
8	230	50	900	16	0.15	43	50	23	625	17	370	0.07

U = Power supply · f = Frequency · n = Speed (rpm) · P_{ed} = Power consumption · I = Current draw · LpA_{in} = Sound pressure level intake side · LwA_{in} = Sound power level intake side
η_{esd} = Total efficiency of fan · q_v = Air flow · p_{fs} = Pressure increase

