

A1G280-AA79-11

EC axial fan

sickled blades (S series)

Automotive



A1G280-AA79-11 ebmpapst Datasheet

sales@fansco.com

www.fansco.com

Nominal data

Type	A1G280-AA79-11	
Motor	M1G074-BF	
Nominal voltage	[VDC]	13,2
Nominal voltage range	[VDC]	8 .. 16
Type of data definition		rfa
Speed	[min ⁻¹]	2350
Power input	[W]	90
Current draw	[A]	7,3
Max. ambient temperature	[°C]	60
Air flow	[m ³ /h]	1810
Back pressure	[Pa]	0
Sound pressure level	[dB(A)]	63

ml = max. load · me = max. efficiency · rfa = running at free air · cs = customer specs · cu = customer unit
Subject to alterations

EC axial fan

sickled blades (S series)

Automotive

Technical features

Leakage current	<= 0,25 mA
Size	280 mm
Operation mode	S1
Direction of rotation	Clockwise, seen on rotor
Mounting position	Shaft horizontal or rotor on bottom
Insulation class	"B"
Cable exit	Variable
Bearing motor	Ball bearing
Mass	1.6 kg
Material of impeller	PA/SPS plastic, color: black (in accordance with UL 94 HB)
Motor protection	Reverse polarity and locked-rotor protection
Number of blades	5
Type of protection	IP 44 - depending on position
Technical features	0-10 VDC / PWM control input, tach output

A1G280-AA79-11

EC axial fan

sickled blades (S series)

Automotive

Product drawing

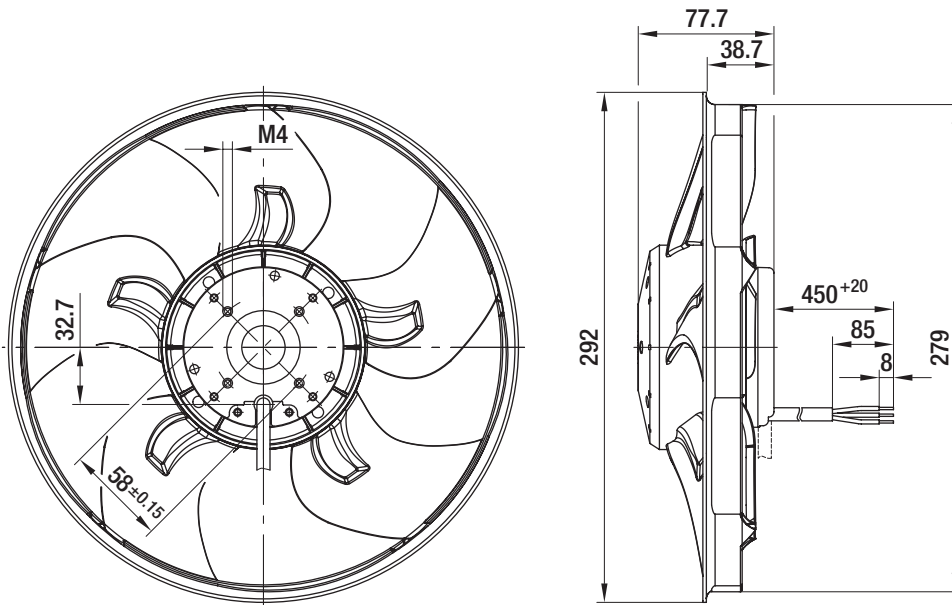

Connection screen

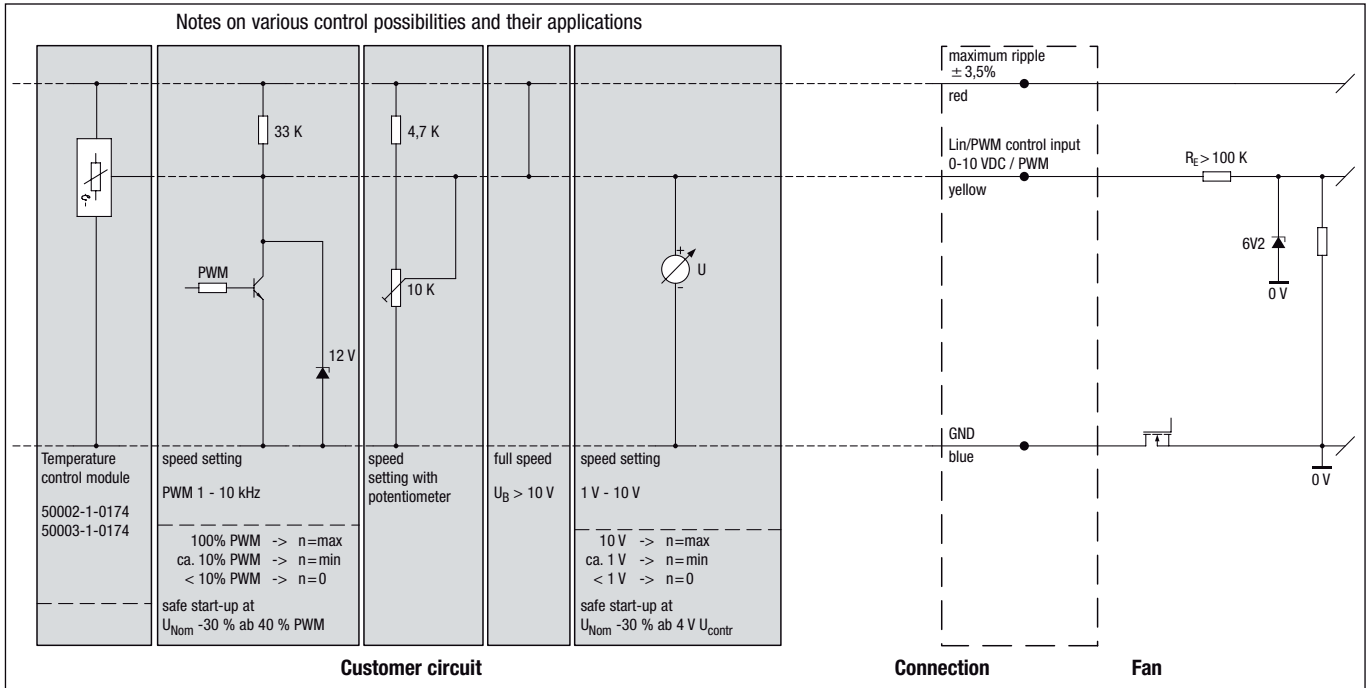

Charts: Air flow

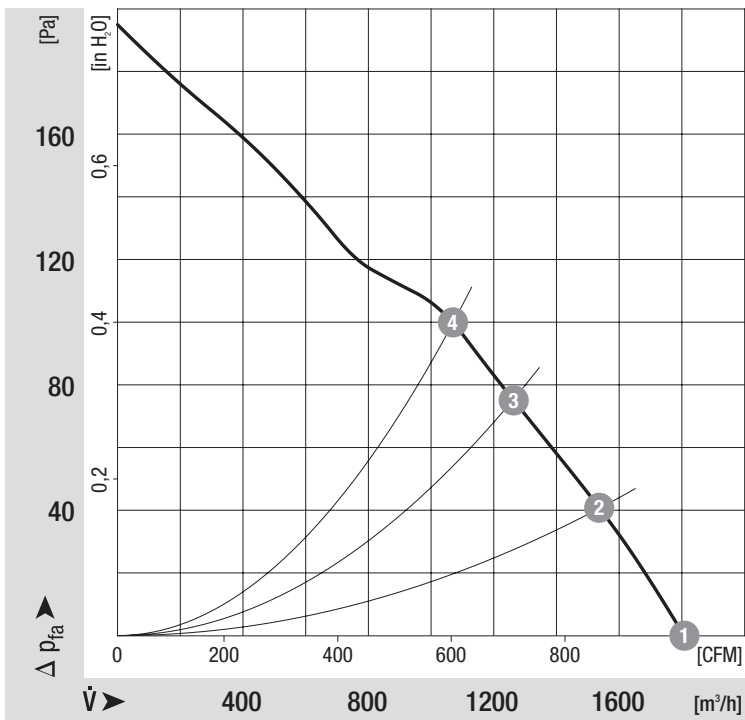

Measured values

	n	P ₁	η _{Ges}
	[min ⁻¹]	[W]	[%]
1	2350	90	31
2	2330	89	38
3	2360	88	39
4	2340	90	38