

A1G250-AI37-52 ebmpapst Datasheet

sales@fansco.com

www.fansco.com

Nominal data

Type	A1G250-AI37-52	
Motor	M1G074-BF	
Nominal voltage	VDC	24
Nominal voltage range	VDC	16 .. 28
Method of obtaining data		fa
Speed (rpm)	min ⁻¹	2750
Power consumption	W	105
Current draw	A	5.0
Max. back pressure	Pa	140
Max. back pressure	in. wg	0.56
Min. ambient temperature	°C	-25
Max. ambient temperature	°C	60

ml = Max. load · me = Max. efficiency · fa = Free air · cs = Customer specification · ce = Customer equipment
Subject to change



Technical description

Weight	1.5 kg
Size	250 mm
Motor size	74
Rotor surface	Painted black
Impeller material	Sheet steel, painted black
Number of blades	9
Airflow direction	A
Direction of rotation	Counterclockwise, viewed toward rotor
Degree of protection	IP42
Insulation class	"B"
Moisture (F) / Environmental (H) protection class	H0 - dry environment
Max. permitted ambient temp. for motor (transport/storage)	+80 °C
Min. permitted ambient temp. for motor (transport/storage)	-40 °C
Installation position	Any
Condensation drainage holes	None
Mode	S1
Motor bearing	Ball bearing
Technical features	<ul style="list-style-type: none"> - Tach output - Motor current limitation - Soft start - Control input 0-10 VDC / PWM
EMC immunity to interference	According to EN 61000-6-2 (industrial environment)
EMC interference emission	According to EN 55022 (Class B, household environment)
Motor protection	Reverse polarity and locked-rotor protection
With cable	Variable
Protection class assignment	<p>III; Requires supply with safety extra-low voltage SELV.</p> <p>This component for installation may have several local protection classes. This information relates to this component's basic design.</p> <p>The final protection class is based on the component's intended installation and connection.</p>
Conformity with standards	EN 62368-1
Approval	CSA C22.2 No. 77; EAC; UL 1004-1

Product drawing

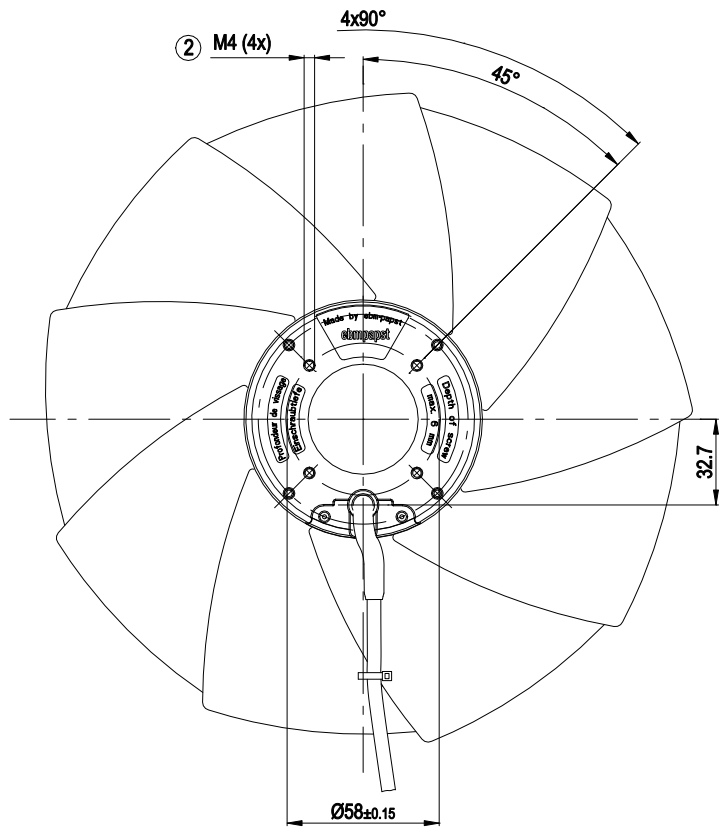
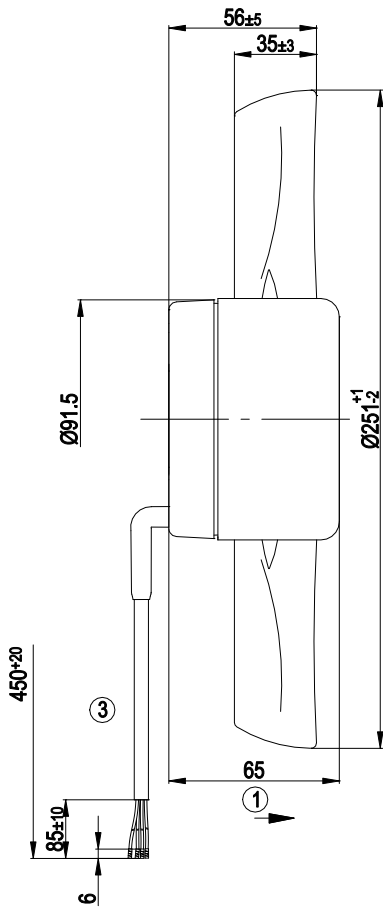

1	Direction of air flow "A"
2	Max. clearance for screw 6 mm
3	Cable PVC AWG20, 4x crimped splices



Connection diagram

Customer circuit

Full speed

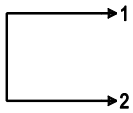

Adjustable speed

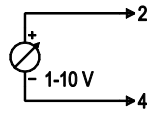

10 V → n = max
1 V → n = min
< 1 V → n = 0
Safe start at Unom -30% from 4 V Ucontr.

Speed adjustable via potentiometer

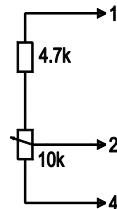

Speed adjustable via PWM 1-10 kHz

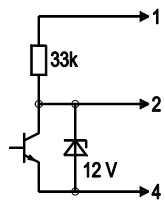

100% PWM → n = max
10% PWM → n = min
< 10% PWM → n = 0
Safe start at Unom -30% from 40% PWM

Set value requirement via temperature controller

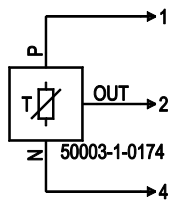

T < 10 °C → n = 0
T > 45 °C → n = max

Connection

Fan / Motor

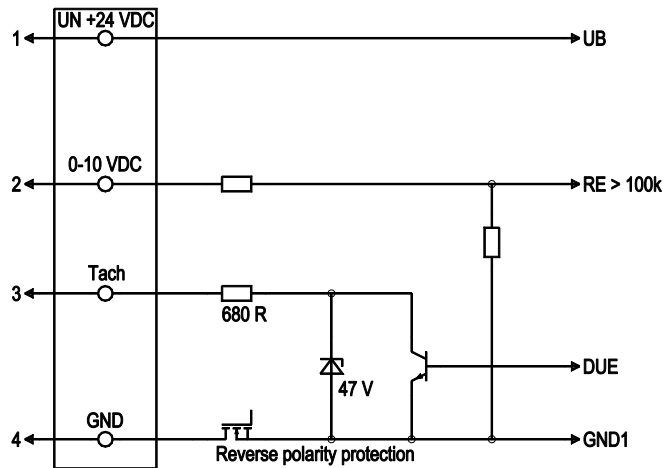

No.	Conn.	Designation	Color	Function/assignment
1	1	Un +24 VDC	red	Power supply 24 VDC, maximum ripple 3.5 %
1	2	0-10 VDC	yellow	Control input Re > 100k
1	3	Tach	white	Tach output, 3 pulses per revolution, Isink max = 10 mA
1	4	GND	blue	Reference ground



Curves: Air performance

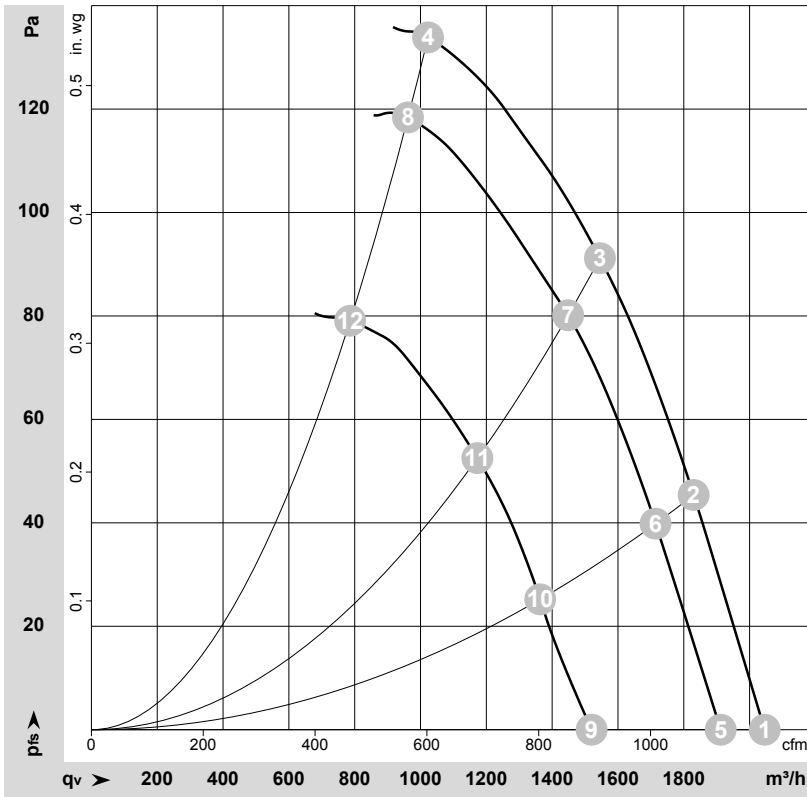

$\rho = 1.15 \text{ kg/m}^3 \pm 2 \%$

Measurement: LU-54187-1
 Measurement: LU-54186-1
 Measurement: LU-54185-1

Air performance measured according to ISO 5801 installation category A. For detailed information on the measurement setup, contact ebm-papst. Intake sound level: Sound power level according to ISO 13347 / sound pressure level measured at 1 m distance from fan axis. The values given are valid under the specified measuring conditions and may vary due to conditions of installation. For deviations from the standard configuration, the parameters have to be checked on the installed unit.

Measured values

	U	n	P _{ed}	I	q _v	p _{fs}	q _v	p _{fs}
	V	min ⁻¹	W	A	m ³ /h	Pa	cfm	in. wg
1	28	2905	125	5.31	2045	0	1205	0.00
2	28	2780	128	5.52	1830	46	1075	0.18
3	28	2650	131	5.78	1545	91	910	0.37
4	28	2585	134	5.92	1025	135	600	0.54
5	24	2750	105	5.00	1910	0	1125	0.00
6	24	2610	106	5.12	1715	40	1010	0.16
7	24	2500	108	5.31	1450	80	855	0.32
8	24	2435	110	5.44	960	120	565	0.48
9	16	2180	53	3.74	1520	0	895	0.00
10	16	2115	56	3.92	1365	25	805	0.10
11	16	2040	59	4.13	1175	53	690	0.21
12	16	2000	61	4.26	785	79	465	0.32

U = Voltage · n = Speed (rpm) · P_{ed} = Power consumption · I = Current draw · q_v = Air flow · p_{fs} = Pressure increase

