

8317083519  
VMA0500HTRHZ

# EC axial fan - HyBlade

sickle-shaped blades (S series)  
with guard grille for short nozzle

8317083519 ebmpapst Datasheet FansCo

sales@fansco.com  
www.fansco.com

## Nominal data

Type	8317083519	
Motor	M3G112-EA	
Phase		3~
Nominal voltage	VAC	400
Nominal voltage range	VAC	380 .. 480
Frequency	Hz	50/60
Method of obtaining data		me
Speed (rpm)	min <sup>-1</sup>	1500
Power consumption	W	860
Current draw	A	1.6
Min. ambient temperature	°C	-25
Max. ambient temperature	°C	60

ml = Max. load · me = Max. efficiency · fa = Free air · cs = Customer specification · ce = Customer equipment  
Subject to change

## Data according to Commission Regulation (EU) 327/2011 (EN 17166)

		Actual	Req. 2015			
01 Overall efficiency $\eta_{es}$	%	45.5	33.3	09 Power consumption $P_{ed}$	kW	0.87
02 Measurement category		A		09 Air flow $q_v$	m <sup>3</sup> /h	6103
03 Efficiency category		Static		09 Pressure increase $p_{fs}$	Pa	215
04 Efficiency grade N		52.2	40	10 Speed (rpm) n	min <sup>-1</sup>	1500
05 Variable speed drive		Yes		11 Specific ratio*		1.00

Data obtained at optimum efficiency level.  
The ErP data is determined using a motor-impeller combination in a standardized measurement setup.

\* Specific ratio =  $1 + p_g / 100\,000\text{ Pa}$

LU-15834



8317083519  
VMA0500HTRHZ

# EC axial fan - HyBlade

sickle-shaped blades (S series)  
with guard grille for short nozzle

## Technical description

<b>Weight</b>	11 kg
<b>Size</b>	500 mm
<b>Motor size</b>	112
<b>Rotor surface</b>	Painted black
<b>Electronics housing material</b>	Die-cast aluminum
<b>Blade material</b>	Press-fitted sheet steel blank, sprayed with PP plastic
<b>Guard grille material</b>	Steel, coated with black plastic (RAL 9005)
<b>Number of blades</b>	5
<b>Airflow direction</b>	V
<b>Direction of rotation</b>	Counterclockwise, viewed toward rotor
<b>Degree of protection</b>	IP54
<b>Insulation class</b>	"B"
<b>Moisture (F) / Environmental (H) protection class</b>	H1
<b>Max. permitted ambient temp. for motor (transport/storage)</b>	+80 °C
<b>Min. permitted ambient temp. for motor (transport/storage)</b>	-40 °C
<b>Installation position</b>	Shaft horizontal or rotor on bottom; rotor on top on request
<b>Condensation drainage holes</b>	On rotor side
<b>Mode</b>	S1
<b>Motor bearing</b>	Ball bearing
<b>Technical features</b>	<ul style="list-style-type: none"><li>- Output 10 VDC, max. 10 mA</li><li>- Output 20 VDC, max. 50 mA</li><li>- Output for slave 0-10 V</li><li>- Input for sensor 0-10 V or 4-20 mA</li><li>- External 24 V input (parameter setting)</li><li>- Alarm relay</li><li>- Integrated PID controller</li><li>- Motor current limitation</li><li>- PFC, passive</li><li>- RS-485 MODBUS-RTU</li><li>- Soft start</li><li>- Control input 0-10 VDC / PWM</li><li>- Control interface with SELV potential safely disconnected from supply</li><li>- Thermal overload protection for electronics/motor</li><li>- Line undervoltage / phase failure detection</li></ul>
<b>EMC immunity to interference</b>	According to EN 61000-6-2 (industrial environment)
<b>EMC circuit feedback</b>	According to EN 61000-3-2/3
<b>EMC interference emission</b>	According to EN 61000-6-3 (household environment)
<b>Touch current according to IEC 60990 (measuring circuit Fig. 4, TN system)</b>	<= 3.5 mA
<b>Electrical hookup</b>	Terminal box
<b>Motor protection</b>	Thermal overload protector (TOP) internally connected
<b>With cable</b>	Variable
<b>Protection class</b>	I (with customer connection of protective earth)
<b>Conformity with standards</b>	CCC
<b>Approval</b>	EAC; UL 1004-7 + 60730-1



8317083519  
VMA0500HTRHZ

# EC axial fan - HyBlade

sickle-shaped blades (S series)  
with guard grille for short nozzle

## Product drawing

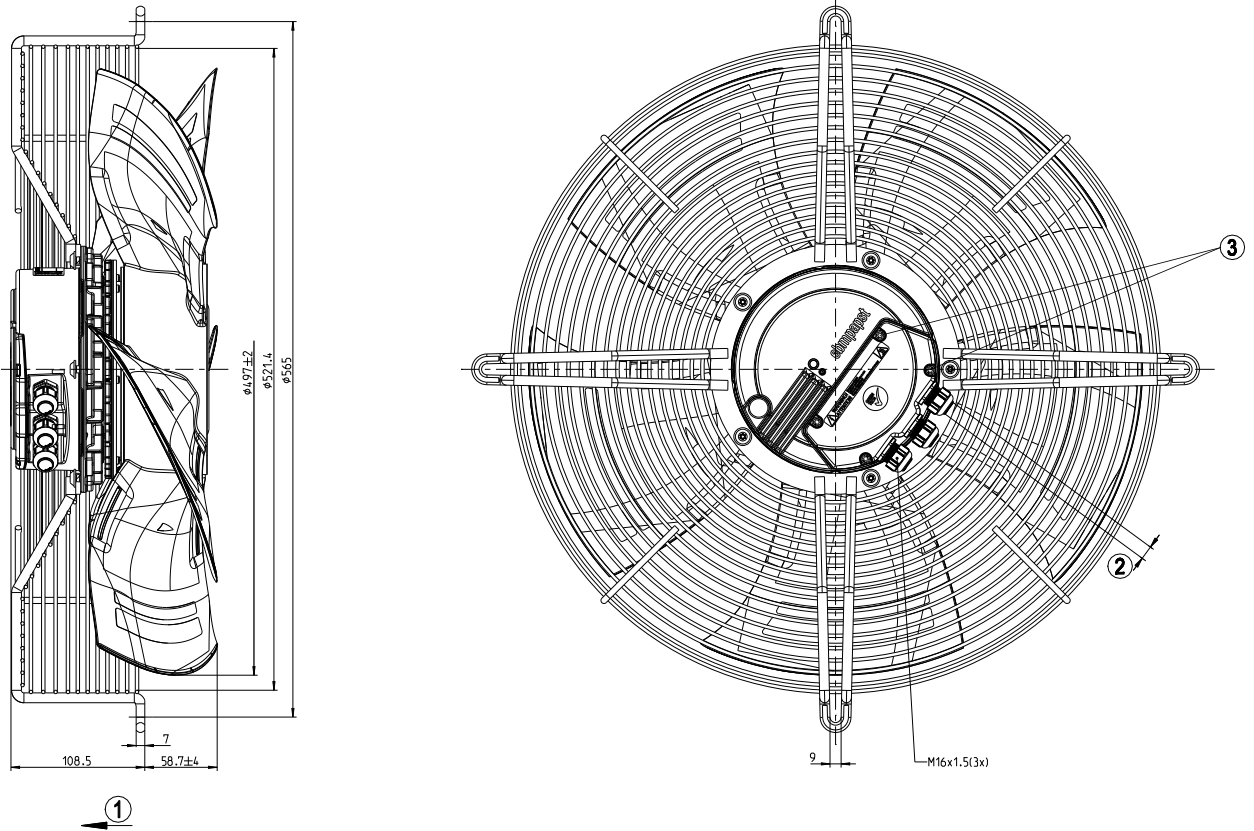

1	Direction of air flow "V"
2	Cable diameter min. 4 mm, max. 10 mm; tightening torque $4 \pm 0.6$ Nm
3	Tightening torque $3.5 \pm 0.5$ Nm

# EC axial fan - HyBlade

sickle-shaped blades(S series)  
with guard grille for short nozzle

## Connection diagram

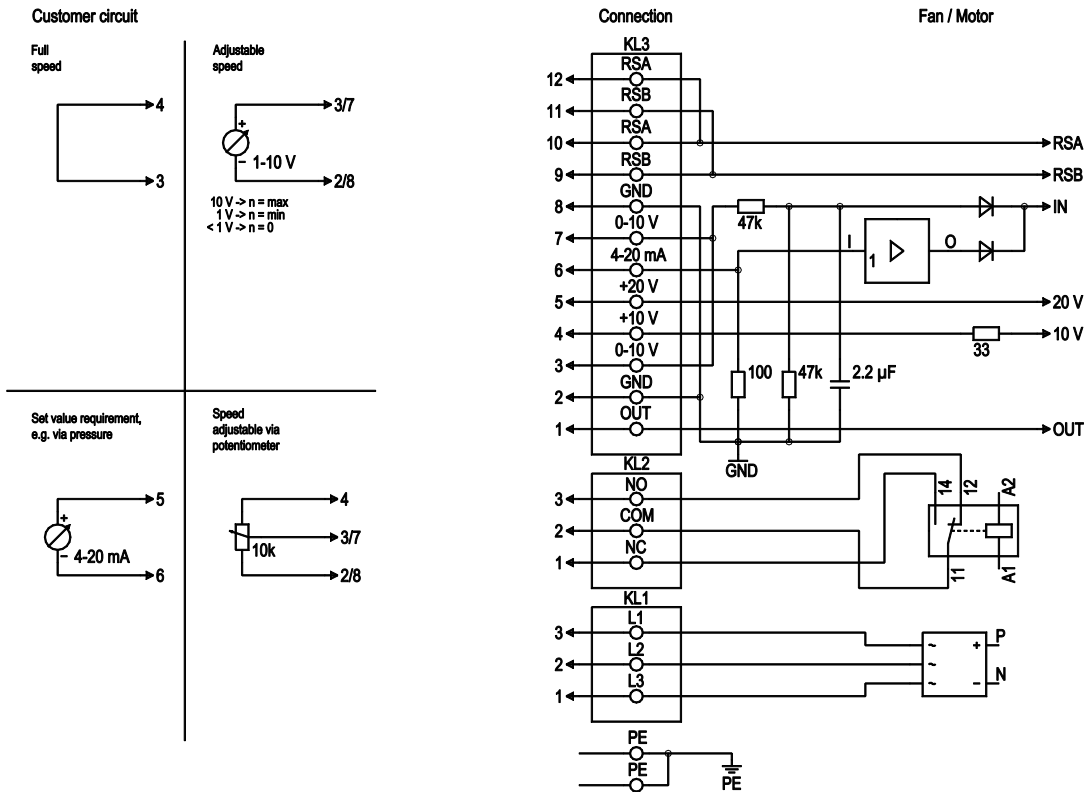

No.	Conn.	Designation	Function/assignment
PE		PE	Protective earth terminal
KL1	1, 2, 3	L1, L2, L3	Power supply, voltage range (see nameplate), 50/60 Hz
KL2	1	NC	Floating status contact, break for failure
KL2	2	COM	floating status contact, changeover contact, common connection (2 A, max. 250 VAC, min. 10 mA, AC1)
KL2	3	NO	Floating status contact, make for failure
KL3	1	OUT	Analog output, 0-10 VDC, max. 3 mA, SELV, output of current motor modulation level: 1 V corresponds to 10% modulation level. 10 V corresponds to 100% modulation level.
KL3	2, 8	GND	Reference ground for control interface, SELV
KL3	3, 7	0-10 V	Use control / current sensor value input 0-10 VDC, impedance 100 kΩ only as alternative to 4-20 mA input, SELV
KL3	4	+10 V	Voltage output 10 VDC (±3%), max. 10 mA, power supply for external devices (e.g. potentiometer), SELV
KL3	5	+20 V	Voltage output 20 VDC (+25%/-10%), max. 50 mA, power supply for external devices (e.g. sensors), SELV
KL3	6	4-20 mA	Use control / current sensor value input 4-20 mA, impedance 100 Ω only as alternative to 0-10 V input, SELV
KL3	9, 11	RSB	RS485 interface for MODBUS, RSB
KL3	10, 12	RSA	RS485 interface for MODBUS, RSA

# EC axial fan - HyBlade

sickle-shaped blades (S series)  
with guard grille for short nozzle

## Curves: Air performance 50 Hz

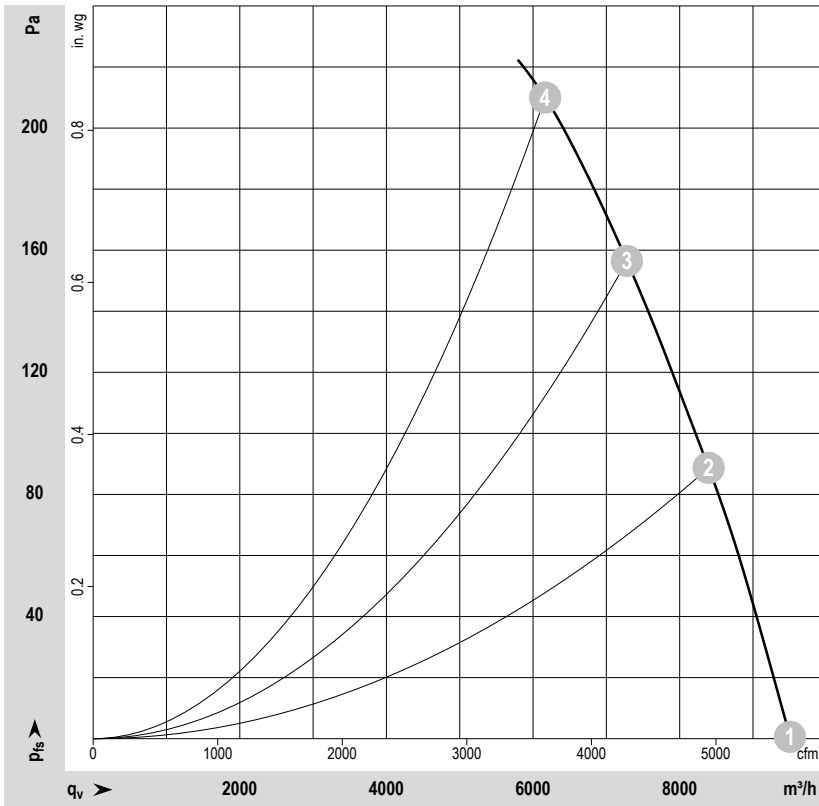

$\rho = 1.2 \text{ kg/m}^3 \pm 2 \%$

Measurement: LU-15834

Air performance measured according to ISO 5801 installation category A. For detailed information on the measurement setup, contact ebm-papst. Intake sound level: Sound power level according to ISO 13347 / sound pressure level measured at 1 m distance from fan axis. The values given are valid under the specified measuring conditions and may vary due to conditions of installation. For deviations from the standard configuration, the parameters have to be checked on the installed unit.

## Fan performance

	Wired	U	f	n	P <sub>ed</sub>	I	q <sub>v</sub>	P <sub>fs</sub>	q <sub>v</sub>	P <sub>fs</sub>
		V	Hz	min <sup>-1</sup>	W	A	m <sup>3</sup> /h	Pa	cfm	in. wg
1	1~	400	50	1500	629	1.22	9505	0	5594	0.00
2	1~	400	50	1500	736	1.37	8395	89	4941	0.35
3	1~	400	50	1500	815	1.51	7280	157	4284	0.63
4	1~	400	50	1500	860	1.60	6165	210	3628	0.84

Wired = Wiring · U = Voltage · f = Frequency · n = Speed (rpm) · P<sub>ed</sub> = Power consumption · I = Current draw

q<sub>v</sub> = Air flow · P<sub>fs</sub> = Pressure increase

