

8317082558
VBS0225RSLFS

EC centrifugal fan

backward-curved, single-intake

8317082558 ebmpapst Datasheet
sales@fansco.com
www.fansco.com

Nominal data

Type	8317082558	
Motor	E06005-30(M3G060-DA)	
Phase		1~
Nominal voltage	VAC	230
Nominal voltage range	VAC	200 .. 240
Frequency	Hz	50/60
Type of data definition		ml
Speed (rpm)	min ⁻¹	2800
Power input	W	170
Current draw	A	1.3
Min. ambient temperature	°C	-25
Max. ambient temperature	°C	60

ml = Max. load · me = Max. efficiency · fa = Running at free air · cs = Customer specs · cu = Customer unit
Subject to alterations

Data according to ErP directive

		Actual	Request 2020
01 Overall efficiency η_{es}	%	54.8	45.4
02 Measurement category		A	
03 Efficiency category		Static	
04 Efficiency grade N		73.4	64
05 Variable speed drive		Yes	

Data definition with optimum efficiency.
The ErP data is determined using a motor-impeller combination in a standardised measurement configuration.

09 Power input P_{ed}	kW	0.17
09 Air flow q_v	m ³ /h	724
09 Pressure increase p_{fs}	Pa	405
10 Speed (rpm) n	min ⁻¹	2850
11 Specific ratio [*]		1.00

^{*} Specific ratio = $1 + p_{fs} / 100\,000\text{ Pa}$

ID14744



8317082558
VBS0225RSLFS

EC centrifugal fan

backward-curved, single-intake

Technical description

Weight	1.75 kg
Size	225 mm
Motor size	60
Rotor surface	Thick-film passivated
Electronics housing material	Die-cast aluminum
Impeller material	Plastic
Number of blades	7
Balancing grade according to DIN ISO 1940-1	G 6.3
Direction of rotation	Clockwise, viewed toward rotor
Degree of protection	IP54
Insulation class	"B"
Moisture (F) / Environmental (H) protection class	H1
Max. permitted ambient temp. for motor (transport/storage)	+ 80 °C
Min. permitted ambient temp. for motor (transport/storage)	- 40 °C
Installation position	Any
Condensation drainage holes	None
Cooling hole/opening	On rotor side
Mode	S1
Motor mounting	Ball bearing
Technical features	<ul style="list-style-type: none">- Output 10VDC, max. 10 mA- Tach output- Power limiter- Motor current limitation- Soft start- Control input 0-10 VDC / PWM- Control interface with SELV potential safely disconnected from the mains- Overvoltage protection- Thermal overload protection for electronics / motor- Line undervoltage detection
EMC immunity to interference	According to EN 61000-6-2(industrial environment)
EMC interference emission	According to EN 61000-6-3(household environment)
Touch current acc.IEC 60990	<=3.5 mA
Motor protection	Reverse polarity and locked-rotor protection
Cable exit	Variable
Protection class	I (if protective earth is connected by customer)
Product conforming to standard	GB12350, EN60034-1, EN60335-1
Approval	-



8317082558
VBS0225RSLFS

EC centrifugal fan

backward-curved, single-intake

Product drawing

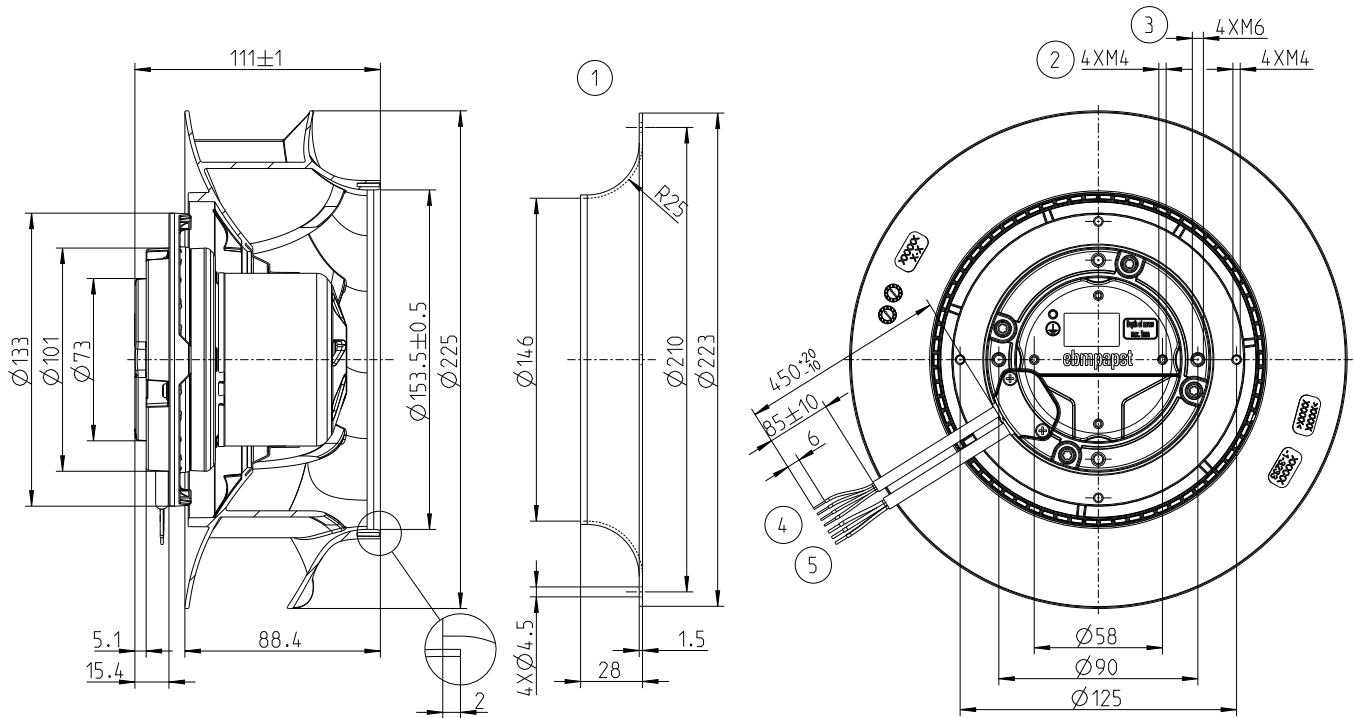

1	Accessory part: inlet ring 96358-2-4013 not included in scope of delivery
2	Max. clearance for screw 6 mm
3	Max. clearance for screw 10 mm
4	Cable PVC 4x0.25 mm ²
5	Cable PVC 3x0.5 mm ²

Connection diagram

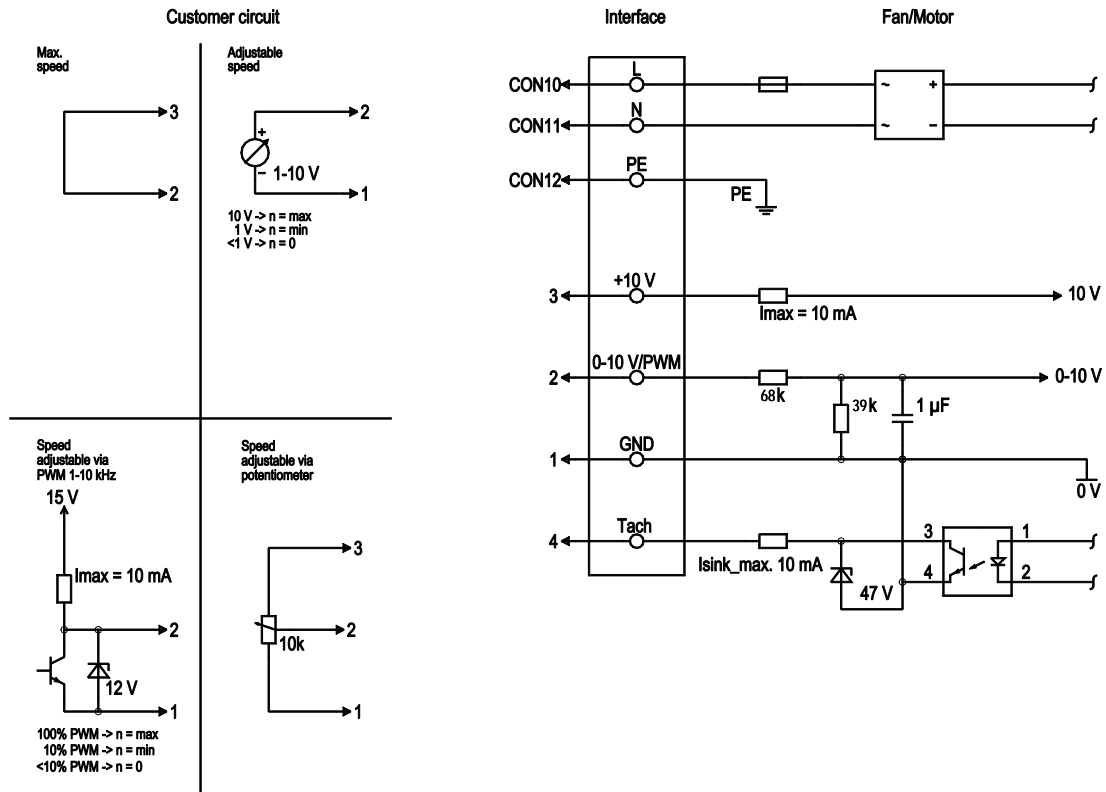

No.	Conn.	Designation	Color	Function/assignment
	CON10	L	black	Supply connection, power supply, phase, see nameplate for voltage range
	CON11	N	blue	Supply connection, power supply, neutral conductor, see nameplate for voltage range
	CON12	PE	green/yellow	Ground connection
	3	+10 V	red	Fixed voltage output 10 VDC ±3 %, I _{max} 10 mA, short-circuit-proof, power supply for ext. devices (e.g. pot), SELV
	2	0-10 V PWM	yellow	0-10 V / PWM control input, R _i =100 kΩ, SELV
	1	GND	blue	Reference ground for control interface, SELV
	4	Tach	white	Tach output, open collector, 1 pulse per revolution, I _{sink max} = 10 mA, SELV

EC centrifugal fan

backward-curved, single-intake

Curves: Air performance

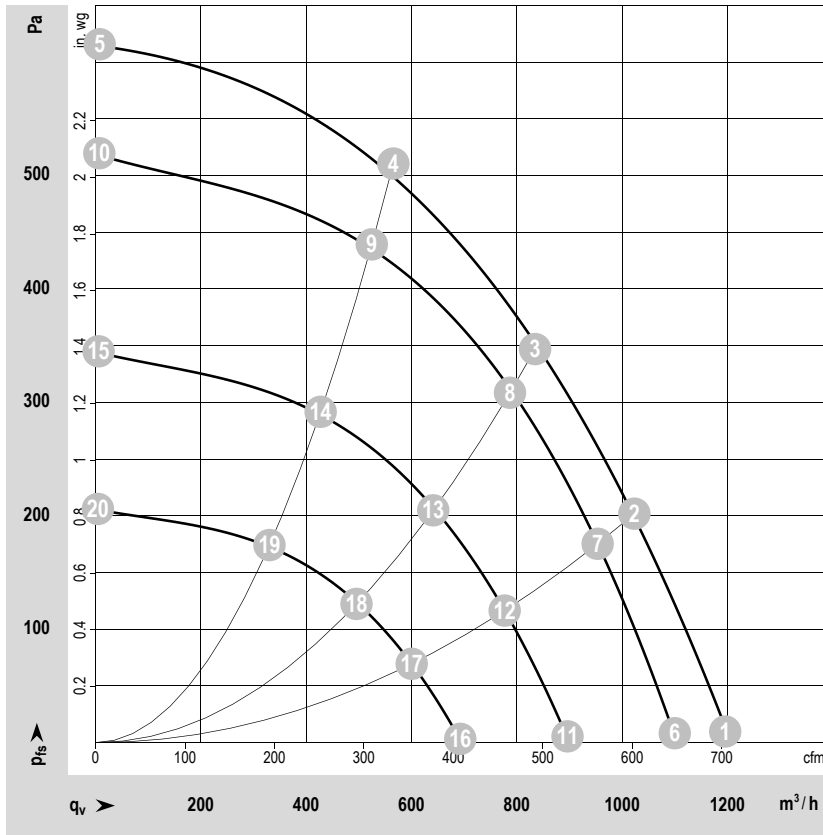

$\rho = 1.2 \text{ kg/m}^3 \pm 2 \%$

Measurement: ID 14744

Air performance measured according to ISO 5801 installation category A. For detailed information on the measurement setup, contact ebm-papst. Intake sound level: Sound power level according to ISO 13347 / sound pressure level measured at 1 m distance from fan axis. The values given are valid under the specified measuring conditions and may vary due to conditions of installation. For deviations from the standard configuration, the parameters have to be checked on the installed unit.

Fan performance

Index	U	f	n	Ped	I	LpAin	LwAin	qv	pfs	qv	Pfs
	v	Hz	min-1	W	A	dB(A)	dB(A)	m3/h	Pa	cfm	in.wg
01	230	50	2935	155.2	1.18	71	79	1196	10	704	0.04
02	230	50	2897	171.6	1.28	67	75	1023	202	602	0.81
03	230	50	2864	171.6	1.27	62	70	835	347	491	1.39
04	230	50	2913	172.0	1.29	63	71	566	513	333	2.06
05	230	50	2939	75.9	0.62			7.8	616	5	2.47
06	230	50	2700	120.8	0.91	69	77	1100	8	647	0.03
07	230	50	2700	139.0	1.03	65	73	954	175	561	0.70
08	230	50	2700	143.8	1.06	61	69	787	308	463	1.24
09	230	50	2700	137.1	1.03	61	69	525	441	309	1.77
10	230	50	2700	58.9	0.48			7.1	520	4	2.09
11	230	50	2200	65.3	0.49	64	72	896	5	527	0.02
12	230	50	2200	75.2	0.56	60	68	777	116	457	0.47
13	230	50	2200	77.8	0.58	56	64	641	205	377	0.82
14	230	50	2200	74.1	0.56	56	64	427	293	251	1.18
15	230	50	2200	31.8	0.26			5.8	345	3	1.39
16	230	50	1700	30.1	0.23	57	65	693	3	408	0.01
17	230	50	1700	34.7	0.26	53	61	600	69	353	0.28
18	230	50	1700	35.9	0.27	49	57	496	122	292	0.49
19	230	50	1700	34.2	0.26	49	58	330	175	194	0.70
20	230	50	1700	14.7	0.12			4.5	206	3	0.83

U = Power supply · n = Speed (rpm) · P_{ed} = Power consumption · I = Current draw · LpA_{in} = Sound pressure level intake side · LwA_{in} = Sound power level intake side · q_v = Air flow
P_{fs} = Pressure increase