

8317082557
VBS0190RSLFS

EC centrifugal fan

backward-curved, single-intake

8317082557 ebmpapst Datasheet
sales@fansco.com
www.fansco.com

Nominal data

Type	8317082557	
Motor	E06005-30(M3G060-DA)	
Phase		1~
Nominal voltage	VAC	230
Nominal voltage range	VAC	200 .. 240
Frequency	Hz	50/60
Type of data definition		ml
Speed (rpm)	min ⁻¹	4000
Power input	W	170
Current draw	A	1.3
Min. ambient temperature	°C	-25
Max. ambient temperature	°C	60

ml = Max. load · me = Max. efficiency · fa = Running at free air · cs = Customer specs · cu = Customer unit
Subject to alterations

Data according to ErP directive

		Actual	Request 2020
01 Overall efficiency η_{es}	%	53.5	45.4
02 Measurement category		A	
03 Efficiency category		Static	
04 Efficiency grade N		72.1	64
05 Variable speed drive		Yes	

Data definition with optimum efficiency.
The ErP data is determined using a motor-impeller combination in a standardised measurement configuration.

09 Power input P_{ed}	kW	0.17
09 Air flow q_v	m ³ /h	533
09 Pressure increase p_{fs}	Pa	534
10 Speed (rpm) n	min ⁻¹	4144
11 Specific ratio [*]		1.01

^{*} Specific ratio = $1 + p_{fs} / 100\,000\text{ Pa}$

ID-14750



Technical description

Weight	1.5 kg
Size	190 mm
Motor size	60
Rotor surface	Thick-film passivated
Electronics housing material	Die-cast aluminum
Impeller material	Plastic
Number of blades	7
Balancing grade according to DIN ISO 1940-1	G 6.3
Direction of rotation	Clockwise, viewed toward rotor
Degree of protection	IP54
Insulation class	"B"
Moisture (F) / Environmental (H) protection class	H1
Max. permitted ambient temp. for motor (transport/storage)	+ 80 °C
Min. permitted ambient temp. for motor (transport/storage)	- 40 °C
Installation position	Any
Condensation drainage holes	None
Cooling hole/opening	On rotor side
Mode	S1
Motor mounting	Ball bearing
Technical features	<ul style="list-style-type: none"> - Output 10VDC, max. 10 mA - Tach output - Power limiter - Motor current limitation - Soft start - Control input 0-10 VDC / PWM - Control interface with SELV potential safely disconnected from the mains - Overvoltage protection - Thermal overload protection for electronics / motor - Line undervoltage detection
EMC immunity to interference	According to EN 61000-6-2(industrial environment)
EMC interference emission	According to EN 61000-6-3(household environment)
Touch current acc.IEC 60990	<=3.5 mA
Motor protection	Reverse polarity and locked-rotor protection
Cable exit	Variable
Protection class	I (if protective earth is connected by customer)
Product conforming to standard	GB12350, EN60034-1, EN60335-1
Approval	-

8317082557
VBS0190RSLFS

Sample

EC centrifugal fan

backward-curved, single-intake

Product drawing

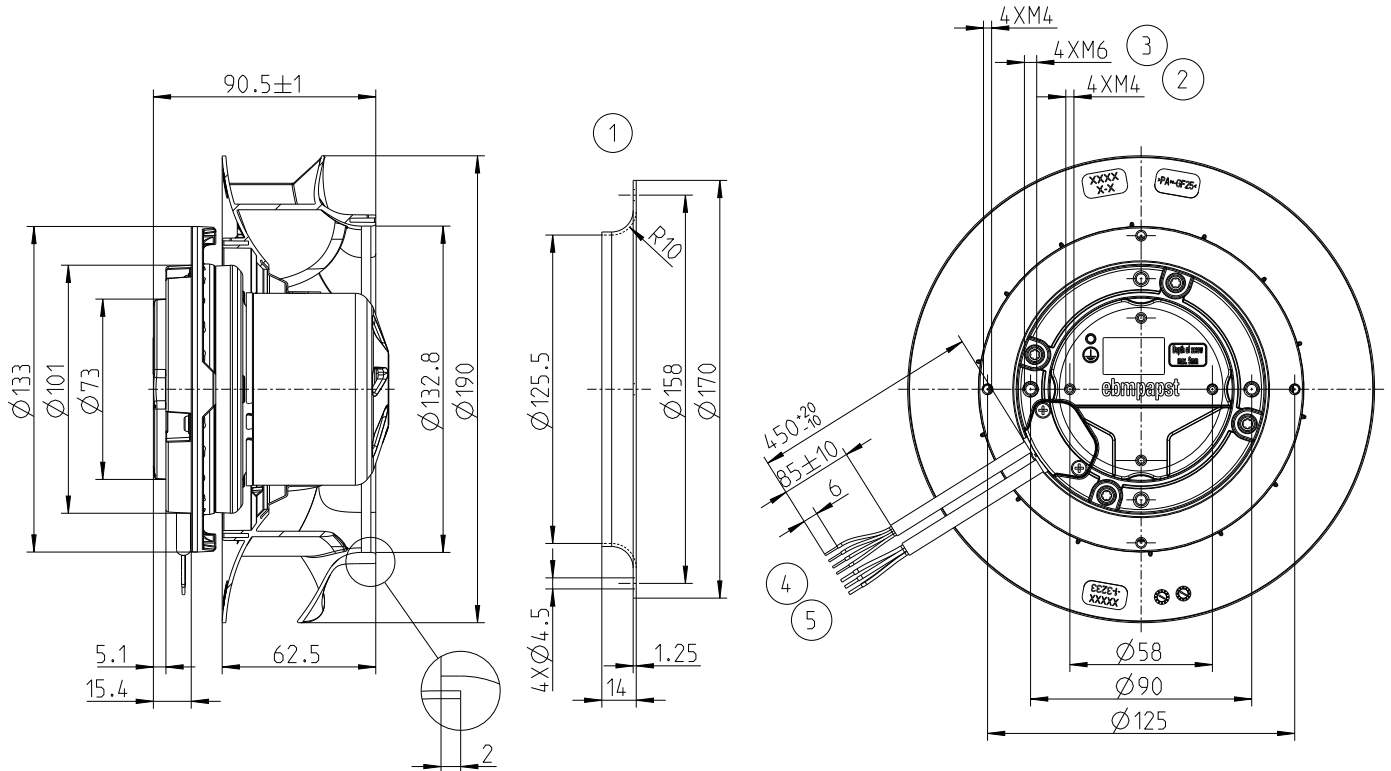

1	Accessory part: inlet ring 09576-2-4013 not included in scope of delivery
2	Max. clearance for screw 6 mm
3	Max. clearance for screw 10 mm
4	Cable PVC 4x0.25 mm ²
5	Cable PVC 3x0.5 mm ²

Connection diagram

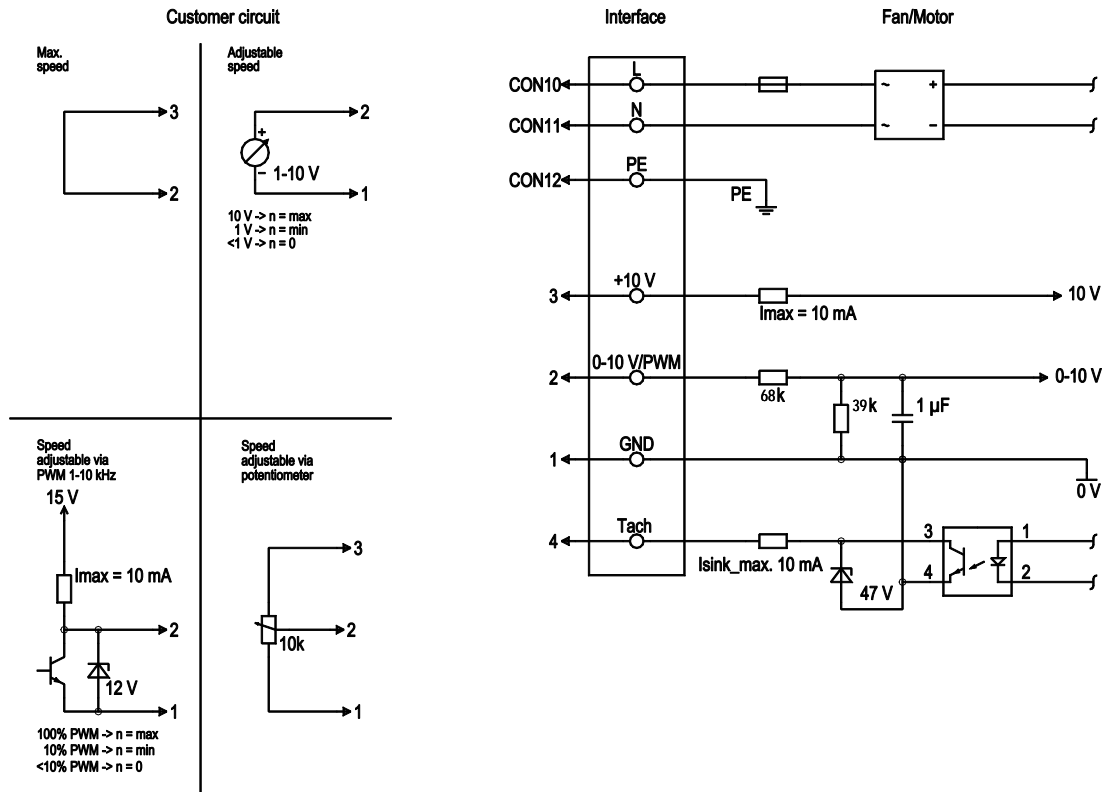

No.	Conn.	Designation	Color	Function/assignment
	CON10	L	black	Supply connection, power supply, phase, see nameplate for voltage range
	CON11	N	blue	Supply connection, power supply, neutral conductor, see nameplate for voltage range
	CON12	PE	green/yellow	Ground connection
	3	+10 V	red	Fixed voltage output 10 VDC +/-3 %, Imax. 10 mA, short-circuit-proof, power supply for ext. devices (e.g. pot), SELV
	2	0-10 V PWM	yellow	0-10 V / PWM control input, Ri=100 kΩ, SELV
	1	GND	blue	Reference ground for control interface, SELV
	4	Tach	white	Tach output, open collector, 1 pulse per revolution, Isink max = 10 mA, SELV

Curves: Air performance

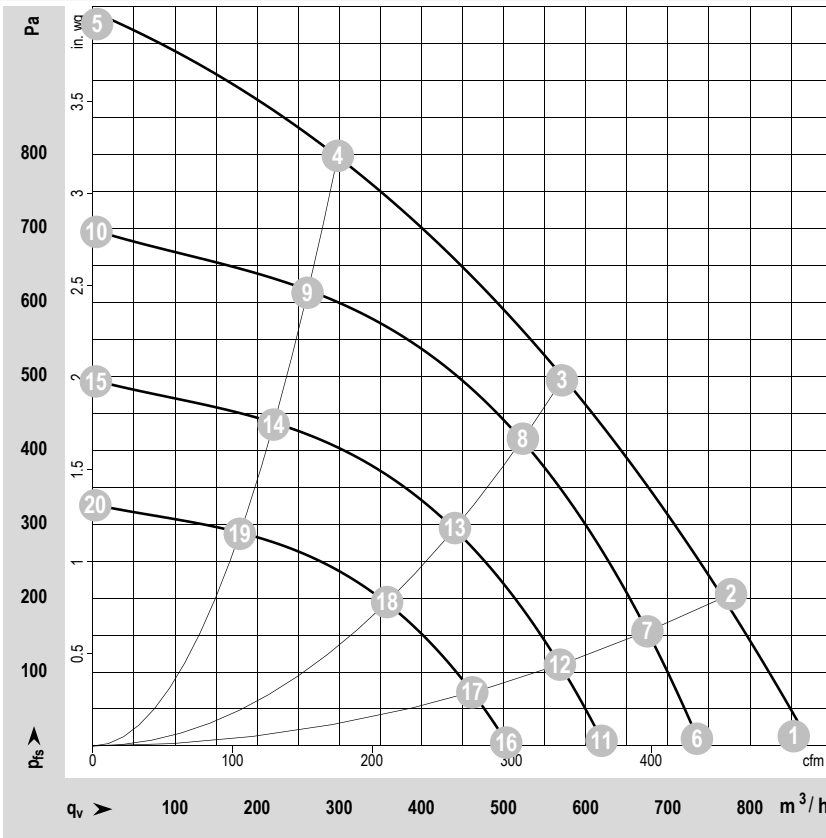

$\rho = 1.2 \text{ kg/m}^3 \pm 2 \%$

Measurement: ID 14750

Air performance measured according to ISO 5801 installation category A. For detailed information on the measurement setup, contact ebm-papst. Intake sound level: Sound power level according to ISO 13347 / sound pressure level measured at 1 m distance from fan axis. The values given are valid under the specified measuring conditions and may vary due to conditions of installation. For deviations from the standard configuration, the parameters have to be checked on the installed unit.

Fan performance

Index	U V	f Hz	n min ⁻¹	P _{ed} W	I A	LpA _{in} dB(A)	LwA _{in} dB(A)	q _v m ³ /h	p _{fs} Pa	q _v cfm	P _{fs} in.wg
01	230	50	4409	171.1	1.30	75	82	853	13	502	0.05
02	230	50	4373	170.8	1.28	71	79	777	205	457	0.82
03	230	50	4142	171.2	1.31	66	74	571	494	336	1.98
04	230	50	4335	171.0	1.28	73	81	298	799	175	3.21
05	230	50	4503	97.7	0.84			5.1	976	3	3.92
06	230	50	3800	109.5	0.83	71	79	735	10	432	0.04
07	230	50	3800	112.1	0.84	67	75	675	155	397	0.62
08	230	50	3800	132.2	1.01	64	72	523	416	308	1.67
09	230	50	3800	115.2	0.86	70	78	261	614	154	2.46
10	230	50	3800	58.7	0.50			4.3	695	3	2.79
11	230	50	3200	65.4	0.50	67	74	619	7	364	0.03
12	230	50	3200	66.9	0.50	63	71	568	110	334	0.44
13	230	50	3200	78.9	0.60	59	67	441	295	259	1.18
14	230	50	3200	68.8	0.52	66	74	220	435	129	1.75
15	230	50	3200	35.0	0.30			3.6	493	2	1.98
16	230	50	2600	35.1	0.27	61	69	503	5	296	0.02
17	230	50	2600	35.9	0.27	58	66	462	73	272	0.29
18	230	50	2600	42.3	0.32	54	62	358	195	211	0.78
19	230	50	2600	36.9	0.28	61	69	179	287	105	1.15
20	230	50	2600	18.8	0.16			2.9	325	2	1.30

U = Power supply · n = Speed (rpm) · P_{ed} = Power consumption · I = Current draw · LpA_{in} = Sound pressure level intake side · LwA_{in} = Sound power level intake side · q_v = Air flow
p_{fs} = Pressure increase

* Ambient temperature 50 °C: 0-100Pa, 820-853CMH

