

8317080795

EC centrifugal fan - RadiCal

backward-curved, single-intake



8317080795 ebmpapst Datasheet FansCo
sales@fansco.com
www.fansco.com

Nominal data

Type	8317080795	
Motor	M3G150-FF	
Phase		3~
Nominal voltage	VAC	400
Nominal voltage range	VAC	380 .. 480
Frequency	Hz	50/60
Method of obtaining data		ml
Status		prelim.
Speed (rpm)	min ⁻¹	1780
Power consumption	W	3350
Current draw	A	5.1
Min. ambient temperature	°C	-40
Max. ambient temperature	°C	50

ml = Max. load · me = Max. efficiency · fa = Free air · cs = Customer specification · ce = Customer equipment
Subject to change



Technical description

Size	
Motor size	560 mm
Rotor surface	150
Electronics housing material	Painted black
Impeller material	Die-cast aluminum
Number of blades	PP plastic
Direction of rotation	6
Degree of protection Insulation class	Clockwise, viewed toward rotor
Moisture (F) / Environmental (H) protection class	IP55
Ambient temperature note	H1
	Occasional start-up at temperatures between -40°C and -25°C is permitted. For continuous operation at ambient temperatures below -25°C (such as refrigeration applications), use must be made of a fan design with special low-temperature bearings.
Max. permitted ambient temp. for motor (transport/storage)	+80 °C
Min. permitted ambient temp. for motor (transport/storage)	-40 °C
Installation position	Shaft horizontal or rotor on bottom; rotor on top on request
Condensation drainage holes	On rotor side
Mode	S1
Motor bearing	Ball bearing
Technical features	<ul style="list-style-type: none"> - Operation and alarm display with LED - External 15-50 VDC input (parameterization) - Alarm relay - Integrated PI controller - Configurable inputs/outputs (I/O) - MODBUS V6.0 - Motor current limitation - RFID - ISO 15693 compatible - RS-485 MODBUS-RTU - Soft start - Voltage output 3.3-24 VDC, Pmax = 800 mW - Control interface with SELV potential safely disconnected from the mains - Thermal overload protection for electronics/motor - Line undervoltage / phase failure detection
EMC immunity to interference	According to EN 61000-6-2 (industrial environment)
EMC interference emission	According to EN 61000-6-3 (household environment), except EN 61000-3-2 for professionally used equipment with a total rated power greater than 1 kW
Touch current according to IEC 60990 (measuring circuit Fig. 4, TN system)	<= 3.5 mA
Electrical hookup	Terminal box
Protection class	I (with customer connection of protective earth)
Conformity with standards	EN 61800-5-1;CE
Approval	EAC ; UL 1004-7 + 60730-1; CSA C22.2 No. 77 + CAN/CSA-E60730-1

Product drawing

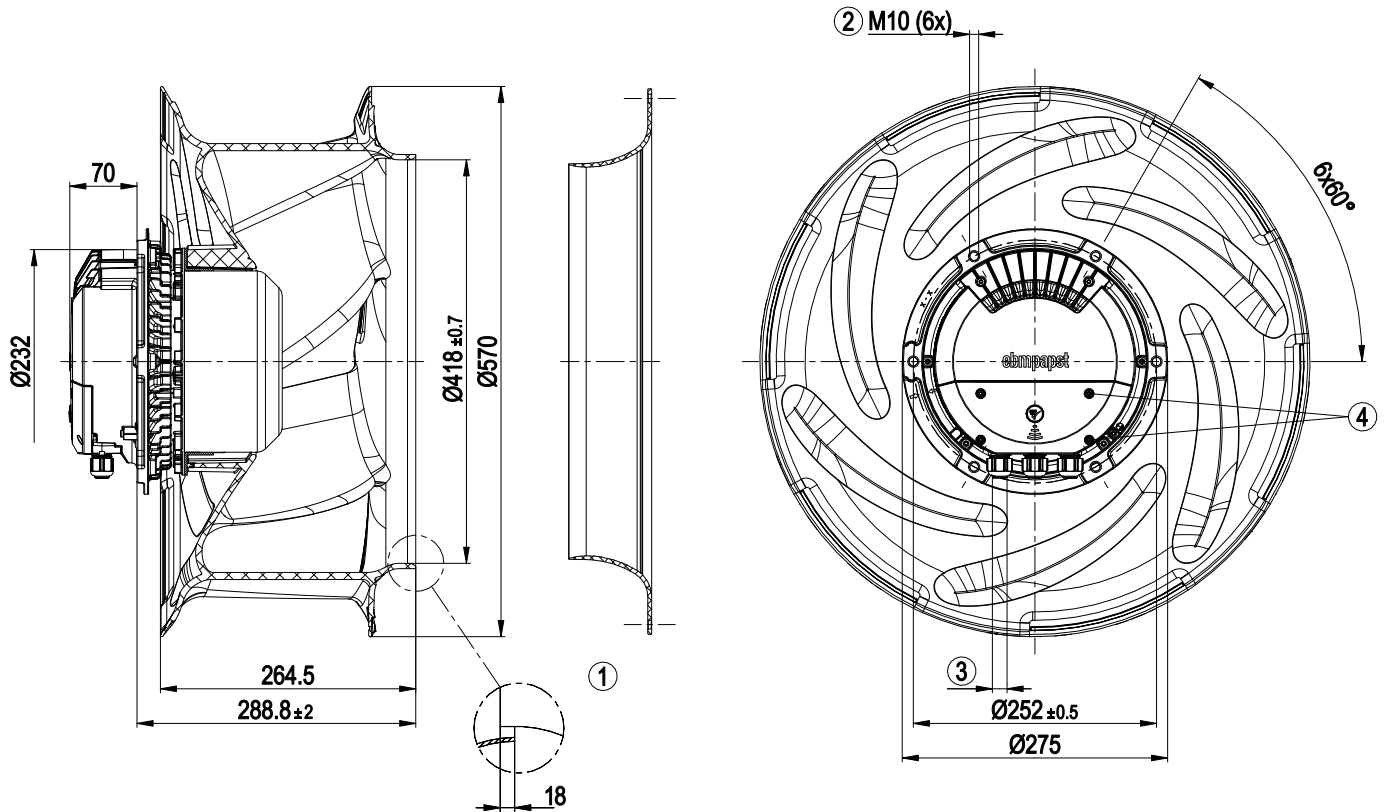

1	Accessory part: Inlet ring 56902-2-2943 not included in scope of delivery
2	Max. clearance for screw 20 mm
3	Cable diameter min. 4 mm, max. 10 mm, tightening torque 4 ± 0.6 Nm
4	Tightening torque 1.5 ± 0.2 Nm

Accessory part

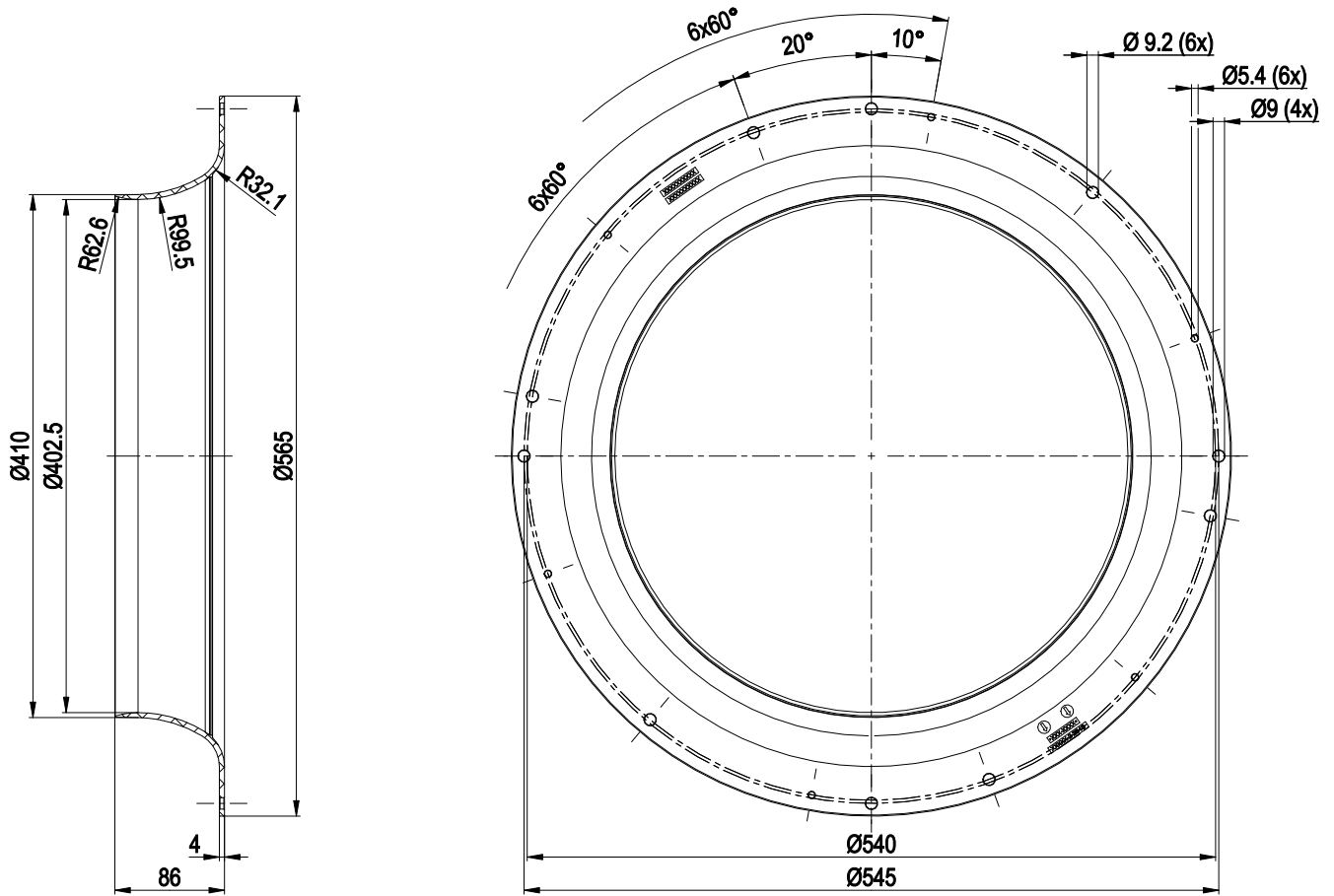

Inlet ring 56902-2-2943, tightening torque 5.5±0.8Nm for M5 screw

Connection diagram

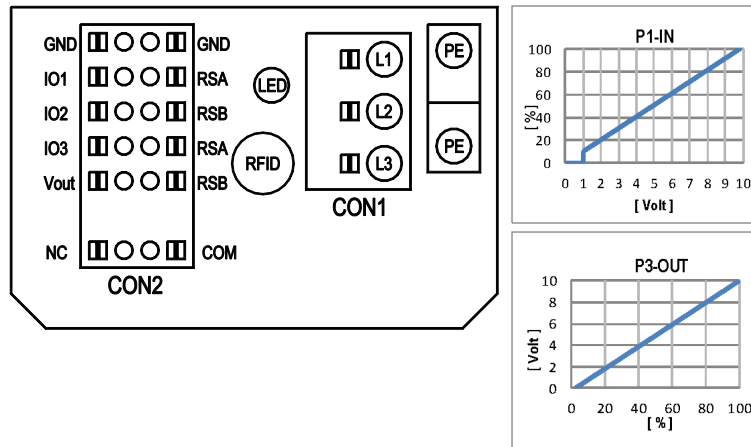

No.	Conn.	Designation	Function/assignment
	CON1	L1, L2, L3	Power supply, phase, see nameplate for voltage range
	PE	PE	Protective earth
	CON2	RSA	RS485 interface for MODBUS, RSA; SELV
	CON2	RSB	RS485 interface for MODBUS, RSB; SELV
	CON2	GND	Reference ground for control interface, SELV
	CON2	IO1	Function parameterizable (see "Optional interface functions" table) Factory setting: Digital input - high active, function: Disable input, SELV - inactive: Pin open or applied voltage < 1.5 VDC - active: applied voltage 3.5-50 VDC Reset function: Triggering of error reset on change of state from "enabled" to "disabled"
	CON2	IO2	Function parameterizable (see "Optional interface functions" table) Factory setting: Analog input 0-10 V / PWM, Ri=100 kΩ, function: Set value Characteristic curve parameterizable (see input characteristic curve P1-IN), SELV
	CON2	IO3	Function parameterizable (see "Optional interface functions" table) Factory setting: Analog output 0-10 V, max. 5 mA, function: Fan modulation level Characteristic curve parameterizable (see output characteristic curve P3-OUT), SELV
	CON2	Vout	Voltage output 3.3-24 VDC ±5%, Pmax=800 mW, voltage parameterizable Factory setting: 10 VDC short-circuit-proof, supply for external devices, SELV alternatively: 15-50 VDC input for parameterization via MODBUS without line voltage
	CON2	COM	Status relay, floating status contact, common connection, contact rating 250 VAC / 2 A (AC1) / min. 10 mA, reinforced insulation on supply side and on control interface side
	CON2	NC	Status relay, floating status contact, break for failure
		LED	green: status = good, ready for operation orange: status = warning red: status = failure
		P1-IN	Input characteristic curve
		P3-OUT	Output characteristic curve

Terminal/plug assignment

CON2	configurable IO functions: normal / inverse	MODBUS Register for IO mode configuration	electrical specification	configurable IO mode		INPUT		OUTPUT								
				source: set value	source: sensor value	switch: parameter set: #1 / #2	switch: control function: heating (pos.), cooling (neg.)	switch: direction of rotation: cw / ccw	switch: set value source	switch: fan enable / disable	signal: tach out	signal: diagnostics out	signal: fan modulation level %	signal: actual speed	signal: system modulation level %	signal: remote control output 0-10V
101	<ul style="list-style-type: none"> Din1 (active high): digital input Ain1 0-10V/PWM: analog input Tach out (open collector output) Diagnostics out (open collector output) 	D158 [0]	not active: pin open or applied voltage < 1.5VDC	source: set value	switch: parameter set: #1 / #2	switch: direction of rotation: cw / ccw	switch: set value source	switch: fan enable / disable	signal: tach out	signal: diagnostics out	signal: fan modulation level %	signal: actual speed	signal: system modulation level %	signal: remote control output 0-10V	pulse input for auto-addressing	pulse output for auto-addressing
			active: applied voltage 3.5-50VDC, SELV	source: sensor value	switch: control function: heating (pos.), cooling (neg.)	switch: direction of rotation: cw / ccw	switch: set value source	switch: fan enable / disable	signal: tach out	signal: diagnostics out	signal: fan modulation level %	signal: actual speed	signal: system modulation level %	signal: remote control output 0-10V	pulse input for auto-addressing	pulse output for auto-addressing
			Ri=100K, characteristic curve parameterizable, $f_{PWM}=1k..10kHz$, SELV	source: sensor value	switch: control function: heating (pos.), cooling (neg.)	switch: direction of rotation: cw / ccw	switch: set value source	switch: fan enable / disable	signal: tach out	signal: diagnostics out	signal: fan modulation level %	signal: actual speed	signal: system modulation level %	signal: remote control output 0-10V	pulse input for auto-addressing	pulse output for auto-addressing
			Umax=50VDC, Imax=20mA, SELV	source: sensor value	switch: control function: heating (pos.), cooling (neg.)	switch: direction of rotation: cw / ccw	switch: set value source	switch: fan enable / disable	signal: tach out	signal: diagnostics out	signal: fan modulation level %	signal: actual speed	signal: system modulation level %	signal: remote control output 0-10V	pulse input for auto-addressing	pulse output for auto-addressing
102	<ul style="list-style-type: none"> Din2 (active high): digital input Ain2 0-10V/PWM: analog input Ain2 4-20mA: analog input 	D158 [2] D158 [5] D158 [6]	not active: pin open or applied voltage < 1.5VDC	source: set value	switch: parameter set: #1 / #2	switch: direction of rotation: cw / ccw	switch: set value source	switch: fan enable / disable	signal: tach out	signal: diagnostics out	signal: fan modulation level %	signal: actual speed	signal: system modulation level %	signal: remote control output 0-10V	pulse input for auto-addressing	pulse output for auto-addressing
			active: applied voltage 3.5-50VDC, SELV	source: sensor value	switch: control function: heating (pos.), cooling (neg.)	switch: direction of rotation: cw / ccw	switch: set value source	switch: fan enable / disable	signal: tach out	signal: diagnostics out	signal: fan modulation level %	signal: actual speed	signal: system modulation level %	signal: remote control output 0-10V	pulse input for auto-addressing	pulse output for auto-addressing
103	<ul style="list-style-type: none"> Din3 (active high): digital input Din3 (active low): digital input PWMIn3: digital input Aout3 0-10V: analog output Tacho out (pulses): analog output Diagnostics out (pulses) 	D159 [0] D159 [2] D159 [3] D15A [0] D15A [1] D15A [7]	not active: pin open or applied voltage < 1.5VDC	source: set value	switch: parameter set: #1 / #2	switch: direction of rotation: cw / ccw	switch: set value source	switch: fan enable / disable	signal: tach out	signal: diagnostics out	signal: fan modulation level %	signal: actual speed	signal: system modulation level %	signal: remote control output 0-10V	pulse input for auto-addressing	pulse output for auto-addressing
			active: applied voltage 3.5-50VDC, SELV	source: sensor value	switch: control function: heating (pos.), cooling (neg.)	switch: direction of rotation: cw / ccw	switch: set value source	switch: fan enable / disable	signal: tach out	signal: diagnostics out	signal: fan modulation level %	signal: actual speed	signal: system modulation level %	signal: remote control output 0-10V	pulse input for auto-addressing	pulse output for auto-addressing
			not active: pin open or applied voltage < 1.5VDC	source: sensor value	switch: control function: heating (pos.), cooling (neg.)	switch: direction of rotation: cw / ccw	switch: set value source	switch: fan enable / disable	signal: tach out	signal: diagnostics out	signal: fan modulation level %	signal: actual speed	signal: system modulation level %	signal: remote control output 0-10V	pulse input for auto-addressing	pulse output for auto-addressing
			40Hz - 10kHz, characteristics parameterizable	source: sensor value	switch: control function: heating (pos.), cooling (neg.)	switch: direction of rotation: cw / ccw	switch: set value source	switch: fan enable / disable	signal: tach out	signal: diagnostics out	signal: fan modulation level %	signal: actual speed	signal: system modulation level %	signal: remote control output 0-10V	pulse input for auto-addressing	pulse output for auto-addressing
RSA RSB	RS485 bus connection,	D15A [4] D15A [5] D15A [6]	not active: pin open or applied voltage < 1.5VDC	source: set value	switch: parameter set: #1 / #2	switch: direction of rotation: cw / ccw	switch: set value source	switch: fan enable / disable	signal: tach out	signal: diagnostics out	signal: fan modulation level %	signal: actual speed	signal: system modulation level %	signal: remote control output 0-10V	pulse input for auto-addressing	pulse output for auto-addressing
			active: applied voltage < 1.5VDC, SELV	source: sensor value	switch: control function: heating (pos.), cooling (neg.)	switch: direction of rotation: cw / ccw	switch: set value source	switch: fan enable / disable	signal: tach out	signal: diagnostics out	signal: fan modulation level %	signal: actual speed	signal: system modulation level %	signal: remote control output 0-10V	pulse input for auto-addressing	pulse output for auto-addressing
Vout	voltage output alternatively: input auxiliary power supply for parameterization via RS485/MODBUS RTU without line voltage	D16E [..]	voltage parameterizable 3.3...24VDC +/- 5.5%, Pmax=800mW, short-circuit-proof, supply for external devices, SELV	source: set value	switch: parameter set: #1 / #2	switch: direction of rotation: cw / ccw	switch: set value source	switch: fan enable / disable	signal: tach out	signal: diagnostics out	signal: fan modulation level %	signal: actual speed	signal: system modulation level %	signal: remote control output 0-10V	pulse input for auto-addressing	pulse output for auto-addressing
			15...50VDC	source: sensor value	switch: control function: heating (pos.), cooling (neg.)	switch: direction of rotation: cw / ccw	switch: set value source	switch: fan enable / disable	signal: tach out	signal: diagnostics out	signal: fan modulation level %	signal: actual speed	signal: system modulation level %	signal: remote control output 0-10V	pulse input for auto-addressing	pulse output for auto-addressing

o configurable option

For further information and additional functions see EC Control Software: Fan-Set-App. or MODBUS Parameter Specification V6.0



Curves: Air performance 50 Hz

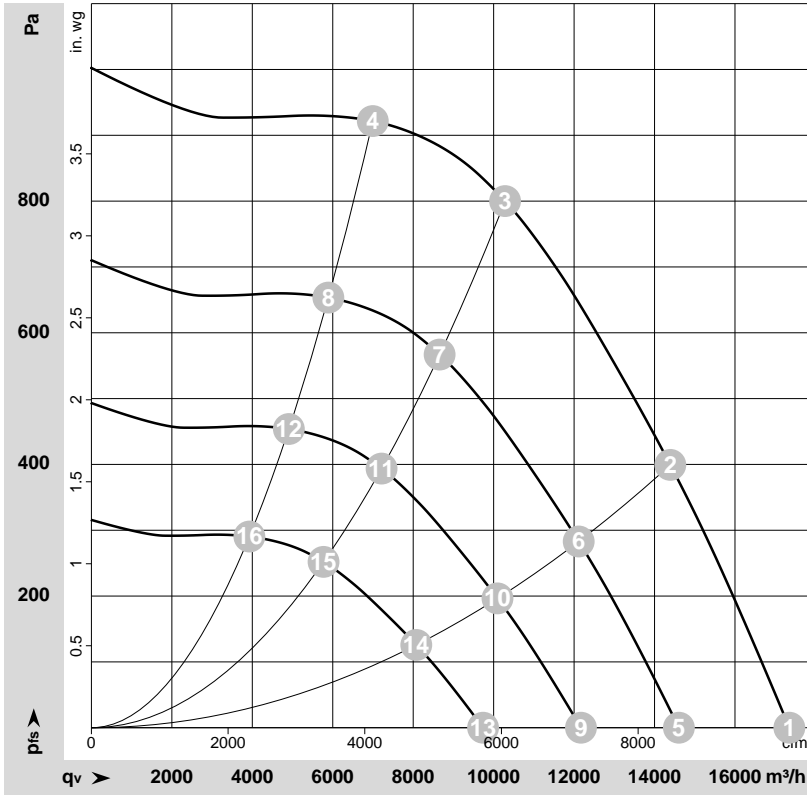

Fan performance

	Wired	U	f	n	P _{ed}	I	LpA _{in}	LwA _{in}	LwA _{out}	q _v	p _{fs}	q _v	p _{fs}
		V	Hz	min ⁻¹	W	A	dB(A)	dB(A)	dB(A)	m ³ /h	Pa	cfm	in. wg
1	3~	400	50	1780	1835	2.89	87	92	96	17350	0	10210	0.00
2	3~	400	50	1780	2817	4.33	79	86	91	14390	400	8470	1.61
3	3~	400	50	1780	3350	5.10	71	78	84	10285	800	6055	3.21
4	3~	400	50	1780	3094	4.75	78	85	89	6995	920	4120	3.69
5	3~	400	50	1500	1094	1.72	82	88	92	14605	0	8595	0.00
6	3~	400	50	1500	1680	2.59	75	82	86	12115	286	7130	1.15
7	3~	400	50	1500	1984	3.04	66	74	80	8655	569	5095	2.28
8	3~	400	50	1500	1847	2.83	74	80	85	5890	654	3465	2.63
9	3~	400	50	1250	633	1.00	78	83	87	12170	0	7165	0.00
10	3~	400	50	1250	972	1.50	70	77	82	10095	199	5940	0.80
11	3~	400	50	1250	1148	1.76	62	69	76	7215	395	4245	1.59
12	3~	400	50	1250	1069	1.64	69	76	80	4910	454	2890	1.82
13	3~	400	50	1000	324	0.51	72	77	82	9735	0	5730	0.00
14	3~	400	50	1000	498	0.77	64	71	76	8075	127	4755	0.51
15	3~	400	50	1000	588	0.90	56	63	70	5770	253	3395	1.02
16	3~	400	50	1000	547	0.84	63	70	74	3925	291	2310	1.17

Wired = Wiring · U = Voltage · f = Frequency · n = Speed (rpm) · P_{ed} = Power consumption · I = Current draw · LpA_{in} = Sound pressure level intake side · LwA_{in} = Sound power level intake side
LwA_{out} = Sound power level outlet side · q_v = Air flow · p_{fs} = Pressure increase