

8317077489

AC axial fan

sickle-shaped blades (S series)
with guard grille for short nozzle

8317077489 ebmpapst Datasheet
sales@fansco.com
www.fansco.com

Nominal data

Type	8317077489				
Motor	M4D110-GF				
Phase		3~	3~	3~	3~
Nominal voltage	VAC	400	400	480	480
Wiring		Δ	Y	Δ	Y
Frequency	Hz	50	50	60	60
Method of obtaining data		ml	ml	ml	ml
Valid for approval/standard		-	-	-	-
Speed (rpm)	min ⁻¹	1325	1035	1570	1170
Power consumption	W	820	550	1220	770
Current draw	A	1.59	0.95	1.86	1.13
Max. back pressure	Pa	160	100	150	84
Max. back pressure	in. wg	0.64	0.4	0.6	0.34
Min. ambient temperature	°C	-40	-40	-40	-40
Max. ambient temperature	°C	60	60	60	60
Starting current	A	6.5	2	7.5	2.2

ml = Max. load · me = Max. efficiency · fa = Free air · cs = Customer specification · ce = Customer equipment
Subject to change



8317077489

AC axial fan

sickle-shaped blades (S series)
with guard grille for short nozzle

Technical description

Weight	13.4 kg
Size	500 mm
Motor size	110
Rotor surface	Cast in aluminum
Terminal box material	PP plastic
Blade material	Sheet aluminum
Guard grille material	Steel, coated with black plastic (RAL 9005)
Number of blades	5
Blade pitch	0
Airflow direction	V
Direction of rotation	Counterclockwise, viewed toward rotor
Degree of protection	IP54
Insulation class	"F"
Moisture (F) / Environmental (H) protection class	H2
Ambient temperature note	Occasional start-up at temperatures between -40°C and -25°C is permitted. For continuous operation at ambient temperatures below -25°C (such as refrigeration applications), use must be made of a fan design with special low-temperature bearings.
Max. permitted ambient temp. for motor (transport/storage)	+80 °C
Min. permitted ambient temp. for motor (transport/storage)	-40 °C
Installation position	Shaft horizontal or rotor on bottom; rotor on top on request
Condensation drainage holes	On rotor side
Mode	S1
Motor bearing	Ball bearing
Touch current according to IEC 60990 (measuring circuit Fig. 4, TN system)	<= 3.5 mA
Electrical hookup	Terminal box
Motor protection	Thermal overload protector (TOP) with basic insulation
With cable	Axial
Protection class	I (with customer connection of protective earth)
Approval	CCC



AC axial fan

sickle-shaped blades (S series)
with guard grille for short nozzle

Product drawing

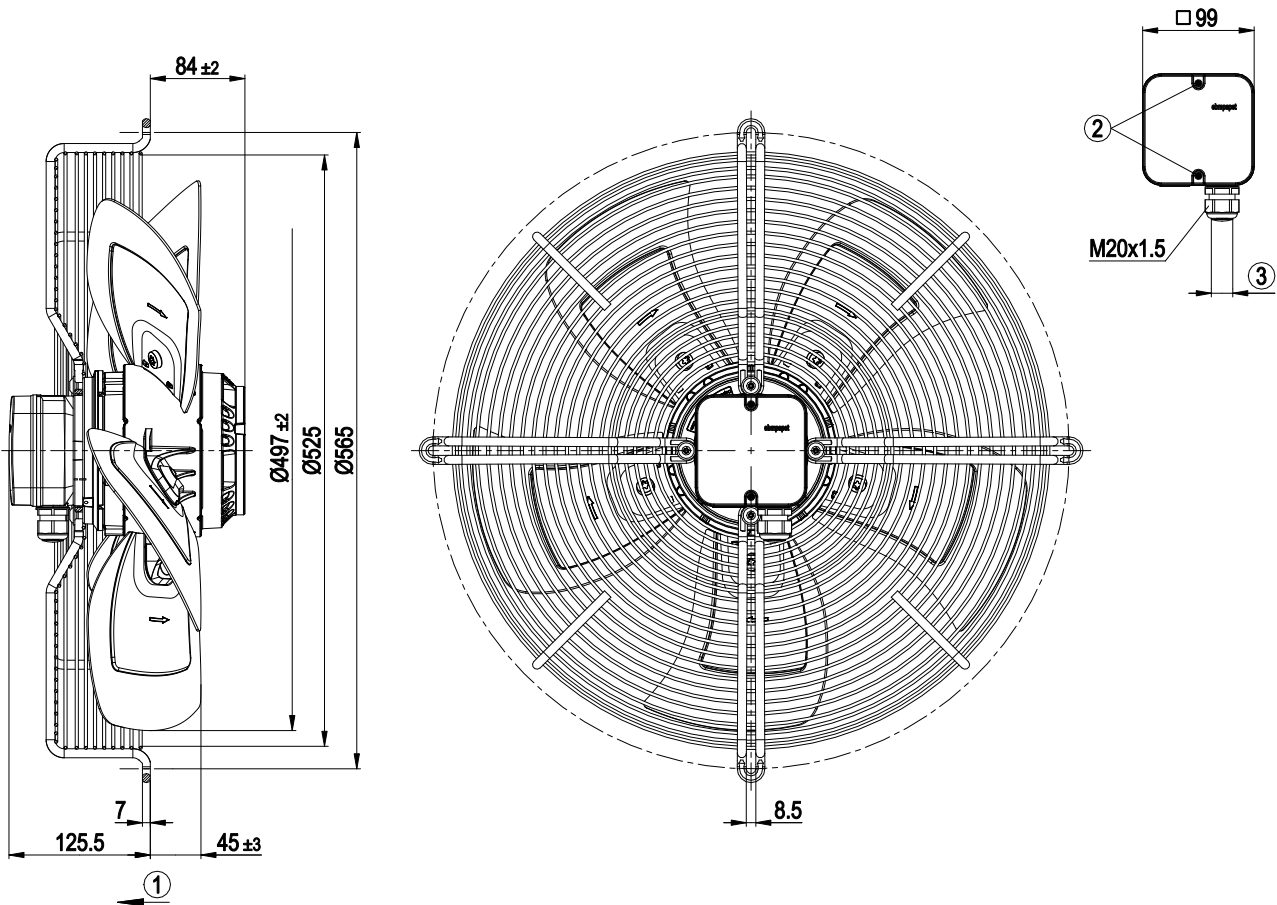

1	Direction of air flow "V"
2	Tightening torque 1.5 ± 0.2 Nm
3	Cable diameter min. 6 mm, max. 12 mm, tightening torque 2 ± 0.3 Nm

AC axial fan

sickle-shaped blades (S series)
with guard grille for short nozzle

Connection diagram

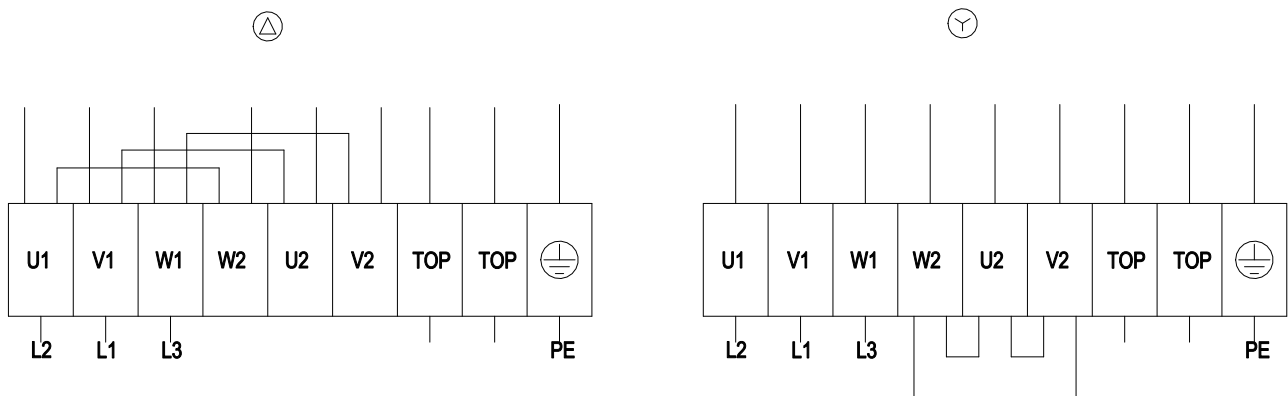

Δ	Delta connection	Y	Star connection	L1	= V1 = blue
L2	= U1 = black	L3	= W1 = brown	W2	yellow
U2	green	V2	white	TOP	2x gray
PE	green/yellow				

AC axial fan

sickle-shaped blades (S series)
with guard grille for short nozzle

Curves: Air performance 50 Hz

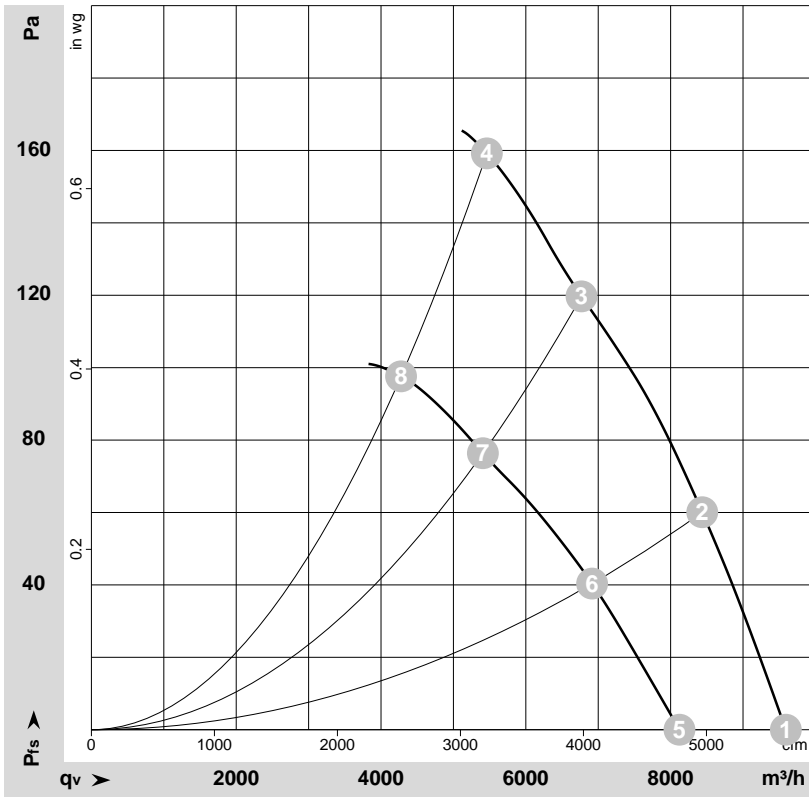

$\rho = 1.15 \text{ kg/m}^3 \pm 2 \%$

Measurement: LU-100710-1
Measurement: LU-100714-1

Air performance measured according to ISO 5801 installation category A. For detailed information on the measurement setup, contact ebm-papst. Intake sound level: Sound power level according to ISO 13347 / sound pressure level measured at 1 m distance from fan axis. The values given are valid under the specified measuring conditions and may vary due to conditions of installation. For deviations from the standard configuration, the parameters have to be checked on the installed unit.

Measured values

	Wired	U	f	n	P _e	I	LpA _{out}	LwA _{out}	qv	P _{fs}	qv	P _{fs}
		V	Hz	min ⁻¹	W	A	dB(A)	dB(A)	m ³ /h	Pa	CFM	inH ₂ O
1	Δ	400	50	1380	615	1.28	80	80	9590	0	5645	0.00
2	Δ	400	50	1360	687	1.37	79	81	8435	60	4965	0.24
3	Δ	400	50	1345	753	1.44	70	80	6770	120	3985	0.48
4	Δ	400	50	1325	820	1.59	73	85	5460	160	3215	0.64
5	Y	400	50	1160	454	0.76	76	76	8120	0	4780	0.00
6	Y	400	50	1115	492	0.82	73	77	6915	41	4070	0.16
7	Y	400	50	1070	521	0.87	70	77	5405	76	3180	0.31
8	Y	400	50	1035	550	0.95	63	75	4275	98	2515	0.39

Wired = Wiring · U = Power supply · f = Frequency · n = Speed (rpm) · P_e = Power consumption · I = Current draw · LpA_{out} = Sound pressure level outtake side · LwA_{out} = Sound power level outtake side
qv = Air flow · P_{fs} = Pressure increase



AC axial fan

sickle-shaped blades (S series)
with guard grille for short nozzle

Curves: Air performance 60 Hz

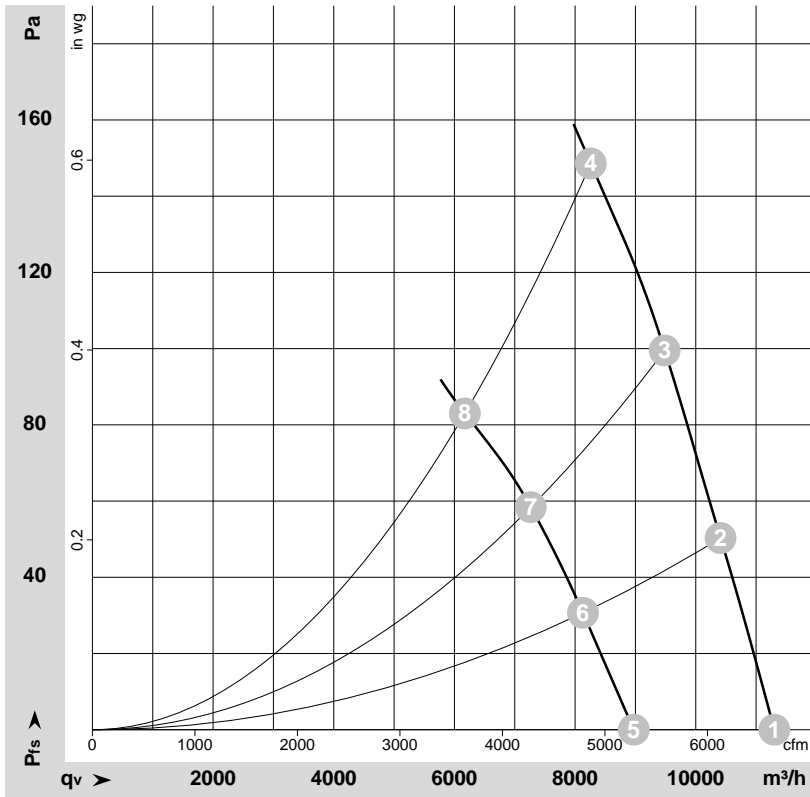

$$\rho = 1.15 \text{ kg/m}^3 \pm 2 \%$$

Measurement: LU-100711-1
Measurement: LU-100715-1

Air performance measured according to ISO 5801 installation category A. For detailed information on the measurement setup, contact ebm-papst. Intake sound level: Sound power level according to ISO 13347 / sound pressure level measured at 1 m distance from fan axis. The values given are valid under the specified measuring conditions and may vary due to conditions of installation. For deviations from the standard configuration, the parameters have to be checked on the installed unit.

Measured values

	Wired	U	f	n	P _e	I	LpA _{out}	LwA _{out}	q _v	P _{fs}	q _v	P _{fs}
		V	Hz	min ⁻¹	W	A	dB(A)	dB(A)	m ³ /h	Pa	cfm	in. wg
1	Δ	480	60	1620	996	1.54	83	85	11300	0	6650	0.00
2	Δ	480	60	1605	1072	1.63	82	84	10410	50	6130	0.20
3	Δ	480	60	1590	1142	1.70	82	85	9485	100	5585	0.40
4	Δ	480	60	1570	1220	1.86	81	84	8260	150	4860	0.60
5	Y	480	60	1285	695	0.97	79	79	8975	0	5280	0.00
6	Y	480	60	1250	724	1.02	79	79	8130	31	4785	0.12
7	Y	480	60	1210	749	1.06	72	79	7265	58	4275	0.23
8	Y	480	60	1170	770	1.13	72	78	6175	83	3635	0.33

Wired = Wiring · U = Voltage · f = Frequency · n = Speed (rpm) · P_e = Power consumption · I = Current draw · LpA_{out} = Sound pressure level outtake side · LwA_{out} = Sound power level outtake side
q_v = Air flow · P_{fs} = Pressure increase