

8317076823

AC axial fan

sickled blades (S series)
with guard grille for short nozzle



8317076823 ebmpapst Datasheet
sales@fansco.com
www.fansco.com

Nominal data

Type	8317076823		
Motor	M4E074-EI		
Phase		1~	1~
Nominal voltage	VAC	230	230
Frequency	Hz	50	60
Type of data definition		fa	fa
Valid for approval / standard		CE	CE
Speed	min ⁻¹	1430	1700
Power input	W	160	240
Current draw	A	0.73	1.06
Motor capacitor	μF	6	6
Capacitor voltage	VDB	400	400
Max. back pressure	Pa	150	75
Min. ambient temperature	°C	-40	-40
Max. ambient temperature	°C	40	40
Starting current	A	2.0	1.9

ml = Max. load · me = Max. efficiency · fa = Running at free air · cs = Customer specs · cu = Customer unit
Subject to alterations

Data according to ErP directive

Installation category	A
Efficiency category	Static
Variable speed drive	No
Specific ratio*	1.00

* Specific ratio = $1 + p_g / 100\,000\text{ Pa}$

		Actual	Request 2013	Request 2015
Overall efficiency η_{es}	%	31.9	25.3	29.3
Efficiency grade N		42.6	36	40
Power input P_e	kW	0.2		
Air flow q_v	m ³ /h	2675		
Pressure increase p_{fs}	Pa	90		
Speed n	min ⁻¹	1390		

Data definition with optimum efficiency. LU-30924
The ErP data is determined using a motor-impeller combination in a standardised measurement configuration.



AC axial fan

sickled blades (S series)
with guard grille for short nozzle

Technical features

Mass	5.9 kg
Size	400 mm
Surface of rotor	Coated in black
Material of terminal box	ABS plastic, black
Material of blades	Sheet steel, coated in black
Material of guard grille	Steel, phosphated and coated in black plastic
Number of blades	5
Direction of air flow	"V"
Direction of rotation	Counter-clockwise, seen on rotor
Type of protection	IP 44; Depending on installation and position as per EN 60034-5
Insulation class	"B"
Humidity class	H0+
Max. permissible ambient motor temp. (transp./ storage)	+ 60 °C
Min. permissible ambient motor temp. (transp./storage)	- 40 °C
Mounting position	Shaft horizontal or rotor on bottom; rotor on top on request
Condensate discharge holes	Rotor-side
Operation mode	S1
Motor bearing	Ball bearing with anti-freezing grease
Touch current acc. IEC 60990 (measuring network Fig. 4, TN system)	< 0.75 mA
Electrical leads	Via terminal box, integrated capacitor connected via terminal box
Motor protection	Thermal overload protector (TOP) wired internally
Cable exit	Variable
Protection class	I (if protective earth is connected by customer)
Approval	CCC

AC axial fan

sickled blades (S series)
with guard grille for short nozzle

Product drawing

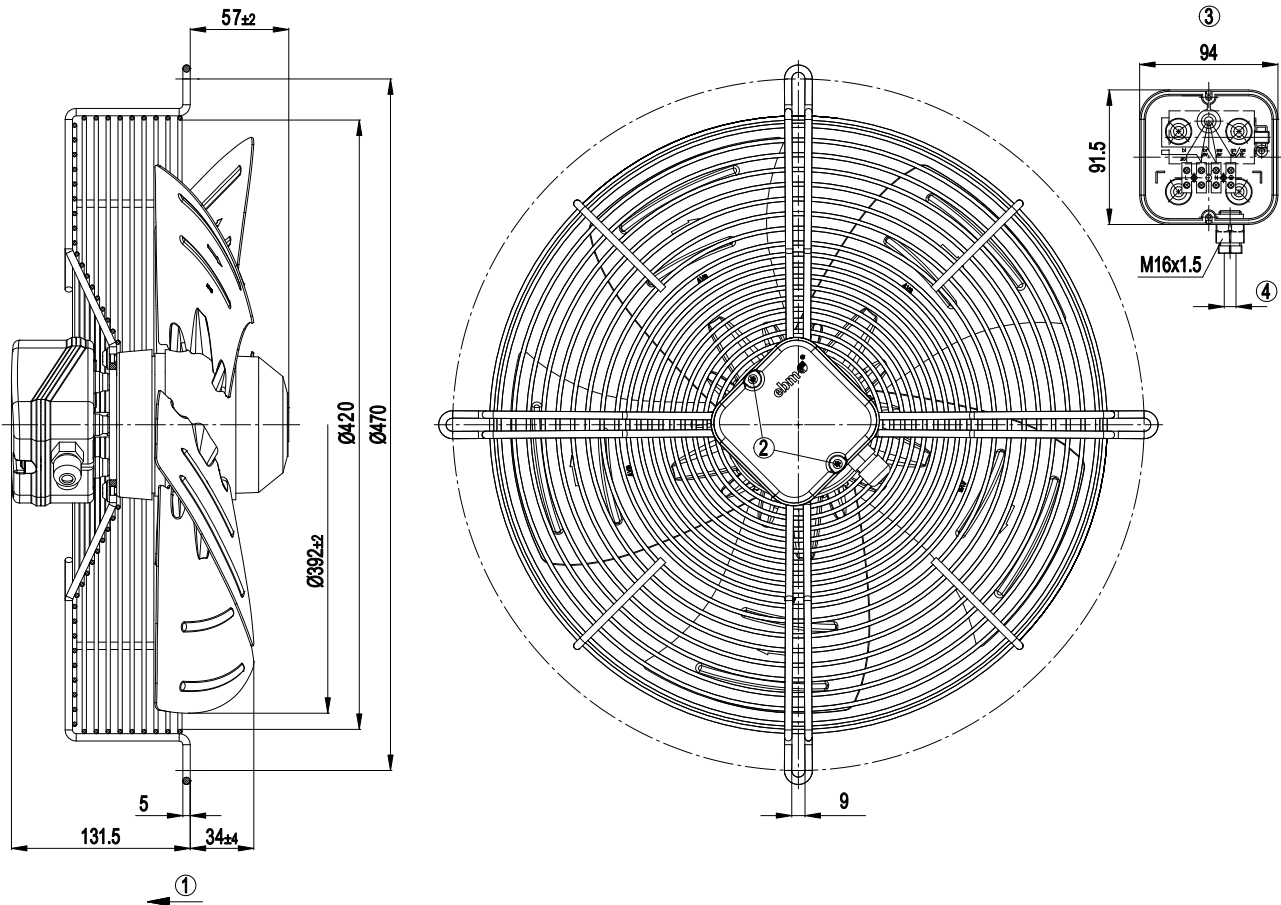

1	Direction of air flow "V"
2	Tightening torque 0,7 ± 0,2 Nm
3	Illustration without terminal box cover
4	Cable diameter max. 7.5 mm; tightening torque 1.3 ± 0.2 Nm

Connection screen

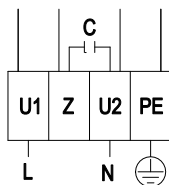

L	= U1 = blue	Z	brown	N	= U2 = black
PE	green/yellow				



AC axial fan

sickle-shaped blades (S series)
with guard grille for short nozzle

Curves: Air performance 50 Hz

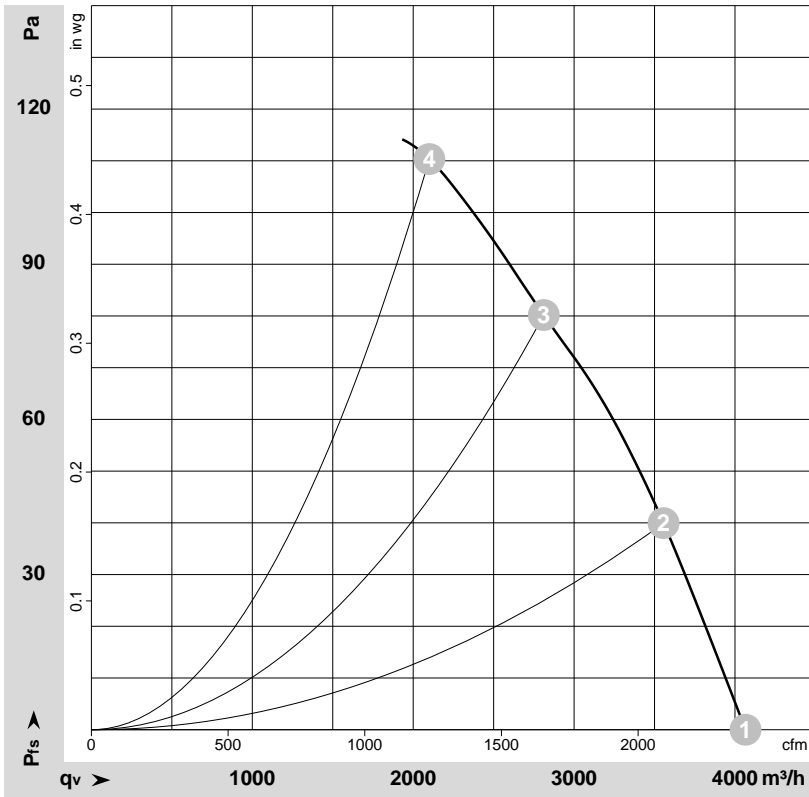

$\rho = 1.15 \text{ kg/m}^3 \pm 2 \%$

Air performance measured according to ISO 5801 installation category A. For detailed information on the measurement setup, contact ebmpapst. Intake sound level: Sound power level according to ISO 13347 / sound pressure level measured at 1 m distance from fan axis. The values given are valid under the specified measuring conditions and may vary due to conditions of installation. For deviations from the standard configuration, the parameters have to be checked on the installed unit.

Measured values

	U	f	n	P _e	I	LpA _{in}	LwA _{in}	LwA _{out}	q _v	P _{fs}	q _v	P _{fs}
	V	Hz	min ⁻¹	W	A	dB(A)	dB(A)	dB(A)	m ³ /h	Pa	cfm	inH ₂ O
1	230	50	1430	160	0.73	68	74	74	4065	0	2395	0.00
2	230	50	1410	189	0.84	66	72	72	3555	40	2095	0.16
3	230	50	1390	207	0.92	65	72	72	2810	80	1655	0.32
4	230	50	1370	225	0.99	64	71	71	2100	110	1235	0.44

U = Power supply · f = Frequency · n = Speed (rpm) · P_e = Power consumption · I = Current draw · LpA_{in} = Sound pressure level intake side · LwA_{in} = Sound power level intake side
LwA_{out} = Sound power level outlet side · q_v = Air flow · p_{fs} = Pressure increase



AC axial fan

sickle-shaped blades (S series)
with guard grille for short nozzle

Curves: Air performance 60 Hz

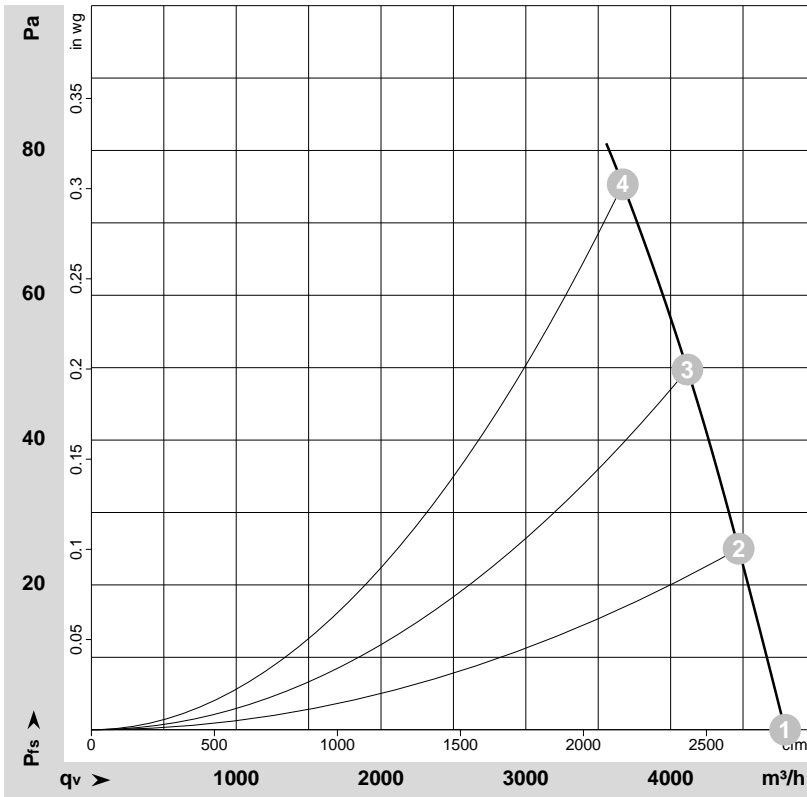

$\rho = 1.15 \text{ kg/m}^3 \pm 2 \%$

Air performance measured according to ISO 5801 installation category A. For detailed information on the measurement setup, contact ebmpapst. Intake sound level: Sound power level according to ISO 13347 / sound pressure level measured at 1 m distance from fan axis. The values given are valid under the specified measuring conditions and may vary due to conditions of installation. For deviations from the standard configuration, the parameters have to be checked on the installed unit.

Measured values

	U	f	n	P _e	I	LpA _{in}	LwA _{in}	LwA _{out}	q _v	P _{fs}	q _v	P _{fs}
	V	Hz	min ⁻¹	W	A	dB(A)	dB(A)	dB(A)	m ³ /h	Pa	cfm	inH ₂ O
1	230	60	1700	240	1.06	71	78	77	4790	0	2820	0.00
2	230	60	1645	262	1.16	71	77	77	4470	25	2630	0.10
3	230	60	1620	275	1.21	69	75	75	4115	50	2425	0.20
4	230	60	1580	295	1.29	67	74	74	3670	75	2160	0.30

U = Power supply · f = Frequency · n = Speed (rpm) · P_e = Power consumption · I = Current draw · LpA_{in} = Sound pressure level intake side · LwA_{in} = Sound power level intake side
LwA_{out} = Sound power level outlet side · q_v = Air flow · P_{fs} = Pressure increase

