

8317076822

AC axial fan

sickled blades (S series)
with guard grille for short nozzle

8317076822 ebmpapst Datasheet
sales@fansco.com
www.fansco.com

Nominal data

Type	8317076822		
Motor	M4E074-DF		
Phase		1~	1~
Nominal voltage	VAC	230	230
Frequency	Hz	50	60
Type of data definition		fa	fa
Valid for approval / standard		CE	CE
Speed	min ⁻¹	1400	1590
Power input	W	130	190
Current draw	A	0.58	0.83
Motor capacitor	μF	4	4
Capacitor voltage	VDB	400	400
Max. back pressure	Pa	90	60
Min. ambient temperature	°C	-40	-40
Max. ambient temperature	°C	35	35
Starting current	A	1.2	1.1

ml = max. load · me = max. efficiency · fa = running at free air · cs = customer specs · cu = customer unit
Subject to alterations

Data according to ErP directive

Installation category	A
Efficiency category	Static
Variable speed drive	No
Specific ratio*	1.00

* Specific ratio = $1 + p_g / 100\,000\text{ Pa}$

	Actual	Request 2013	Request 2015
Overall efficiency η_{es}	28.5	24.5	28.5
Efficiency grade N	40	36	40
Power input P_e	kW	0.15	
Air flow q_v	m ³ /h	2200	
Pressure increase p_{fs}	Pa	70	
Speed n	min ⁻¹	1345	

Data established at point of optimum efficiency



AC axial fan

sickled blades (S series)
with guard grille for short nozzle

Technical features

Mass	5.2 kg
Size	350 mm
Surface of rotor	Coated in black
Material of terminal box	ABS plastic, black
Material of blades	Sheet steel, coated in black
Material of guard grille	Steel, phosphated and coated in black plastic
Number of blades	5
Direction of air flow	"V"
Direction of rotation	Counter-clockwise, seen on rotor
Type of protection	IP 44
Insulation class	"B"
Humidity class	F1-2
Max. permissible ambient motor temp. (transp./ storage)	+ 70 °C
Min. permissible ambient motor temp. (transp./storage)	-40 °C
Mounting position	Shaft horizontal or rotor on top; rotor on bottom on request
Condensate discharge holes	None
Operation mode	S1
Motor bearing	Ball bearing with anti-freezing grease
Touch current acc. IEC 60990 (measuring network Fig. 4, TN system)	< 0.75 mA
Electrical leads	Via terminal box, integrated capacitor connected via terminal box
Motor protection	Thermal overload protector (TOP) wired internally
Cable exit	Variable
Protection class	I (if protective earth is connected by customer)
Approval	CCC

AC axial fan

sickled blades (S series)
with guard grille for short nozzle

Product drawing

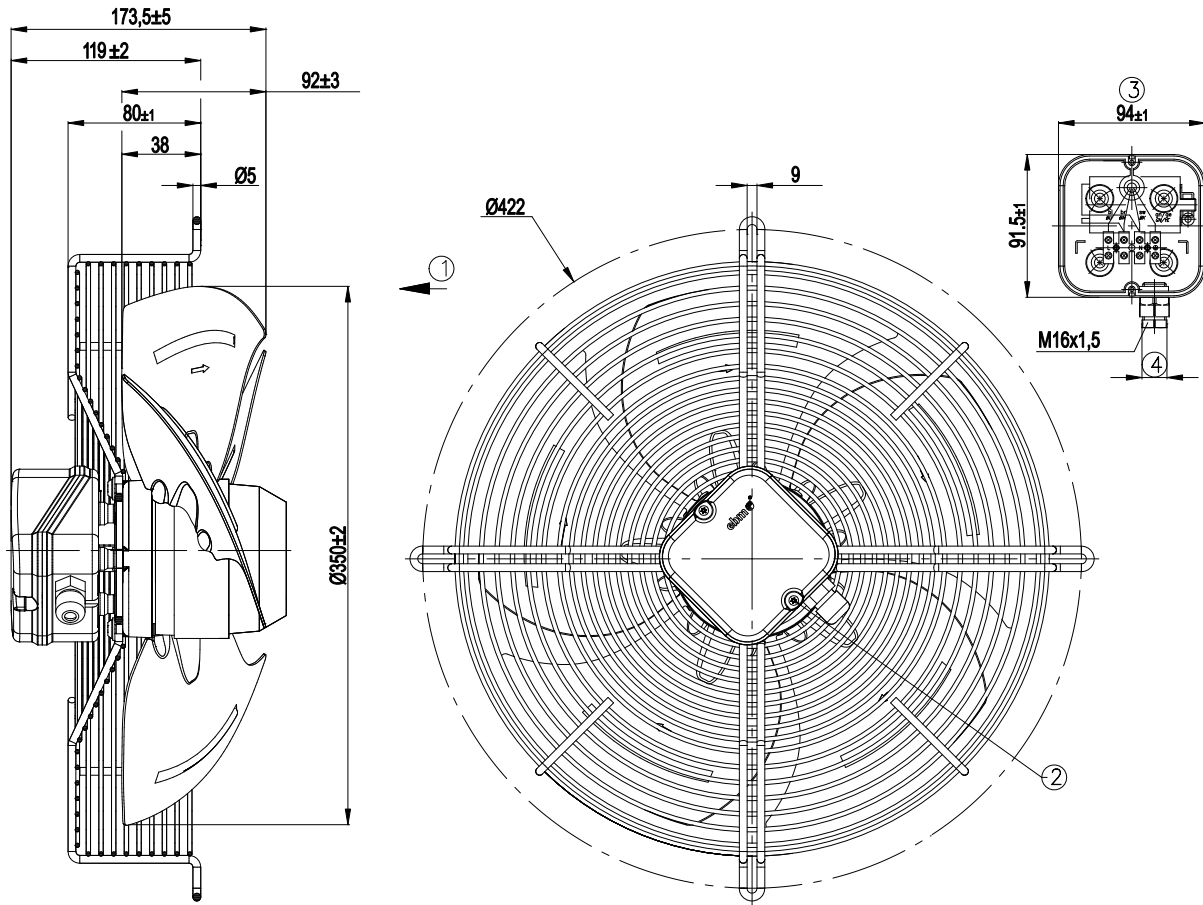

1	Direction of air flow "V"
2	Tightening torque 0.8 Nm
3	Shown without terminal box cover
4	Cable diameter max 7.5 mm; tightening torque 2 Nm



AC axial fan

sickled blades (S series)
with guard grille for short nozzle

Connection screen

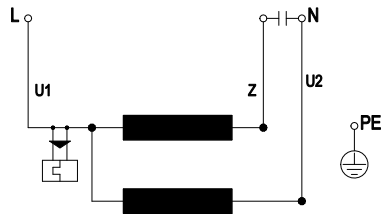

U1	blue	Z	brown	U2	black
PE	green/yellow				

AC axial fan

sickled blades (S series)
with guard grille for short nozzle

Charts: Air flow 50 Hz

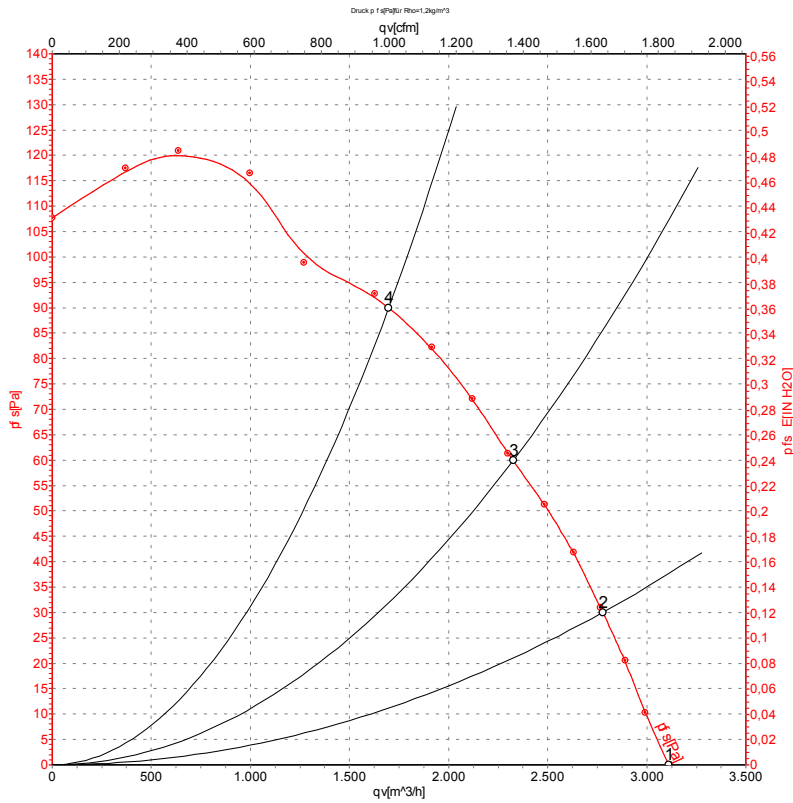

Air performance measured as per ISO 5801 Installation category A. For detailed information on the measuring set-up, please contact ebm-papst. Suction-side noise levels: L_{wA} measured as per ISO 13347 / L_{pA} measured with 1m distance to fan axis. The values given are valid under the measuring conditions mentioned above and may vary according to the actual installation situation. With any deviation from the standard set-up, the specific values have to be checked and reviewed with the unit installed.

Measured values

	U	f	n	P _e	I	qv	P _{fs}
	V	Hz	min ⁻¹	W	A	m ³ /h	Pa
1	230	50	1400	130	0.58	3110	0
2	230	50	1380	140	0.61	2780	30
3	230	50	1355	151	0.66	2325	60
4	230	50	1290	174	0.76	1700	90

U = Supply voltage · f = Frequency · n = Speed · P_e = Power input · I = Current draw · qv = Air flow · P_{fs} = Pressure increase



AC axial fan

sickled blades (S series)
with guard grille for short nozzle

Charts: Air flow 60 Hz

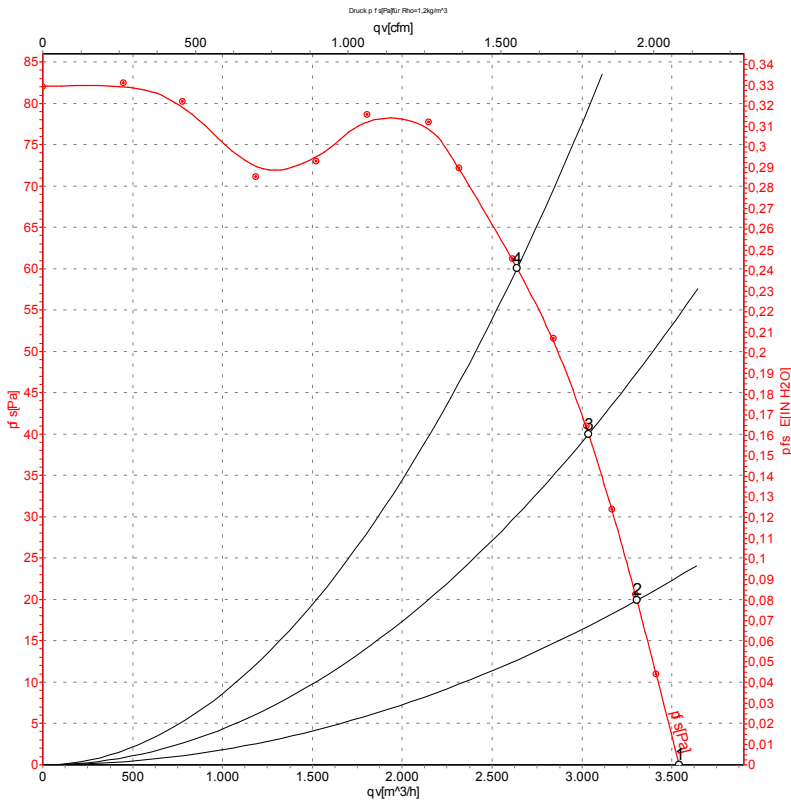

Air performance measured as per ISO 5801 Installation category A. For detailed information on the measuring set-up, please contact ebm-papst. Suction-side noise levels: L_{wA} measured as per ISO 13347 / L_{pA} measured with 1m distance to fan axis. The values given are valid under the measuring conditions mentioned above and may vary according to the actual installation situation. With any deviation from the standard set-up, the specific values have to be checked and reviewed with the unit installed.

Measured values

	U	f	n	P _e	I	qv	P _{fs}
	V	Hz	min ⁻¹	W	A	m ³ /h	Pa
1	230	60	1590	190	0.83	3540	0
2	230	60	1565	196	0.85	3305	20
3	230	60	1520	203	0.88	3035	40
4	230	60	1455	208	0.90	2640	60

U = Supply voltage · f = Frequency · n = Speed · P_e = Power input · I = Current draw · qv = Air flow · p_{fs} = Pressure increase

