

8317072919

AC axial fan

sickle-shaped blades (S series)
with guard grille for short nozzle



8317072919 ebmpapst Datasheet FansCo
sales@fansco.com
www.fansco.com

Nominal data

| | | | |
|-----------------------------|--------------------|------|------|
| Type | 8317072919 | | |
| Motor | M4D074-EI | | |
| Phase | | 3~ | 3~ |
| Nominal voltage | VAC | 230 | 400 |
| Wiring | | Δ | Y |
| Frequency | Hz | 50 | 50 |
| Method of obtaining data | | fa | fa |
| Valid for approval/standard | | CE | CE |
| Speed (rpm) | min ⁻¹ | 1450 | 1450 |
| Power consumption | W | 135 | 135 |
| Current draw | A | 0.76 | 0.44 |
| Max. back pressure | Pa | 105 | 105 |
| Max. back pressure | inH ₂ O | 0.42 | 0.42 |
| Min. ambient temperature | °C | -40 | -40 |
| Max. ambient temperature | °C | 40 | 40 |
| Starting current | A | 3.0 | 1.7 |

ml = Max. load · me = Max. efficiency · fa = Free air · cs = Customer specification · ce = Customer equipment
Subject to change

Data according to ErP Directive

| | | Actual | Req. 2015 |
|-----------------------------------|---|--------|-----------|
| 01 Overall efficiency η_{es} | % | 32.7 | 29.1 |
| 02 Measurement category | | A | |
| 03 Efficiency category | | Static | |
| 04 Efficiency grade N | | 43.6 | 40 |
| 05 Variable speed drive | | No | |

Data obtained at optimum efficiency level.
The ErP data is determined using a motor-impeller combination in a standardized measurement setup.

| | | |
|-------------------------------|-------------------|------|
| 09 Power consumption P_e | kW | 0.19 |
| 09 Air flow q_v | m ³ /h | 2595 |
| 09 Pressure increase p_{fs} | Pa | 91 |
| 10 Speed (rpm) n | min ⁻¹ | 1415 |
| 11 Specific ratio* | | 1.00 |

* Specific ratio = $1 + p_{fs} / 100\,000\text{ Pa}$

LU-27622

AC axial fan

sickle-shaped blades (S series)
with guard grille for short nozzle

Technical description

| | |
|---|--|
| Weight | 5.7 kg |
| Fan size | 400 mm |
| Rotor surface | Painted black |
| Terminal box material | ABS plastic, black |
| Blade material | Sheet steel, painted black |
| Guard grille material | Steel, phosphated and coated with black plastic |
| Number of blades | 5 |
| Airflow direction | "V" |
| Direction of rotation | Counterclockwise, viewed toward rotor |
| Degree of protection | IP44; installation- and position-dependent as per EN 60034-5 |
| Insulation class | "B" |
| Moisture (F) / Environmental (H) protection class | H0+ |
| Max. permitted ambient temp. for motor (transport/storage) | + 70 °C |
| Min. permitted ambient temp. for motor (transport/storage) | - 40 °C |
| Installation position | Shaft horizontal or rotor on bottom; rotor on top on request |
| Condensation drainage holes | On rotor side |
| Mode | S1 |
| Motor bearing | Ball bearing with low-temperature lubricant |
| Touch current according to IEC 60990 (measuring circuit Fig. 4, TN system) | < 0.75 mA |
| Electrical hookup | Via terminal box |
| With cable | Variable |
| Protection class | I (with customer connection of protective earth) |
| Approval | CCC |

AC axial fan

sickle-shaped blades (S series)
with guard grille for short nozzle

Product drawing

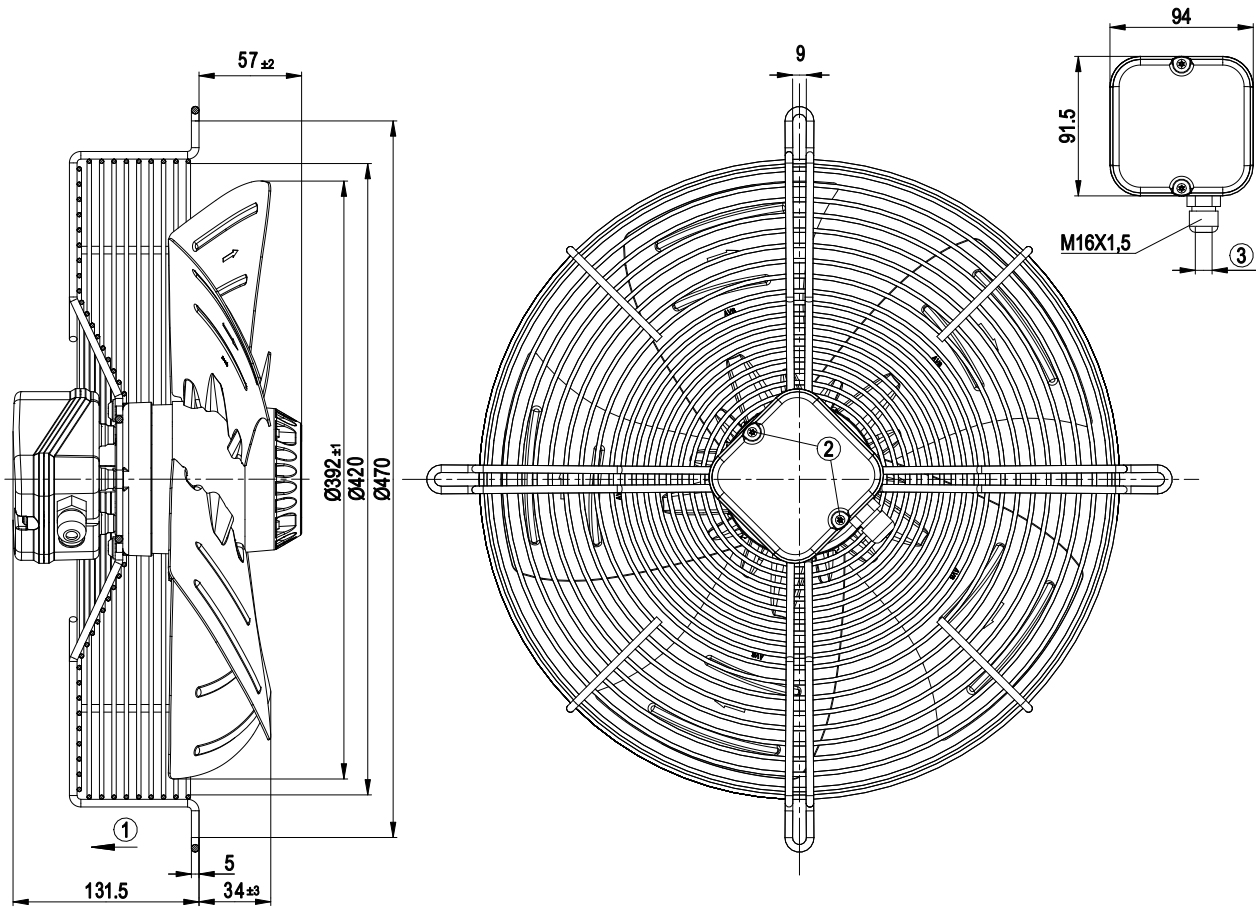

| | |
|---|--|
| 1 | Direction of air flow "V" |
| 2 | Tightening torque 0.5 ± 0.1 Nm |
| 3 | Cable diameter max. 7.5 mm, tightening torque 1.3 ± 0.2 Nm |

AC axial fan

sickle-shaped blades (S series)
with guard grille for short nozzle

Connection diagram

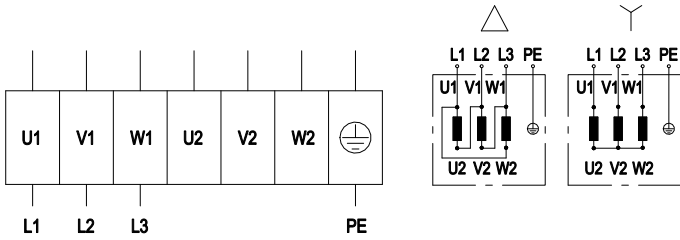

| | | | | | |
|----|-------------------|----|-----------------|----|------------------|
| | Three-phase motor | Y | Star connection | Δ | Delta connection |
| L1 | = U1 = blue | L2 | = V1 = black | L3 | = W1 = brown |
| U2 | = white | V2 | = green | W2 | = yellow |
| PE | PE (green/yellow) | | | | |

AC axial fan

sickle-shaped blades (S series)
with guard grille for short nozzle

Curves: Air performance 50 Hz

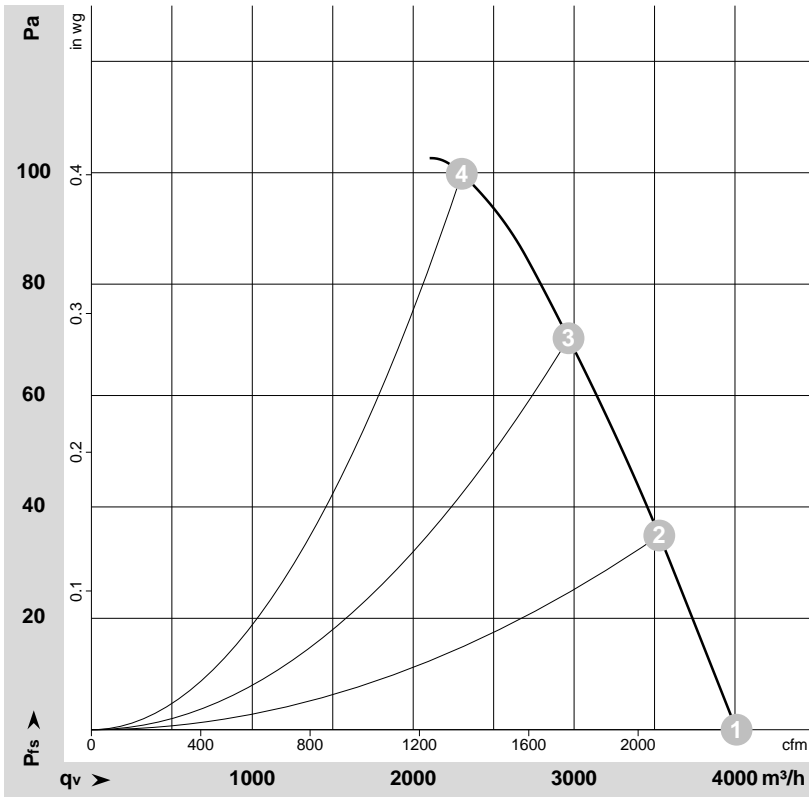

Measured values

| | Wired | U | f | n | P _e | I | qv | p _{fs} | qv | p _{fs} |
|---|-------|-----|----|-------------------|----------------|------|-------------------|-----------------|------|-----------------|
| | | V | Hz | min ⁻¹ | W | A | m ³ /h | Pa | CFM | inH2O |
| 1 | Y | 400 | 50 | 1450 | 135 | 0.44 | 4010 | 0 | 2360 | 0.00 |
| 2 | Y | 400 | 50 | 1435 | 161 | 0.47 | 3530 | 35 | 2080 | 0.14 |
| 3 | Y | 400 | 50 | 1420 | 183 | 0.49 | 2965 | 70 | 1745 | 0.28 |
| 4 | Y | 400 | 50 | 1410 | 204 | 0.50 | 2300 | 100 | 1355 | 0.40 |

Wired = Wiring · U = Power supply · f = Frequency · n = Speed (rpm) · P_e = Power consumption · I = Current draw · qv = Air flow · p_{fs} = Pressure increase