

8300101341  
VBS0630STTPZ

# EC centrifugal fan - RadiCal

backward-curved, single-intake

8300101341 ebmpapst Datasheet  
sales@fansco.com  
www.fansco.com

## Nominal data

Item	8300101341	
Motor	E15031-85	
Phase		3~
Nominal voltage	VAC	400
Nominal voltage range	VAC	380 .. 480
Frequency	Hz	50/60
Method of obtaining data		ml
Status		prelim.
Speed (rpm)	min <sup>-1</sup>	1420-1475
Power consumption	W	3700
Current draw	A	5.7
Min. ambient temperature	°C	-40
Max. ambient temperature	°C	45

ml = Max. load · me = Max. efficiency · fa = Free air · cs = Customer specification · ce = Customer equipment  
Subject to change

## Data according to Commission Regulation (EU) 327/2011 (prEN 17166)

		Actual	Req. 2015			
01 Overall efficiency $\eta_{es}$	%	71.4	57.5	09 Power consumption $P_{ed}$	kW	3.7
02 Measurement category		A		09 Air flow $q_v$	m <sup>3</sup> /h	12720
03 Efficiency category		Static		09 Pressure increase $p_{fs}$	Pa	715
04 Efficiency grade N		75.9	62	10 Speed (rpm) n	min <sup>-1</sup>	1425
05 Variable speed drive		Yes		11 Specific ratio <sup>*</sup>		1.01

Data obtained at optimum efficiency level.

<sup>\*</sup> Specific ratio =  $1 + p_{fs} / 100\,000\text{ Pa}$

LU-230044

The efficiency values displayed for achieving conformity with the Ecodesign Regulation EU 327/2011 has been reached with defined air duct components (e.g. inlet rings).  
The dimensions must be requested from ebm-papst. If other air conduction geometries are used on the installation side, the ebm-papst evaluation loses its validity/the conformity must be confirmed again.  
The product does not fall within the scope of Regulation (EU) 2019/1781 due to the exception specified in Article 2 (2a) (motors completely integrated into a product).

8300101341  
VBS0630STTPZ

# EC centrifugal fan - RadiCal

backward-curved, single-intake

## Technical description

Weight	28.6 kg
Size	630 mm
Motor size	150
Rotor surface	Painted black
Electronics housing material	Die-cast aluminum
Impeller material	PP plastic
Number of blades	6
Direction of rotation	Clockwise, viewed toward rotor
Degree of protection	IP55
Insulation class	"F"
Moisture (F) / Environmental (H) protection class	H1
Ambient temperature note	Occasional start-up at temperatures between -40°C and -25°C is permitted. For continuous operation at ambient temperatures below -25°C (such as refrigeration applications), use must be made of a fan design with special low-temperature bearings.
Max. permitted ambient temp. for motor (transport/storage)	+80 °C
Min. permitted ambient temp. for motor (transport/storage)	-40 °C
Installation position	Shaft horizontal or rotor on bottom; rotor on top on request
Condensation drainage holes	On rotor side
Mode	S1
Motor bearing	Ball bearing
Technical features	<ul style="list-style-type: none"><li>- Operation and alarm display with LED</li><li>- External 15-50 VDC input (parameterization)</li><li>- Alarm relay</li><li>- Integrated PI controller</li><li>- Configurable inputs/outputs (I/O)</li><li>- MODBUS V6.3</li><li>- Motor current limitation</li><li>- RS-485 MODBUS-RTU</li><li>- Soft start</li><li>- Voltage output 3.3-24 VDC, Pmax = 800 mW</li><li>- Control interface with SELV potential safely disconnected from the mains</li><li>- Thermal overload protection for electronics/motor</li><li>- Line undervoltage / phase failure detection</li></ul>
EMC immunity to interference	According to EN 61000-6-2 (industrial environment)
EMC interference emission	According to EN 61000-6-3 (household environment), except EN 61000-3-2 for professionally used equipment with a total rated power greater than 1 kW
Touch current according to IEC 60990 (measuring circuit Fig. 4, TN system)	<= 3.5 mA
Electrical hookup	Terminal box
Protection class assignment	I; If a protective earth is connected by the customer This component for installation may have several local protection classes. This information relates to this component's basic design. The final protection class is based on the component's intended installation and connection.
Conformity with standards	EN 61800-5-1; CE; UKCA
Approval	CSA C22.2 No. 77 + CAN/CSA-E60730-1; EAC; UL 1004-7 + 60730-1

8300101341  
VBS0630STTPZ

# EC centrifugal fan - RadiCal

backward-curved, single-intake

## Product drawing

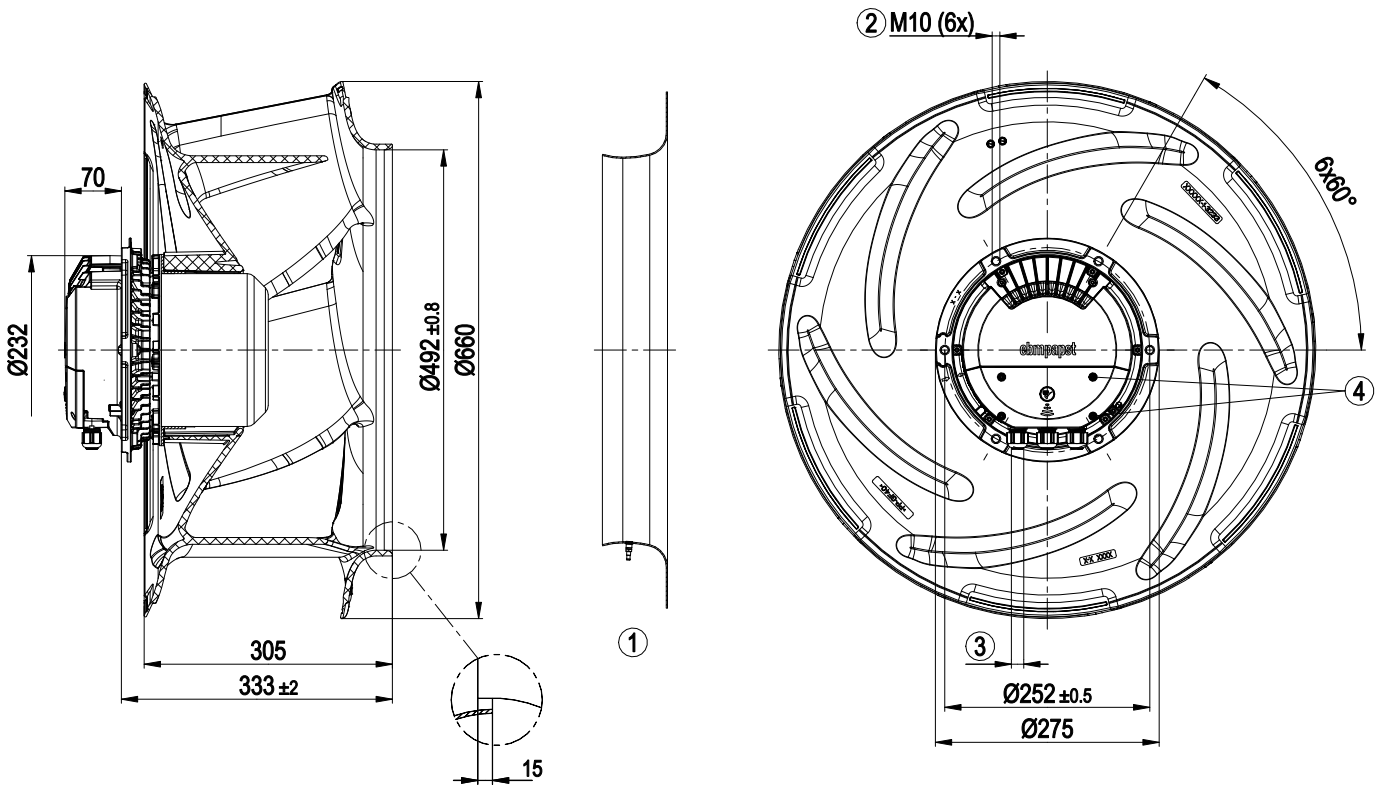

1	Accessory part: Inlet ring 63355-2-4013 with pressure tap (k-factor 545) not included in scope of delivery
2	Max. clearance for screw 20 mm
3	Cable diameter min. 4 mm, max. 10 mm, tightening torque $4 \pm 0.6$ Nm (The tightening torque is designed for PVC cables. If the cable materials are different, the tightening torque may have to be adjusted)
4	Tightening torque $1.5 \pm 0.2$ Nm

8300101341  
VBS0630STTPZ

# EC centrifugal fan - RadiCal

backward-curved, single-intake

## Accessory part

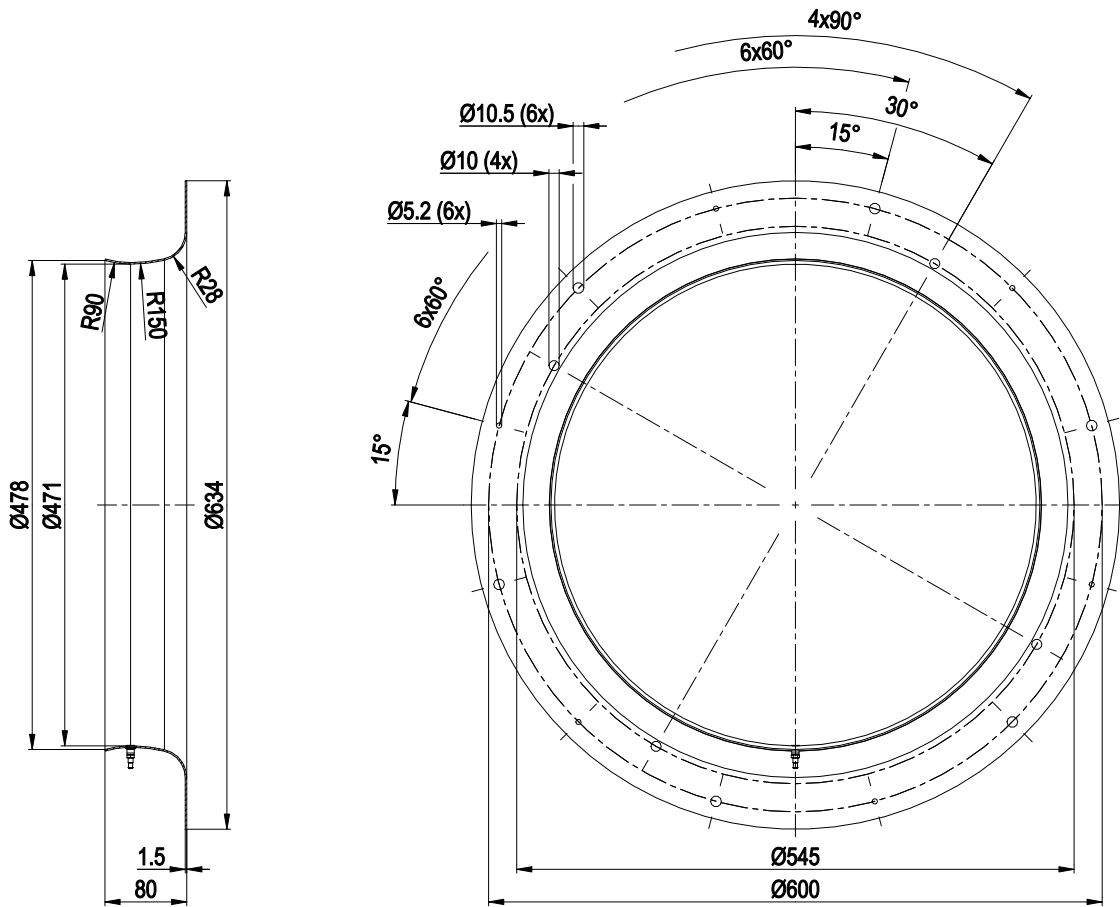

Inlet ring 63355-2-4013 with pressure tap (k-factor 545)

# EC centrifugal fan - RadiCal

backward-curved, single-intake

## Connection diagram

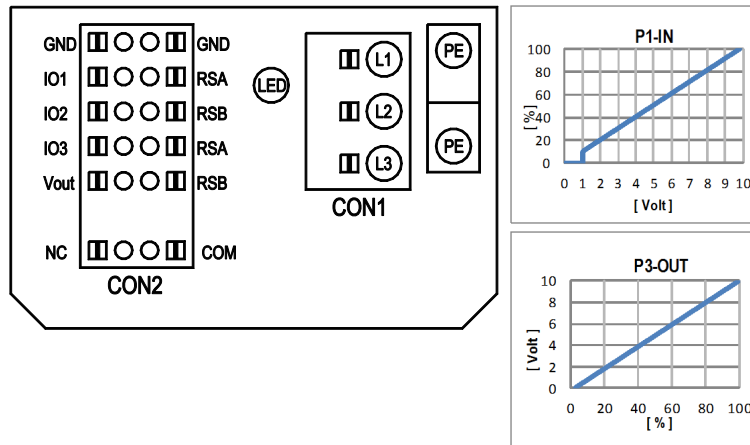

No.	Conn.	Designation	Function/assignment
	CON1	L1, L2, L3	Power supply, phase, see nameplate for voltage range
	PE	PE	Protective earth
	CON2	RSA	RS485 interface for MODBUS, RSA; SELV
	CON2	RSB	RS485 interface for MODBUS, RSB; SELV
	CON2	GND	Reference ground for control interface, SELV
	CON2	IO1	Function parameterizable (see "Optional interface functions" table) Factory setting: Digital input - high active, function: Disable input, SELV - inactive: Pin open or applied voltage < 1.5 VDC - active: applied voltage 3.5-50 VDC Reset function: Triggering of error reset on change of state from "enabled" to "disabled"
	CON2	IO2	Function parameterizable (see "Optional interface functions" table) Factory setting: Analog input 0-10 V / PWM, Ri=100 kΩ, function: Set value Characteristic curve parameterizable (see input characteristic curve P1-IN), SELV
	CON2	IO3	Function parameterizable (see "Optional interface functions" table) Factory setting: Analog output 0-10 V, max. 5 mA, function: Fan modulation level Characteristic curve parameterizable (see output characteristic curve P3-OUT), SELV
	CON2	Vout	Voltage output 3.3-24 VDC ±5%, Pmax=800 mW, voltage parameterizable Factory setting: 10 VDC short-circuit-proof, supply for external devices, SELV alternatively: 15-50 VDC input for parameterization via MODBUS without line voltage
	CON2	COM	Status relay, floating status contact, common connection, contact rating 250 VAC / 2 A (AC1) / min. 10 mA, reinforced insulation on supply side and on control interface side
	CON2	NC	Status relay, floating status contact, break for failure
		LED	green: status = good, ready for operation orange: status = warning red: status = failure
		P1-IN	Input characteristic curve
		P3-OUT	Output characteristic curve

## Terminal/plug assignment

CON2	configurable IO mode	electrical specification	configurable IO functions: normal / inverse	INPUT		OUTPUT												
				source: set value	source: sensor value	switch: parameter set: #1 / #2	switch: control function: heating (pos.) / cooling (neg.)	switch: direction of rotation: cw / ccw	switch: set value source	switch: fan enable / disable	signal: tach out	signal: diagnostics out (selected directly via IO mode)	signal: fan modulation level %	signal: actual speed	signal: system modulation level %	signal: remote control output 0-10V	pulse input for auto-addressing	pulse output for auto-addressing
IO1	○ Din1 (active high): digital input	active: applied voltage 3.5-50VDC, SELV not active: pin open or applied voltage < 1.5VDC	D158 [0]	○	○	○	○	○	○	○	○	○	○	○	○	○	○	○
	○ Ain1 0-10V/PWM: analog input	RI = 100k, characteristic curve parameterizable, f <sub>PWM</sub> = 1k..10kHz, SELV	D158 [2]	○	○	○	○	○	○	○	○	○	○	○	○	○	○	○
	○ Tach out (open collector output)	U <sub>max</sub> = 50VDC, I <sub>max</sub> = 20mA, SELV	D158 [5]	○	○	○	○	○	○	○	○	○	○	○	○	○	○	○
	○ Diagnostics out (open collector output)	U <sub>max</sub> = 50VDC, I <sub>max</sub> = 20mA, SELV	D158 [6]	○	○	○	○	○	○	○	○	○	○	○	○	○	○	○
	○ Din2 (active high): digital input	active: applied voltage 3.5-50VDC, SELV not active: pin open or applied voltage < 1.5VDC	D159 [0]	○	○	○	○	○	○	○	○	○	○	○	○	○	○	○
	○ Ain2 0-10V/PWM: analog input	RI = 100k, characteristic curve parameterizable, f <sub>PWM</sub> = 1k..10kHz, SELV	D159 [2]	○	○	○	○	○	○	○	○	○	○	○	○	○	○	○
IO2	○ Ain2 4-20mA: analog input	RI = 125R, characteristic curve parameterizable, SELV	D159 [3]	○	○	○	○	○	○	○	○	○	○	○	○	○	○	○
	○ Din3 (active high): digital input	active: applied voltage 3.5-50VDC, SELV not active: pin open or applied voltage < 1.5VDC	D15A [0]	○	○	○	○	○	○	○	○	○	○	○	○	○	○	○
	○ Din3 (active low): digital input	active: applied voltage < 1.5VDC, SELV not active: pin open or applied voltage 3.5-50VDC	D15A [1]	○	○	○	○	○	○	○	○	○	○	○	○	○	○	○
	○ PWMIn3: digital input, idle level high	PWM = 40Hz - 10kHz, characteristics parameterizable active: pin open or applied voltage 3.5-50VDC not active: applied voltage < 1.5VDC, SELV	D15A [7]	○	○	○	○	○	○	○	○	○	○	○	○	○	○	○
IO3	○ PWMIn3: digital input, idle level low	active: applied voltage 3.5-50VDC not active: pin open or applied voltage < 1.5VDC, SELV	D15A [8]	○	○	○	○	○	○	○	○	○	○	○	○	○	○	○
	○ Aout3 0-10V: analog output	function parameterizable, max. 5mA max output frequency 300Hz SELV	D15A [4]	○	○	○	○	○	○	○	○	○	○	○	○	○	○	○
	○ Tacho out (pulses), analog output	0-10V max. 5mA max output frequency 300Hz SELV	D15A [5]	○	○	○	○	○	○	○	○	○	○	○	○	○	○	○
RSA RSB	○ Diagnostics out (pulses)	0-10V max. 5mA max output frequency 300Hz, SELV	D15A [6]	○	○	○	○	○	○	○	○	○	○	○	○	○	○	○
	RS485 bus connection,	MODBUS RTU, specification V6.3, SELV		○	○	○	○	○	○	○	○	○	○	○	○	○	○	○
Vout	voltage output	voltage parameterizable 3.3...24VDC +/- 5%, P <sub>max</sub> =800mW, short-circuit-proof, supply for external devices, SELV	D16E [...]	○	○	○	○	○	○	○	○	○	○	○	○	○	○	○
	alternatively: Input auxiliary power supply/for parameterization via RS485/MODBUS RTU without line voltage	15...50VDC		○	○	○	○	○	○	○	○	○	○	○	○	○	○	○

○ configurable option

For further information and additional functions see EC Control Software: Fan-Set-App. or MODBUS Parameter Specification V6.3

## Curves: Air performance 50 Hz

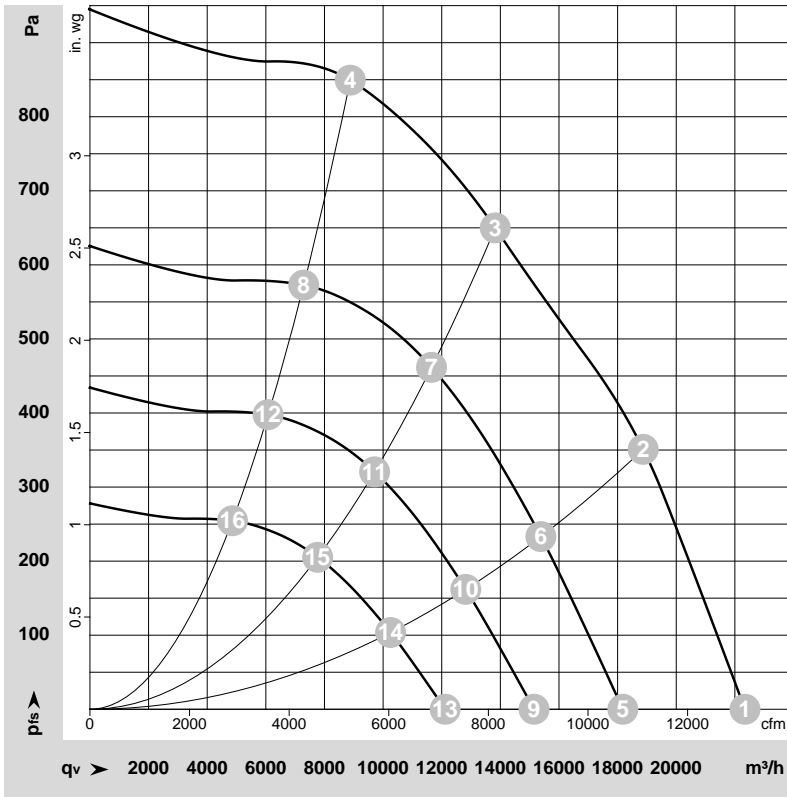

$\rho = 1.15 \text{ kg/m}^3 \pm 2 \%$

Measurement: LU-230044-1  
Date: 2026-06-07  
Nozzle: 63350-2-4013

Air performance measured according to ISO 5801 installation category A. For detailed information on the measurement setup, contact ebmpapst. Intake sound level: Sound power level according to ISO 13347 / sound pressure level measured at 1 m distance from fan axis. The values given are valid under the specified measuring conditions and may vary due to conditions of installation. For deviations from the standard configuration, the parameters have to be checked on the installed unit.

## Measured values

	Wired	U	f	n	P <sub>e</sub>	I	LpA <sub>in</sub>	LwA <sub>in</sub>	LwA <sub>out</sub>	LwA	q <sub>v</sub>	P <sub>fs</sub>	q <sub>v</sub>	P <sub>fs</sub>
		V	Hz	min <sup>-1</sup>	W	A	dB(A)	dB(A)	dB(A)	dB	m <sup>3</sup> /h	Pa	cfm	in. wg
1	3~	400	50	1475	2493	3.87	82	90	93	95	22345	0	13150	0.00
2	3~	400	50	1475	3585	5.49	80	86	89	91	18875	350	11110	1.41
3	3~	400	50	1420	3700	5.70	72	80	84	86	13825	650	8140	2.61
4	3~	400	50	1460	3629	5.55	76	84	88	89	8880	850	5225	3.41
5	3~	400	50	1200	1342	2.08	77	85	88	90	18180	0	10700	0.00
6	3~	400	50	1200	1925	2.95	75	81	84	86	15385	234	9055	0.94
7	3~	400	50	1200	2216	3.38	68	76	80	81	11650	462	6860	1.85
8	3~	400	50	1200	2011	3.07	71	79	83	84	7290	573	4290	2.30
9	3~	400	50	1000	777	1.21	72	81	83	85	15150	0	8915	0.00
10	3~	400	50	1000	1114	1.71	71	77	79	81	12820	163	7545	0.65
11	3~	400	50	1000	1282	1.96	63	71	75	77	9710	321	5715	1.29
12	3~	400	50	1000	1164	1.78	67	74	78	80	6075	398	3575	1.60
13	3~	400	50	800	398	0.62	67	75	77	79	12120	0	7135	0.00
14	3~	400	50	800	570	0.87	65	71	74	76	10255	104	6035	0.42
15	3~	400	50	800	657	1.00	58	66	70	71	7770	205	4570	0.82
16	3~	400	50	800	596	0.91	61	69	73	74	4860	255	2860	1.02

Wired = Wiring · U = Voltage · f = Frequency · n = Speed (rpm) · P<sub>e</sub> = Power consumption · I = Current draw · LpA<sub>in</sub> = Sound pressure level intake side · LwA<sub>in</sub> = Sound power level intake side  
LwA<sub>out</sub> = Sound power level outlet side · q<sub>v</sub> = Air flow · P<sub>fs</sub> = Pressure increase