

8300100589

VWA0910BTPPZ

# EC axial fan - AxiBlade

sickle-shaped blades (S series)

Fan housing with guard grille

8300100589 ebmpapst Datasheet

sales@fansco.com

www.fansco.com

Limited partnership · Headquarters Mulfingen

Amtsgericht (court of registration) Stuttgart · HRA 590344

General partner Elektrobau Mulfingen GmbH · Headquarters Mulfingen

Amtsgericht (court of registration) Stuttgart · HRB 590142

## Nominal data

Item	8300100589	
Motor	E15031-85	

Phase		3~
Nominal voltage	VAC	400
Nominal voltage range	VAC	380 .. 480
Frequency	Hz	50/60

Method of obtaining data		ml
Speed (rpm)	min <sup>-1</sup>	980
Power consumption	W	2550
Current draw	A	3.9
Max. back pressure	Pa	220
Max. back pressure	in. wg	0.88
Min. ambient temperature	°C	-40
Max. ambient temperature	°C	60

ml = Max. load · me = Max. efficiency · fa = Free air · cs = Customer specification · ce = Customer equipment  
Subject to change

## Data according to Commission Regulation (EU) 327/2011 (prEN 17166)

		Actual	Req. 2015			
01 Overall efficiency $\eta_{es}$	%	53.2	36.1	09 Power consumption $P_{ed}$	kW	2.38
02 Measurement category		A		09 Air flow $q_v$	m <sup>3</sup> /h	23685
03 Efficiency category		Static		09 Pressure increase $p_{fs}$	Pa	182
04 Efficiency grade N		57.1	40	10 Speed (rpm) n	min <sup>-1</sup>	980
05 Variable speed drive		Yes		11 Specific ratio*		1.00

Data obtained at optimum efficiency level.

\* Specific ratio =  $1 + p_{fs} / 100\,000\text{ Pa}$

LU-184391

The efficiency values displayed for achieving conformity with the Ecodesign Regulation EU 327/2011 has been reached with defined air duct components (e.g. inlet rings).  
The dimensions must be requested from ebm-papst. If other air conduction geometries are used on the installation side, the ebm-papst evaluation loses its validity/the conformity must be confirmed again.  
The product does not fall within the scope of Regulation (EU) 2019/1781 due to the exception specified in Article 2 (2a) (motors completely integrated into a product).



8300100589

VWA0910BTTPZ

# EC axial fan - AxiBlade

sickle-shaped blades (S series)

Fan housing with guard grille

## Technical description

Weight	50.4 kg
Size	910 mm
Motor size	150
Rotor surface	Painted black
Electronics housing material	Die-cast aluminum, painted gray
Impeller material	PP plastic
Fan housing material	Sheet steel, galvanized and coated with black plastic (RAL 9005)
Guard grille material	Steel, coated with black plastic (RAL 9005)
Number of blades	5
Blade pitch	0°
Airflow direction	V
Direction of rotation	Clockwise, viewed toward rotor
Degree of protection	IP55
Insulation class	"F"
Moisture (F) / Environmental (H) protection class	H2
Ambient temperature note	Occasional start-up at temperatures between -40°C and -25°C is permitted. For continuous operation at ambient temperatures below -25°C (such as refrigeration applications), use must be made of a fan design with special low-temperature bearings.
Max. permitted ambient temp. for motor (transport/storage)	+80 °C
Min. permitted ambient temp. for motor (transport/storage)	-40 °C
Installation position	Shaft horizontal or rotor on bottom; rotor on top on request
Condensation drainage holes	On rotor side
Mode	S1
Motor bearing	Ball bearing
Technical features	<ul style="list-style-type: none"> <li>- Operation and alarm display with LED</li> <li>- External 15-50 VDC input (parameterization)</li> <li>- Alarm relay</li> <li>- Integrated PI controller</li> <li>- Configurable inputs/outputs (I/O)</li> <li>- MODBUS V6.3</li> <li>- Motor current limitation</li> <li>- RS-485 MODBUS-RTU</li> <li>- Soft start</li> <li>- Voltage output 3.3-24 VDC, Pmax = 800 mW</li> <li>- Control interface with SELV potential safely disconnected from the mains</li> <li>- Thermal overload protection for electronics/motor</li> <li>- Line undervoltage / phase failure detection</li> </ul>
EMC immunity to interference	According to EN 61000-6-2 (industrial environment)
EMC interference emission	According to EN 61000-6-3 (household environment), except EN 61000-3-2 for professionally used equipment with a total rated power greater than 1 kW
Touch current according to IEC 60990 (measuring circuit Fig. 4, TN system)	<= 3.5 mA
Electrical hookup	Terminal box
Motor protection	Electronic motor protection



8300100589

VWA0910BTPZ

# EC axial fan - AxiBlade

sickle-shaped blades (S series)

Fan housing with guard grille

<b>Protection class assignment</b>	I; If a protective earth is connected by the customer This component for installation may have several local protection classes. This information relates to this component's basic design. The final protection class is based on the component's intended installation and connection.
<b>Conformity with standards</b>	EN 61800-5-1; CE; UKCA
<b>Approval</b>	CSA C22.2 No. 77 + CAN/CSA-E60730-1; EAC; UL 1004-7 + 60730-1



8300100589

VWA0910BTPZ

# EC axial fan - AxiBlade

sickle-shaped blades (S series)

Fan housing with guard grille

## Product drawing

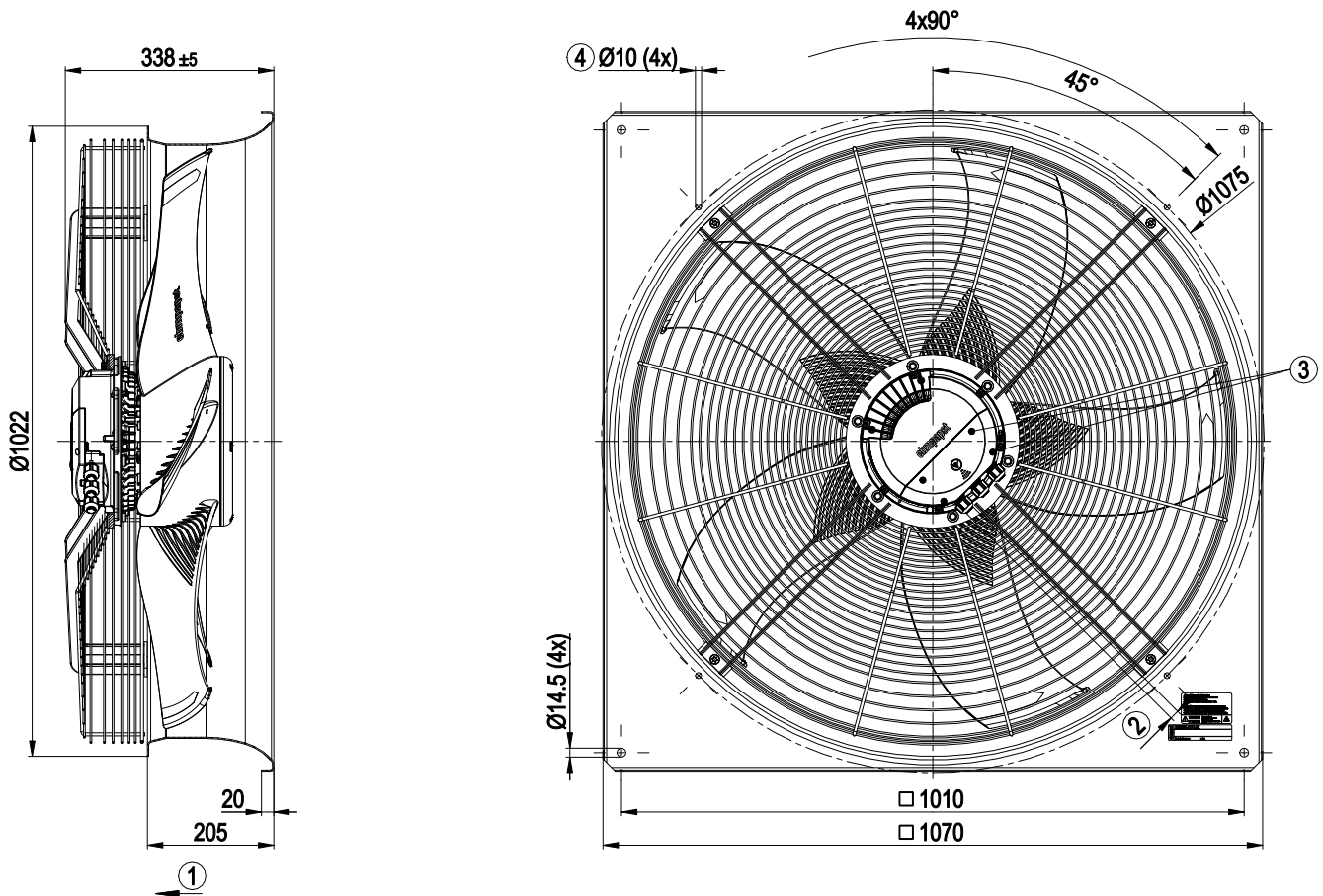

1	Airflow direction "V"
2	Cable diameter min. 4 mm, max. 10 mm, tightening torque $4 \pm 0.6$ Nm (The tightening torque is designed for PVC cables. If the cable materials are different, the tightening torque may have to be adjusted)
3	Tightening torque $1.5 \pm 0.2$ Nm
4	Attachment holes for FlowGrid 91000-2-2957 (not included in scope of delivery)



# EC axial fan - AxiBlade

sickle-shaped blades (S series)

Fan housing with guard grille

## Connection diagram

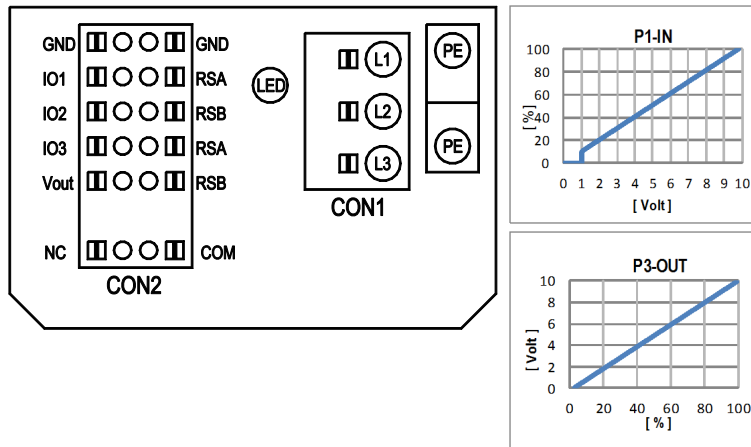

No.	Conn.	Designation	Function/assignment
	CON1	L1, L2, L3	Power supply, phase, see nameplate for voltage range
	PE	PE	Protective earth
	CON2	RSA	RS485 interface for MODBUS, RSA; SELV
	CON2	RSB	RS485 interface for MODBUS, RSB; SELV
	CON2	GND	Reference ground for control interface, SELV
	CON2	IO1	Function parameterizable (see "Optional interface functions" table) Factory setting: Digital input - high active, function: Disable input, SELV - inactive: Pin open or applied voltage < 1.5 VDC - active: applied voltage 3.5-50 VDC Reset function: Triggering of error reset on change of state from "enabled" to "disabled"
	CON2	IO2	Function parameterizable (see "Optional interface functions" table) Factory setting: Analog input 0-10 V/PWM, Ri=100 kΩ, function: Set value Characteristic curve parameterizable (see input characteristic curve P1-IN), SELV
	CON2	IO3	Function parameterizable (see "Optional interface functions" table) Factory setting: Analog output 0-10 V, max. 5 mA, function: Actual speed Characteristic curve parametrizable (see output characteristic curve P3-OUT), SELV
	CON2	Vout	Voltage output 3.3-24 VDC ±5%, Pmax=800 mW, voltage parameterizable Factory setting: 10 VDC short-circuit-proof, supply for external devices, SELV alternatively: 15-50 VDC input for parameterization via MODBUS without line voltage
	CON2	COM	Status relay, floating status contact, common connection, contact rating 250 VAC / 2 A (AC1) / min. 10 mA, reinforced insulation on supply side and on control interface side
	CON2	NC	Status relay, floating status contact, break for failure
		LED	green: status = good, ready for operation orange: status = warning red: status = failure
		P1-IN	Input characteristic curve
		P3-OUT	Output characteristic curve



# EC axial fan - AxiBlade

sickle-shaped blades (S series)

Fan housing with guard grille

## Terminal/plug assignment

CON2	configurable IO mode	electrical specification	configurable IO functions: normal / inverse	MODBUS Register for IO mode configuration	
				source: set value	switch: fan enable / disable
IO1	○ Din1 (active high), digital input	active: applied voltage 3.5-50VDC, SELV not active: pin open or applied voltage < 1.5VDC		○	D158 [0]
	○ Ain1 0-10V/PWM: analog input	RI = 100k, characteristic curve parameterizable, f <sub>PWM</sub> = 1k..10kHz, SELV		○	D158 [2]
	○ Tach out (open collector output)	U <sub>max</sub> = 50VDC, I <sub>max</sub> = 20mA, SELV		○	D158 [5]
	○ Diagnostics out (open collector output)	U <sub>max</sub> = 50VDC, I <sub>max</sub> = 20mA, SELV		○	D158 [6]
IO2	○ Din2 (active high), digital input	active: applied voltage 3.5-50VDC, SELV not active: pin open or applied voltage < 1.5VDC		○	D159 [0]
	○ Ain2 0-10V/PWM: analog input	RI = 100k, characteristic curve parameterizable, f <sub>PWM</sub> = 1k..10kHz, SELV		○	D159 [2]
	○ Ain2 4-20mA: analog input	RI = 125R, characteristic curve parameterizable, SELV		○	D159 [3]
	○ Din3 (active high), digital input	active: applied voltage 3.5-50VDC, SELV not active: pin open or applied voltage < 1.5VDC		○	D15A [0]
IO3	○ Din3 (active low), digital input	active: applied voltage < 1.5VDC, SELV not active: pin open or applied voltage 3.5-50VDC		○	D15A [1]
	○ PWMIn3: digital input, idle level high	PWM = 40Hz - 10kHz, characteristics parameterizable		○	D15A [7]
	○ PWMIn3: digital input, idle level low	active: pin open or applied voltage 3.5-50VDC not active: applied voltage < 1.5VDC, SELV		○	D15A [8]
	○ Aout3 0-10V: analog output	function parameterizable, max. 5mA max output frequency 300Hz, SELV		○	D15A [4]
RSA	○ Tacho out (pulses), analog output	0-10V/max. 5mA max output frequency 300Hz, SELV		○	D15A [5]
	○ Diagnostics out (pulses)	0-10V/max. 5mA max output frequency 300Hz, SELV		○	D15A [6]
	○ Diagnostics out (pulses)	MODBUS RTU, specification V6.3, SELV		○	
RSB	RS485 bus connection,				
Vout	voltage output	voltage parameterizable 3.3..24VDC +/- 5%, P <sub>max</sub> =800mW, short-circuit-proof, supply for external devices, SELV			D16E [..]
	alternatively: Input auxiliary power supply for parameterization via RS485/MODBUS RTU without line voltage	15..50VDC			

○ configurable option

For further information and additional functions see EC Control Software, Fan-Set-App, or MODBUS Parameter Specification V6.3



8300100589

VWA0910BTPZ

# EC axial fan - AxiBlade

sickle-shaped blades (S series)

Fan housing with guard grille

## Curves: Air performance 50 Hz

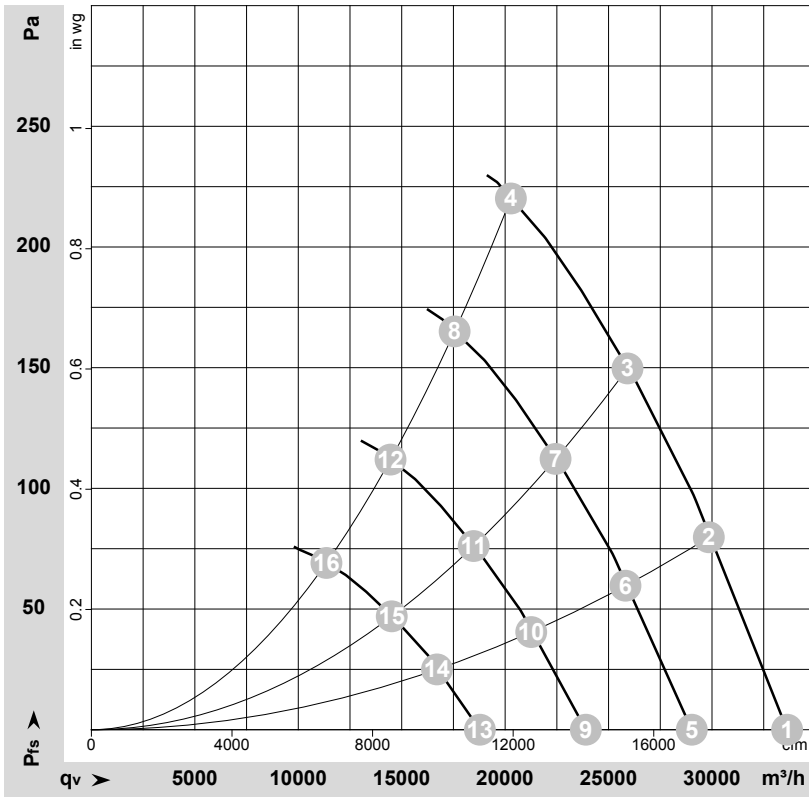

$\rho = 1.15 \text{ kg/m}^3 \pm 2 \%$

Measurement: LU-184391-1

Air performance measured according to ISO 5801 installation category A. For detailed information on the measurement setup, contact ebmpapst. Intake sound level: Sound power level according to ISO 13347 / sound pressure level measured at 1 m distance from fan axis. The values given are valid under the specified measuring conditions and may vary due to conditions of installation. For deviations from the standard configuration, the parameters have to be checked on the installed unit.

## Measured values

	U	f	n	P <sub>e</sub>	I	LpA <sub>in</sub>	LwA <sub>in</sub>	LwA <sub>out</sub>	q <sub>v</sub>	P <sub>fs</sub>	q <sub>v</sub>	P <sub>fs</sub>
	V	Hz	min <sup>-1</sup>	W	A	dB(A)	dB(A)	dB(A)	m <sup>3</sup> /h	Pa	cfm	in. wg
1	400	50	980	1563	2.50	72	79	80	33630	0	19795	0.00
2	400	50	980	1938	3.04	69	76	77	29845	80	17565	0.32
3	400	50	980	2245	3.49	70	77	77	25915	150	15255	0.60
4	400	50	980	2550	3.90	75	82	82	20280	220	11935	0.88
5	400	50	850	1004	1.60	68	75	76	29025	0	17080	0.00
6	400	50	850	1255	1.97	66	73	74	25820	61	15195	0.24
7	400	50	850	1457	2.27	67	73	74	22440	112	13205	0.45
8	400	50	850	1663	2.57	72	78	79	17560	165	10335	0.66
9	400	50	700	561	0.90	63	70	71	23900	0	14070	0.00
10	400	50	700	701	1.10	61	68	69	21260	41	12515	0.16
11	400	50	700	814	1.27	62	68	69	18480	76	10875	0.31
12	400	50	700	929	1.44	67	74	74	14460	112	8510	0.45
13	400	50	550	272	0.43	57	64	65	18780	0	11055	0.00
14	400	50	550	340	0.53	55	62	63	16705	26	9835	0.10
15	400	50	550	395	0.61	56	62	63	14520	47	8545	0.19
16	400	50	550	451	0.70	61	67	68	11360	69	6685	0.28

U = Voltage · f = Frequency · n = Speed (rpm) · P<sub>e</sub> = Power consumption · I = Current draw · LpA<sub>in</sub> = Sound pressure level intake side · LwA<sub>in</sub> = Sound power level intake side  
LwA<sub>out</sub> = Sound power level outlet side · q<sub>v</sub> = Air flow · P<sub>fs</sub> = Pressure increase

