

8300100499
VWS0385XUPEZ

EC axial fan

with brushless DC motor
Automotive

8300100499 ebmpapst Datasheet
sales@fansco.com
www.fansco.com

Limited partnership · Headquarters Muldingen
Amtsgericht (court of registration) Stuttgart · HRA 590344
General partner Elektrobau Muldingen GmbH · Headquarters Muldingen
Amtsgericht (court of registration) Stuttgart · HRB 590142

Nominal data

Item	8300100499	
Motor	E08419-25	
Nominal voltage	VDC	26
Nominal voltage range	VDC	16 .. 32
Method of obtaining data		fa
Speed (rpm)	min ⁻¹	3300
Power consumption	W	525
Current draw	A	20
Min. ambient temperature	°C	-40
Max. ambient temperature	°C	70

ml = Max. load · me = Max. efficiency · fa = Free air · cs = Customer specification · ce = Customer equipment
Subject to change



8300100499

VWS0385XUPEZ

EC axial fan

with brushless DC motor

Automotive

Technical description

Weight	3.2 kg
Size	385 mm
Motor size	84
Blade material	PA plastic
Fan housing material	PA plastic
Number of blades	7
Airflow direction	V
Balancing grade according to DIN ISO 21940-11	G 10
Direction of rotation	Clockwise, viewed toward rotor
Degree of protection	Motor IP24 KM, electronics IP6K9K (mating connector installed)
Insulation class	"B"
Moisture (F) / Environmental (H) protection class	H4
Ambient temperature note	Occasional start-up at temperatures between -40°C and -25°C is permitted. For continuous operation at ambient temperatures below -25°C (such as refrigeration applications), use must be made of a fan design with special low-temperature bearings.
Max. permitted ambient temp. for motor (transport/storage)	+80 °C
Min. permitted ambient temp. for motor (transport/storage)	-40 °C
Installation position	Any
Condensation drainage holes	None, open rotor
Mode	S1
Motor bearing	Ball bearing
Life expectancy	40,000 h (depending on load profile and ambient conditions)
Technical features	<ul style="list-style-type: none"> - Error output (high-side switch) - Power limiter - Load dump (58 V) - Motor current limitation - Soft start - Control input 0-10 VDC / PWM - Temperature derating - Overvoltage detection - Thermal overload protection for electronics - Line undervoltage detection
Electrical hookup	Connector with cable; Standby current less than 500 µA
Motor protection	Reverse polarity and locked-rotor protection
With cable	Lateral
Approval	EAC



8300100499
VWS0385XUPEZ

EC axial fan

with brushless DC motor
Automotive

Product drawing

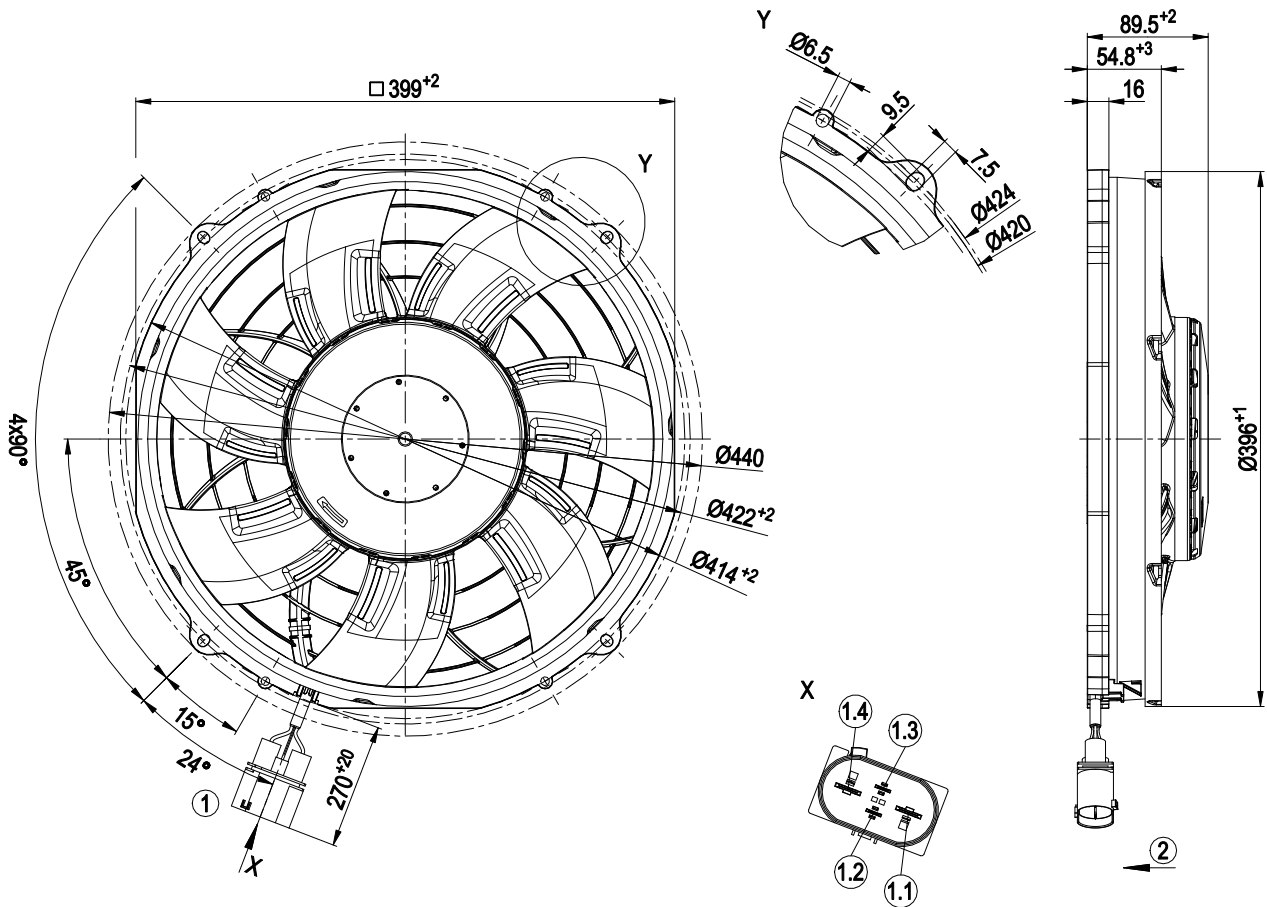

1	Cable FLRYW 2x 6.0 mm ² , 2x 1.0 mm ²
	4-pole connector housing Aptiv F353200, 2x flat plug FCI 60170261, 2x flat plug TE 964310-1, 2x seal FCI 60993308, 2x seal TE 1394511-1
1.1	+ UB
1.2	Diagnostic output
1.3	PWM/LIN
1.4	GND
	4-pole mating connector Aptiv F004200, 2x flat plug FCI 60070261, 2x flat plug TE 927831-1, 2x seal FCI 60993308, 2x seal TE 1394511-1
2	Airflow direction "V"



Connection diagram

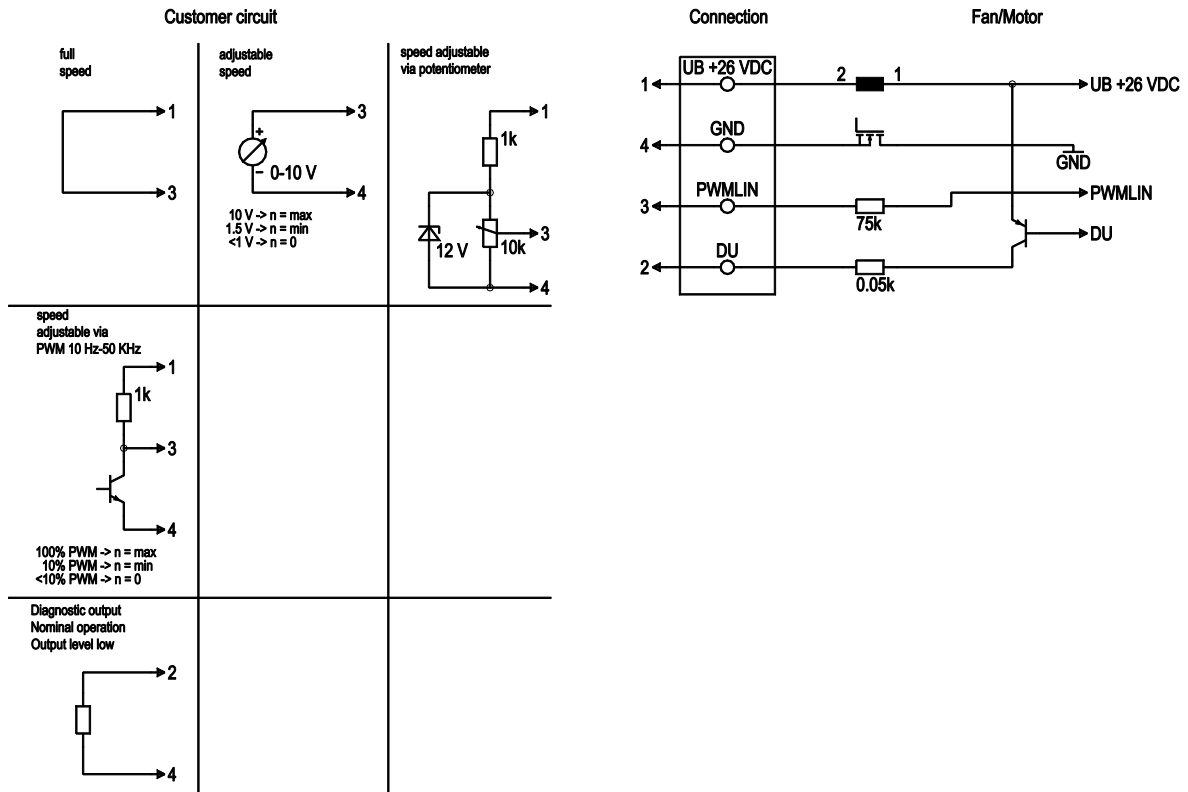

No.	Conn.	Designation	Function/assignment
1	UB +26 VDC	UB +26 VDC	Power supply 26 VDC
2	DU	DU	Diagnostic output
3	PWMLIN	PWMLIN	Analog voltage control input 0-10 V or PWM
4	GND	GND	Power supply GND, reference ground

Curves: Air performance

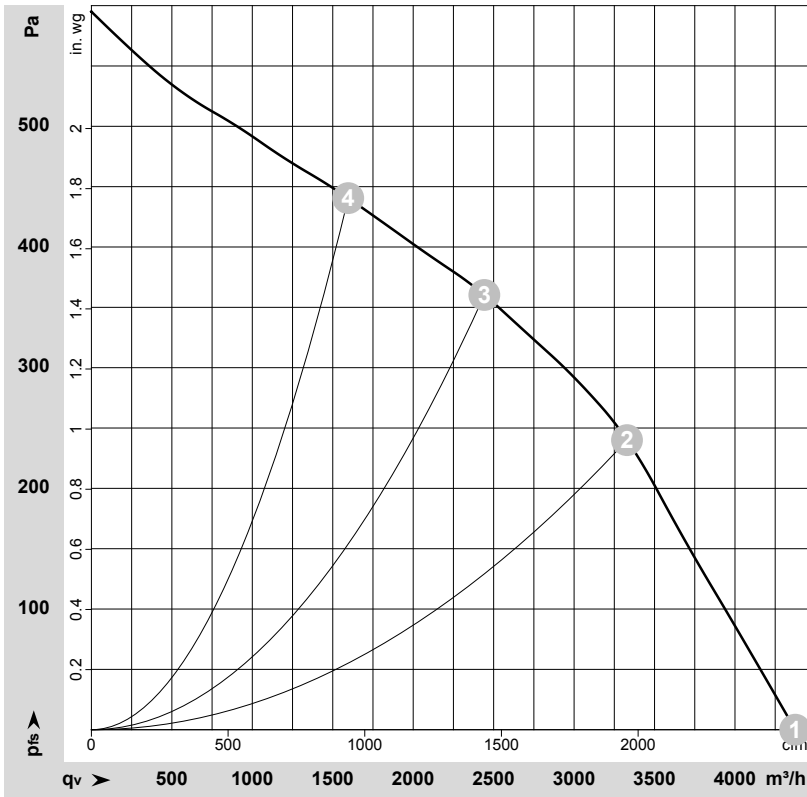

$\rho = 1.15 \text{ kg/m}^3 \pm 2 \%$

Measurement: LU-141959-1

Air performance measured according to ISO 5801 installation category A. For detailed information on the measurement setup, contact ebmpapst. Intake sound level: Sound power level according to ISO 13347 / sound pressure level measured at 1 m distance from fan axis. The values given are valid under the specified measuring conditions and may vary due to conditions of installation. For deviations from the standard configuration, the parameters have to be checked on the installed unit.

Measured values

	U	n	P _e	I	LpA _{in}	LwA _{in}	q _v	P _{fs}	q _v	P _{fs}
	V	min ⁻¹	W	A	dB(A)	dB(A)	m ³ /h	Pa	cfm	in. wg
1	26	3300	525	20.00	83	90	4375	0	2575	0.00
2	26	3170	618	23.80	81	88	3330	240	1960	0.96
3	26	3030	610	23.44	80	88	2440	360	1435	1.45
4	26	2895	613	23.56	82	89	1595	440	940	1.77

U = Voltage · n = Speed (rpm) · P_e = Power consumption · I = Current draw · LpA_{in} = Sound pressure level intake side · LwA_{in} = Sound power level intake side · q_v = Air flow
P_{fs} = Pressure increase

