

8300100465  
VBS0400CTPMS

# EC centrifugal fan - RadiPac

8300100465 ebmpapst Datasheet

sales@fansco.com

www.fansco.com

## Nominal data

Item	8300100465	
Motor	E08423-65	
Phase		3~
Nominal voltage	VAC	400
Nominal voltage range	VAC	380 .. 480
Frequency	Hz	50/60
Method of obtaining data		ml
Speed (rpm)	min <sup>-1</sup>	2480
Power consumption	W	1400
Current draw	A	2.2
Min. ambient temperature	°C	-40
Max. ambient temperature	°C	40

ml = Max. load · me = Max. efficiency · fa = Free air · cs = Customer specification · ce = Customer equipment  
Subject to change

## Data according to Commission Regulation (EU) 327/2011 (prEN 17166)

		Actual	Req. 2015			
01 Overall efficiency $\eta_{es}$	%	68.5	53	09 Power consumption $P_{ed}$	kW	1.37
02 Measurement category		A		09 Air flow $q_v$	m <sup>3</sup> /h	5035
03 Efficiency category		Static		09 Pressure increase $p_{fs}$	Pa	628
04 Efficiency grade N		77.5	62	10 Speed (rpm) n	min <sup>-1</sup>	2480
05 Variable speed drive		Yes		11 Specific ratio <sup>*</sup>		1.01

Data obtained at optimum efficiency level.

<sup>\*</sup> Specific ratio =  $1 + p_s / 100\,000\text{ Pa}$

LU-219895

The efficiency values displayed for achieving conformity with the Ecodesign Regulation EU 327/2011 has been reached with defined air duct components (e.g. inlet rings). The dimensions must be requested from ebm-papst. If other air conduction geometries are used on the installation side, the ebm-papst evaluation loses its validity/the conformity must be confirmed again. The product does not fall within the scope of Regulation (EU) 2019/1781 due to the exception specified in Article 2 (2a) (motors completely integrated into a product).

8300100465  
VBS0400CTPMS

# EC centrifugal fan - RadiPac

backward-curved, single-intake

## Technical description

Weight	7.16 kg
Size	400 mm
Motor size	84
Rotor surface	Painted black
Electronics housing material	Die-cast aluminum
Impeller material	PP plastic
Number of blades	5
Direction of rotation	Clockwise, viewed toward rotor
Degree of protection	IP55
Insulation class	"F"
Moisture (F) / Environmental (H) protection class	H1
Ambient temperature note	Occasional start-up at temperatures between -40°C and -25°C is permitted. For continuous operation at ambient temperatures below -25°C (such as refrigeration applications), use must be made of a fan design with special low-temperature bearings.
Max. permitted ambient temp. for motor (transport/storage)	+80 °C
Min. permitted ambient temp. for motor (transport/storage)	-40 °C
Installation position	Shaft horizontal or rotor on bottom; rotor on top on request
Condensation drainage holes	On rotor side
Mode	S1
Motor bearing	Ball bearing
Technical features	<ul style="list-style-type: none"><li>- Output 10 VDC, max. 10 mA</li><li>- Operation and alarm display</li><li>- External 24 V input (parameter setting)</li><li>- Alarm relay</li><li>- Integrated PID controller</li><li>- MODBUS V5.1</li><li>- Motor current limitation</li><li>- PFC, passive</li><li>- RS-485 MODBUS-RTU</li><li>- Soft start</li><li>- EEPROM write cycles: 100,000 maximum</li><li>- Control input 0-10 VDC / PWM</li><li>- Control interface with SELV potential safely disconnected from the mains</li><li>- Thermal overload protection for electronics/motor</li><li>- Line undervoltage / phase failure detection</li></ul>
EMC immunity to interference	According to EN 61000-6-2 (industrial environment)
EMC interference emission	According to EN 61000-6-3 (household environment), except EN 61000-3-2 for professionally used equipment with a total rated power greater than 1 kW
Touch current according to IEC 60990 (measuring circuit Fig. 4, TN system)	<= 3.5 mA
Motor protection	Thermal switch auto reset, internally connected
With cable	Lateral

8300100465  
VBS0400CTPMS

# EC centrifugal fan - RadiPac

backward-curved, single-intake

<b>Protection class assignment</b>	I; If a protective earth is connected by the customer This component for installation may have several local protection classes. This information relates to this component's basic design. The final protection class is based on the component's intended installation and connection.
<b>Conformity with standards</b>	EN 61800-5-1; UKCA; CE
<b>Approval</b>	CSA C22.2 No. 77 + CAN/CSA-E60730-1; EAC; UL 1004-7 + 60730-1

8300100465  
VBS0400CTPMS

# EC centrifugal fan - RadiPac

backward-curved, single-intake

## Product drawing

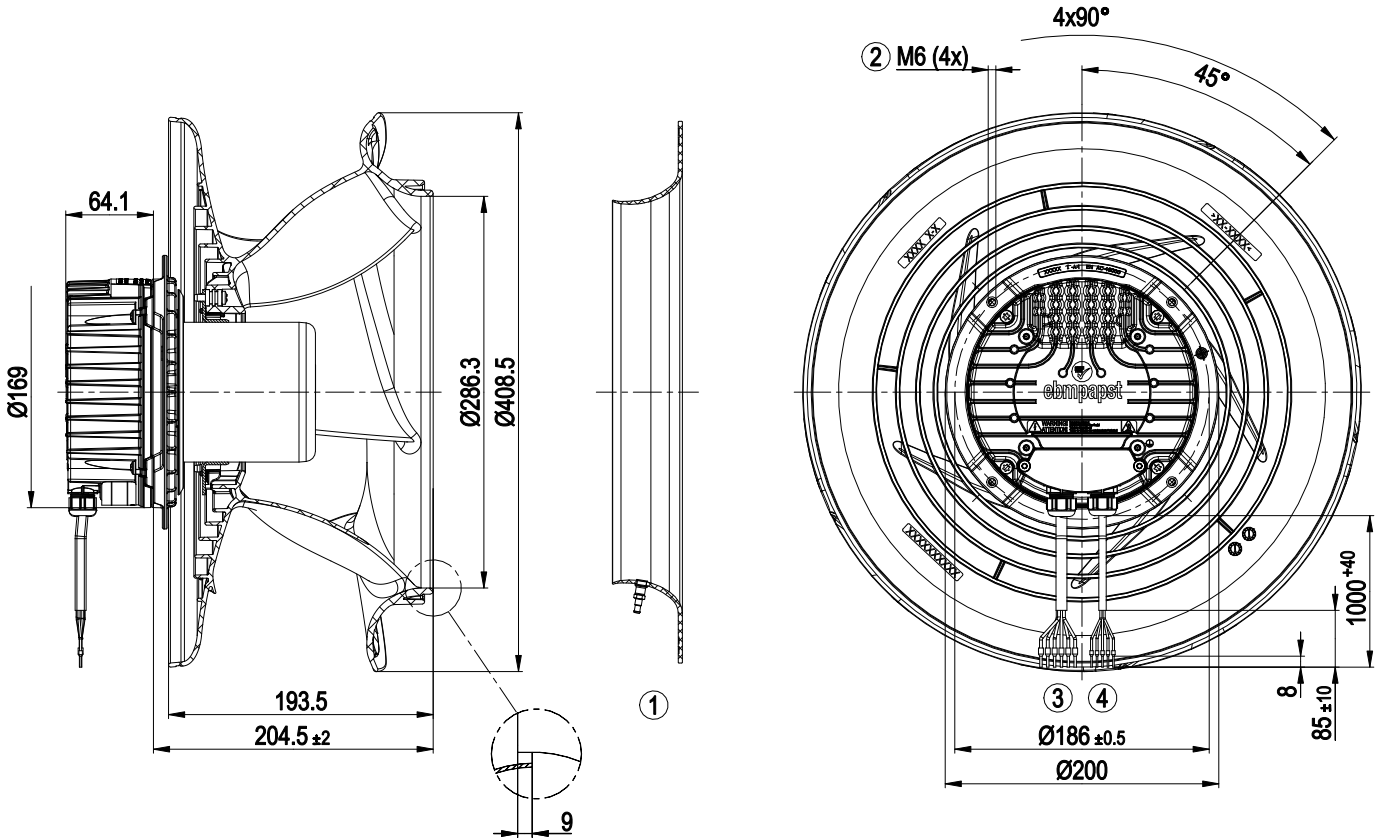

1	Accessory part: Inlet ring 8217102241 with pressure tap (k-factor: 190) (not included in scope of delivery)
2	Max. clearance for screw 16 mm
3	Cable PVC AWG18 6x wire-end ferrule
4	Cable PVC AWG22 5x wire-end ferrule

8300100465  
VBS0400CTPMS

# EC centrifugal fan - RadiPac

backward-curved, single-intake

## Accessory part

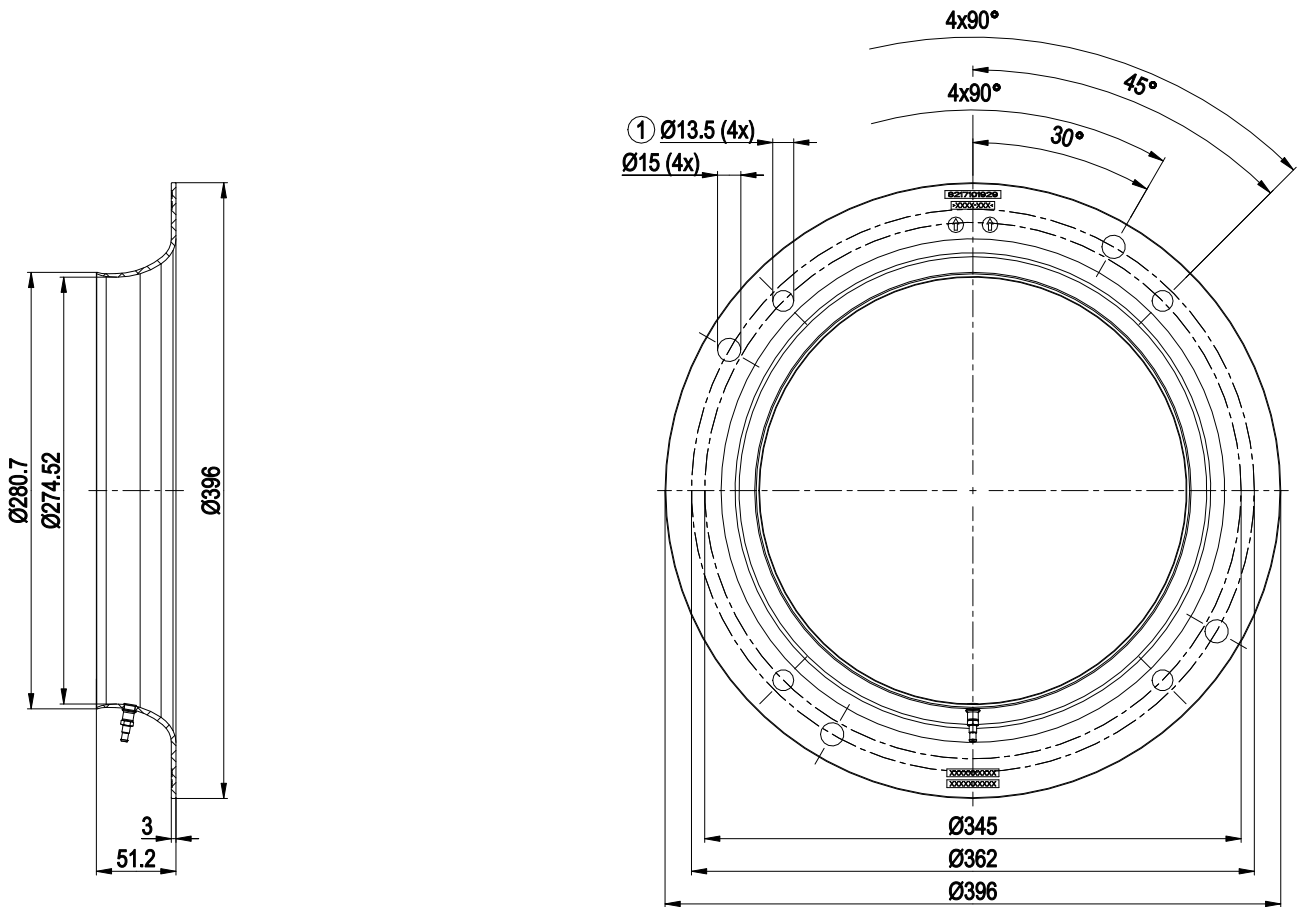

Inlet ring 8217102241 with pressure tap (k-factor: 190)

- |   |  |
|---|--|
| 1 | Fastening holes for FlowGrid 00400-2-2957 (not included in scope of delivery) are provided and must be subsequently opened as required |
|---|--|

## Connection diagram

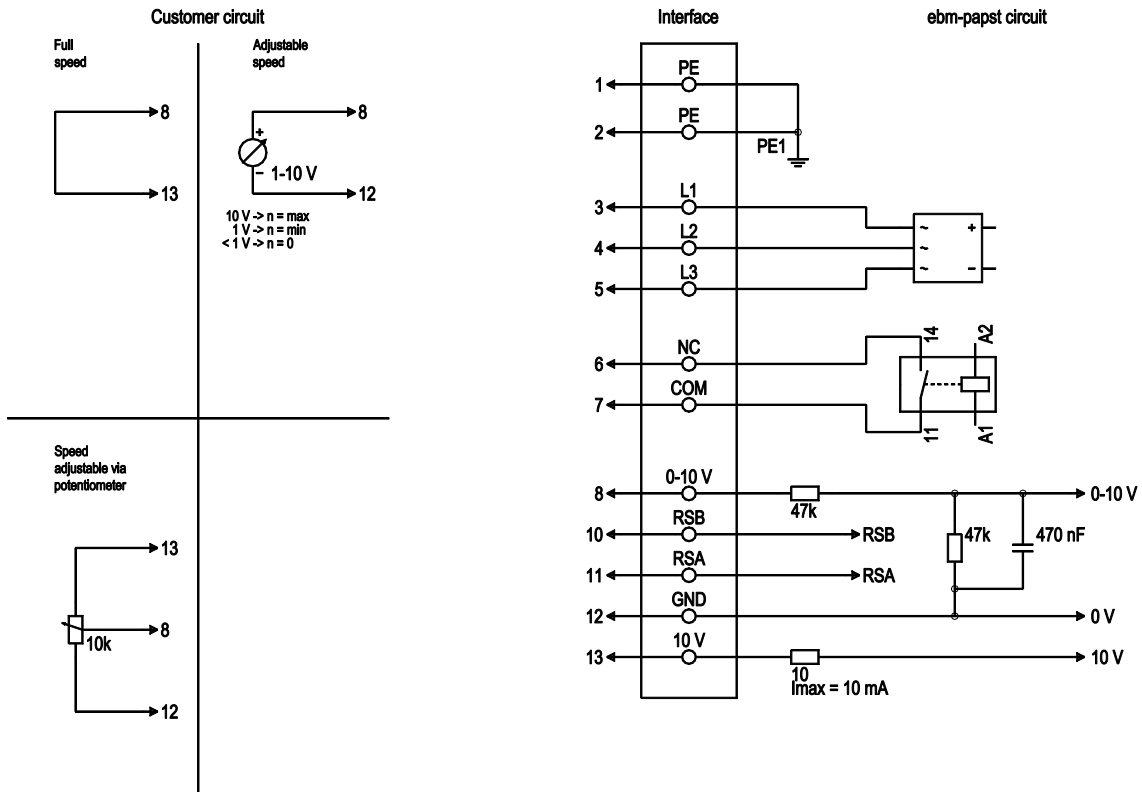

No.	Conn.	Designation	Color	Function/assignment
1	1, 2	PE	green/yellow	Protective earth
1	3	L1	black	Power supply
1	4	L2	black	Power supply
1	5	L3	black	Power supply
1	6	NC	white 1	Status relay, floating status contact, break for failure, contact rating 250 VAC / 2 A (AC1) / min. 10 mA; reinforced insulation on supply side and basic insulation on control interface side
1	7	COM	white 2	Status relay, floating status contact, break for failure, contact rating 250 VAC / 2 A (AC1) / min. 10 mA; reinforced insulation on supply side and basic insulation on control interface side
2	8	0-10V	yellow	Analog input (set value), 0-10 V, $R_i = 100 \text{ k}\Omega$ , adjustable curve, SELV
2	10	RSB	brown	RS485 interface for MODBUS, RSB; SELV
2	11	RSA	white	RS485 interface for MODBUS, RSA; SELV
2	12	GND	blue	Reference ground for control interface, SELV
2	13	+10V	red	Fixed voltage output 10 VDC, $+10 \text{ V} \pm 3\%$ , max. 10 mA, short-circuit-proof power supply for external devices (e.g. pot), SELV fixed voltage input 24 VDC for setting parameters via MODBUS without line voltage supply

## Curves: Air performance 50 Hz

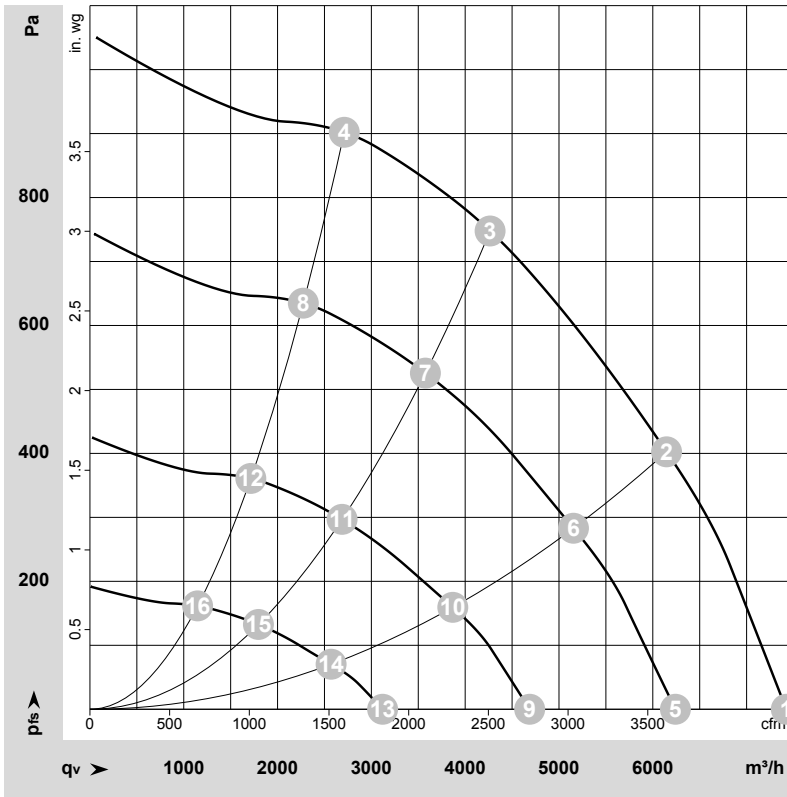

$\rho = 1.15 \text{ kg/m}^3 \pm 2 \%$

Measurement: LU-219895-1  
Date: 2022-03-07  
Nozzle: 8217101929

Air performance measured according to ISO 5801 installation category A. For detailed information on the measurement setup, contact ebmpapst. Intake sound level: Sound power level according to ISO 13347 / sound pressure level measured at 1 m distance from fan axis. The values given are valid under the specified measuring conditions and may vary due to conditions of installation. For deviations from the standard configuration, the parameters have to be checked on the installed unit.

## Measured values

	Wired	U	f	n	P <sub>e</sub>	I	LpA <sub>in</sub>	LwA <sub>in</sub>	LwA <sub>out</sub>	LwA	q <sub>v</sub>	P <sub>fs</sub>	q <sub>v</sub>	P <sub>fs</sub>
		V	Hz	min <sup>-1</sup>	W	A	dB(A)	dB(A)	dB(A)	dB	m <sup>3</sup> /h	Pa	cfm	in. wg
1	3~	400	50	2480	942	1.46	78	86	90	92	7425	0	4370	0.00
2	3~	400	50	2480	1242	1.91	72	79	84	85	6145	400	3620	1.61
3	3~	400	50	2480	1400	2.20	70	76	81	82	4265	750	2510	3.01
4	3~	400	50	2480	1292	1.98	74	80	85	86	2710	900	1595	3.61
5	3~	400	50	2080	571	0.92	74	82	86	87	6240	0	3675	0.00
6	3~	400	50	2080	736	1.16	68	75	79	81	5155	283	3035	1.14
7	3~	400	50	2080	826	1.29	66	72	77	78	3575	528	2105	2.12
8	3~	400	50	2080	760	1.19	69	75	79	81	2275	640	1340	2.57
9	3~	400	50	1565	261	0.49	67	75	79	80	4690	0	2760	0.00
10	3~	400	50	1565	332	0.58	61	68	72	74	3870	159	2275	0.64
11	3~	400	50	1565	367	0.63	59	65	70	71	2690	298	1580	1.20
12	3~	400	50	1565	342	0.60	61	68	72	73	1715	363	1010	1.46
13	3~	400	50	1050	95	0.27	58	66	70	72	3120	0	1835	0.00
14	3~	400	50	1050	115	0.30	52	60	64	65	2570	70	1515	0.28
15	3~	400	50	1050	126	0.32	51	57	61	62	1795	133	1055	0.53
16	3~	400	50	1050	119	0.30	51	57	61	63	1150	163	675	0.65

Wired = Wiring · U = Voltage · f = Frequency · n = Speed (rpm) · P<sub>e</sub> = Power consumption · I = Current draw · LpA<sub>in</sub> = Sound pressure level intake side · LwA<sub>in</sub> = Sound power level intake side  
LwA<sub>out</sub> = Sound power level outlet side · q<sub>v</sub> = Air flow · P<sub>fs</sub> = Pressure increase