

8300100414  
VBH0560STTPS

# EC centrifugal module - RadiCal

backward-curved, single-intake  
with support bracket

8300100414 ebmpapst Datasheet  
sales@fansco.com  
www.fansco.com

Limited partnership · Headquarters Mulfingen  
Amtsgericht (court of registration) Stuttgart · HRA 590344  
General partner Elektrobau Mulfingen GmbH · Headquarters Mulfingen  
Amtsgericht (court of registration) Stuttgart · HRB 590142

## Nominal data

Item	8300100414	
Motor	E15037-85	
Phase		3~
Nominal voltage	VAC	400
Nominal voltage range	VAC	380 .. 480
Frequency	Hz	50/60
Method of obtaining data		ml
Speed (rpm)	min <sup>-1</sup>	1880
Power consumption	W	4000
Current draw	A	5.8
Min. ambient temperature	°C	-40
Max. ambient temperature	°C	40

ml = Max. load · me = Max. efficiency · fa = Free air · cs = Customer specification · ce = Customer equipment  
Subject to change

## Data according to Commission Regulation (EU) 327/2011 (prEN 17166)

		Actual	Req. 2015			
01 Overall efficiency $\eta_{es}$	%	72.4	57.8	09 Power consumption $P_{ed}$	kW	3.97
02 Measurement category		A		09 Air flow $q_v$	m <sup>3</sup> /h	11020
03 Efficiency category		Static		09 Pressure increase $p_{fs}$	Pa	904
04 Efficiency grade N		76.6	62	10 Speed (rpm) n	min <sup>-1</sup>	1875
05 Variable speed drive		Yes		11 Specific ratio <sup>*</sup>		1.01

Data obtained at optimum efficiency level.

<sup>\*</sup> Specific ratio =  $1 + p_s / 100\,000\text{ Pa}$

LU-219585

The efficiency values displayed for achieving conformity with the Ecodesign Regulation EU 327/2011 has been reached with defined air duct components (e.g. inlet rings).  
The dimensions must be requested from ebm-papst. If other air conduction geometries are used on the installation side, the ebm-papst evaluation loses its validity/the conformity must be confirmed again.  
The product does not fall within the scope of Regulation (EU) 2019/1781 due to the exception specified in Article 2 (2a) (motors completely integrated into a product).



8300100414  
VBH0560STTPS

# EC centrifugal module - RadiCal

backward-curved, single-intake  
with support bracket

## Technical description

Size	560 mm
Motor size	150
Rotor surface	Painted black
Electronics housing material	Die-cast aluminum
Impeller material	PP plastic
Support plate material	Sheet steel, galvanized
Support bracket material	Steel, painted black
Inlet nozzle material	Sheet steel, galvanized
Number of blades	6
Direction of rotation	Clockwise, viewed toward rotor
Degree of protection	IP55
Insulation class	"F"
Moisture (F) / Environmental (H) protection class	H1
Ambient temperature note	Occasional start-up at temperatures between -40°C and -25°C is permitted. For continuous operation at ambient temperatures below -25°C (such as refrigeration applications), use must be made of a fan design with special low-temperature bearings.
Max. permitted ambient temp. for motor (transport/storage)	+80 °C
Min. permitted ambient temp. for motor (transport/storage)	-40 °C
Installation position	See legend on product drawing
Condensation drainage holes	On rotor side
Mode	S1
Motor bearing	Ball bearing; (sealed)
Technical features	<ul style="list-style-type: none"><li>- Operation and alarm display with LED</li><li>- External 15-50 VDC input (parameterization)</li><li>- Alarm relay</li><li>- Integrated PI controller</li><li>- Configurable inputs/outputs (I/O)</li><li>- MODBUS V6.4</li><li>- Motor current limitation</li><li>- PFC, active</li><li>- RS-485 MODBUS-RTU</li><li>- Soft start</li><li>- Voltage output 3.3-24 VDC, Pmax = 800 mW</li><li>- Control interface with SELV potential safely disconnected from the mains</li><li>- Thermal overload protection for electronics/motor</li><li>- Line undervoltage / phase failure detection</li><li>- Vibration sensor</li></ul>
Touch current according to IEC 60990 (measuring circuit Fig. 4, TN system)	<= 3.5 mA
Electrical hookup	Terminal box
Motor protection	Electronic motor protection



8300100414  
VBH0560STTPS

# EC centrifugal module - RadiCal

backward-curved, single-intake  
with support bracket

<b>Protection class assignment</b>	I; If a protective earth is connected by the customer This component for installation may have several local protection classes. This information relates to this component's basic design. The final protection class is based on the component's intended installation and connection.
<b>Conformity with standards</b>	EN 61800-5-1; CE; UKCA
<b>Approval</b>	CSA C22.2 No. 77 + CAN/CSA-E60730-1; EAC; UL 1004-7 + 60730-1



8300100414  
VBH0560STTPS

# EC centrifugal module - RadiCal

backward-curved, single-intake  
with support bracket

## Product drawing

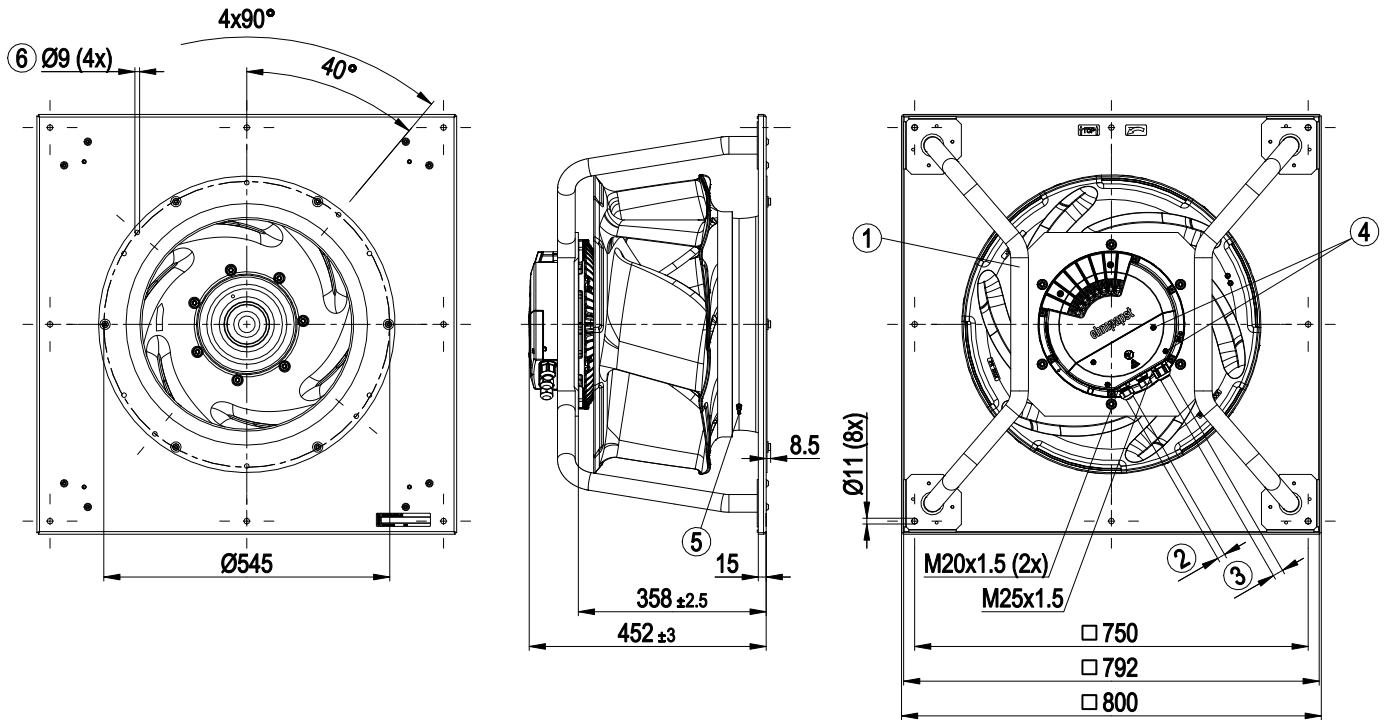

1	Installed position: shaft horizontal (install support struts only vertically as illustrated) or rotor on bottom; rotor on top on request
2	Cable diameter min. 4 mm, max. 10 mm, tightening torque $4 \pm 0.6$ Nm
3	Cable diameter min. 5 mm, max. 14 mm, tightening torque $6 \pm 0.9$ Nm (The tightening torque is designed for PVC cables. If the cable materials are different, the tightening torque may have to be adjusted)
4	Tightening torque $3 \pm 0.3$ Nm
5	Inlet ring with pressure tap (k-factor: 425)
6	Attachment holes for FlowGrid 00630-2-2957 (not included in scope of delivery)



# EC centrifugal module - RadiCal

backward-curved, single-intake  
with support bracket

## Connection diagram

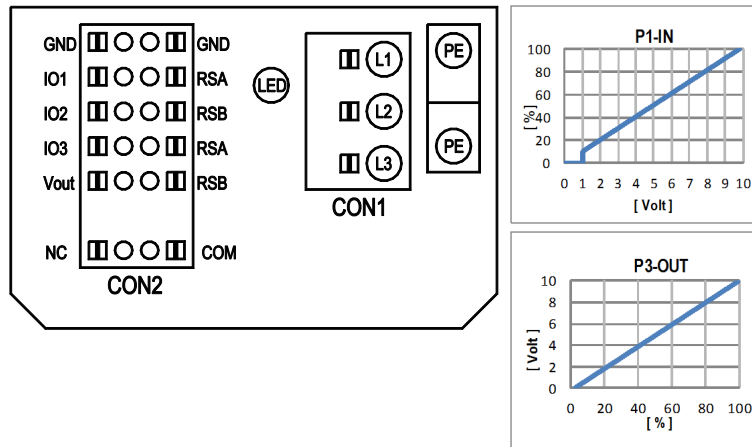

No.	Conn.	Designation	Function/assignment
	CON1	L1, L2, L3	Power supply, phase, see nameplate for voltage range
	PE	PE	Protective earth
	CON2	RSA	RS485 interface for MODBUS, RSA; SELV
	CON2	RSB	RS485 interface for MODBUS, RSB; SELV
	CON2	GND	Reference ground for control interface, SELV
	CON2	IO1	Function parameterizable (see "Optional interface functions" table) Factory setting: Digital input - high active, function: Disable input, SELV - inactive: Pin open or applied voltage < 1.5 VDC - active: applied voltage 3.5-50 VDC Reset function: Triggering of error reset on change of state from "enabled" to "disabled"
	CON2	IO2	Function parameterizable (see "Optional interface functions" table) Factory setting: Analog input 0-10 V/PWM, Ri=100 kΩ, function: set value Characteristic curve parameterizable (see input characteristic curve P1-IN), SELV
	CON2	IO3	Function parameterizable (see "Optional interface functions" table) Factory setting: Analog output 0-10 V, max. 5 mA, function: Actual speed Characteristic curve parametrizable (see output characteristic curve P3-OUT), SELV
	CON2	Vout	Voltage output 3.3-24 VDC +/-5%, Pmax=800 mW, voltage parameterizable Factory setting: 10 VDC short-circuit-proof, supply for external devices, SELV alternatively: 15-50 VDC input for parameterization via MODBUS without line voltage
	CON2	COM	Status relay, floating status contact, common connection, contact rating 250 VAC / 2 A (AC1) / min. 10 mA, reinforced insulation on supply side and on control interface side
	CON2	NC	Status relay, floating status contact, break for failure
		LED	green: status = good, ready for operation orange: status = warning red: status = failure
		P1-IN	Input characteristic curve
		P3-OUT	Output characteristic curve

## Terminal/plug assignment

CON2	configurable IO mode	electrical specification	configurable IO functions: normal / inverse	MODBUS Register for IO mode configuration	
				MODBUS Register for IO mode	configuration
IO1	○ Din1 (active high), digital input	active: applied voltage 3.5-50VDC, SELV not active: pin open or applied voltage < 1.5VDC		D158 [0]	
	○ Ain1 0-10V/PWM: analog input	RI = 100k, characteristic curve parameterizable, $f_{PWM} = 1k..10kHz$ , SELV		D158 [2]	
	○ Tach out (open collector output)	Umax = 50VDC, Imax = 20mA, SELV		D158 [5]	
	○ Diagnostics out (open collector output)	Umax = 50VDC, Imax = 20mA, SELV		D158 [6]	
IO2	○ Din2 (active high), digital input	active: applied voltage 3.5-50VDC, SELV not active: pin open or applied voltage < 1.5VDC		D159 [0]	
	○ Ain2 0-10V/PWM: analog input	RI = 100k, characteristic curve parameterizable, $f_{PWM} = 1k..10kHz$ , SELV		D159 [2]	
	○ Ain2-4-20mA: analog input	RI = 125R, characteristic curve parameterizable, SELV		D159 [3]	
	○ Din3 (active high), digital input	active: applied voltage 3.5-50VDC, SELV not active: pin open or applied voltage < 1.5VDC		D15A [0]	
IO3	○ Din3 (active low), digital input	active: applied voltage < 1.5VDC, SELV not active: pin open or applied voltage 3.5-50VDC		D15A [1]	
	○ PWMIn3: digital input idle level high	PWM = 40Hz - 10kHz, characteristics parameterizable		D15A [7]	
	○ PWMIn3: digital input idle level low	active: pin open or applied voltage 3.5-50VDC not active: applied voltage < 1.5VDC, SELV		D15A [8]	
	○ Aout3 0-10V: analog output	function parameterizable, max. 5mA max output frequency 300Hz SELV		D15A [4]	
RSA	○ Tacho out (pulses), analog output	0-10V/max. 5mA max output frequency 300Hz SELV		D15A [5]	
	○ Diagnostics out (pulses)	0-10V/max. 5mA max output frequency 300Hz, SELV		D15A [6]	
	○ RSA485 bus connection,	MODBUS RTU, specification V6.4, SELV			
RSB					
Vout	voltage output	voltage parameterizable 3.3...24VDC +/- 5%, Pmax=800mW, short-circuit-proof, supply for external devices, SELV		D16E [..]	
	alternatively: Input auxiliary power supply for parameterization via RS485/MODBUS RTU without line voltage	15...50VDC			

IO	Signal	Direction	Notes
D101 [..]	source: set value	○	
D147 [..]	source: sensor value	○	
D104 [..]	switch: parameter set: #1 / #2	○	
D12E [..]	switch: control function: heating (pos.) / cooling (neg.)	○	
D148 [..]	switch: direction of rotation: cw / ccw	○	
D16C [..]	switch: set value source	○	
D16A [..]	switch: fan enable / disable	○	
(selected directly via IO mode)	signal: tach out	○	
(selected directly via IO mode)	signal: diagnostics out	○	
D130 [0]	signal: fan modulation level %		
D130 [1]	signal: actual speed		
D130 [2]	signal: system modulation level %		
D130 [5]	signal: remote control output 0-10V		
D00C [1]	pulse input for auto-addressing	○	
D130 [4]	pulse output for auto-addressing		

○ configurable option

For further information and additional functions see EC Control Software, Fan-Set-App, or MODBUS Parameter Specification V6.4



# EC centrifugal module - RadiCal

backward-curved, single-intake  
with support bracket

## Curves: Air performance 50 Hz

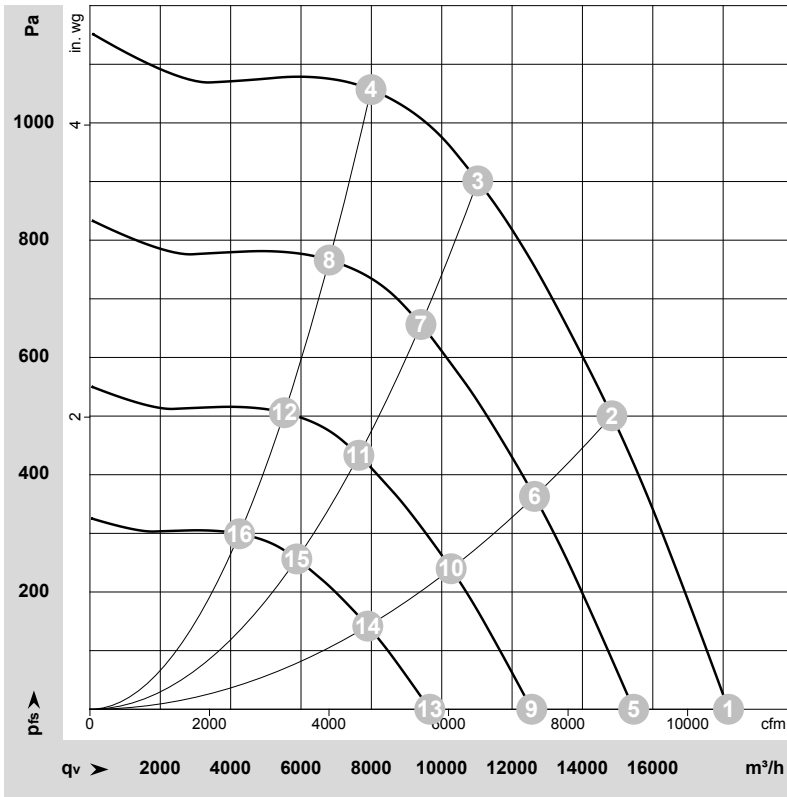

$\rho = 1.15 \text{ kg/m}^3 \pm 2 \%$

Measurement: LU-219585-1

Air performance measured according to ISO 5801 installation category A. For detailed information on the measurement setup, contact ebmpapst. Intake sound level: Sound power level according to ISO 13347 / sound pressure level measured at 1 m distance from fan axis. The values given are valid under the specified measuring conditions and may vary due to conditions of installation. For deviations from the standard configuration, the parameters have to be checked on the installed unit.

## Measured values

	Wired	U	f	n	P <sub>e</sub>	I	LpA <sub>in</sub>	LwA <sub>in</sub>	LwA <sub>out</sub>	LwA	q <sub>v</sub>	P <sub>fs</sub>	q <sub>v</sub>	P <sub>fs</sub>
		V	Hz	min <sup>-1</sup>	W	A	dB(A)	dB(A)	dB(A)	dB	m <sup>3</sup> /h	Pa	cfm	in. wg
1	3~	400	50	1880	2428	3.51	81	89	94	95	18150	0	10685	0.00
2	3~	400	50	1880	3614	5.22	76	83	90	91	14835	500	8735	2.01
3	3~	400	50	1880	4000	5.80	72	80	86	87	11025	900	6490	3.61
4	3~	400	50	1880	3817	5.51	77	84	89	90	7990	1050	4705	4.22
5	3~	400	50	1600	1499	2.17	77	85	90	91	15455	0	9100	0.00
6	3~	400	50	1600	2233	3.22	72	79	86	87	12635	365	7440	1.47
7	3~	400	50	1600	2476	3.57	68	76	82	83	9410	658	5540	2.64
8	3~	400	50	1600	2354	3.40	73	80	85	86	6805	769	4005	3.09
9	3~	400	50	1300	804	1.16	72	80	84	86	12560	0	7390	0.00
10	3~	400	50	1300	1198	1.73	66	74	81	81	10270	241	6045	0.97
11	3~	400	50	1300	1328	1.92	62	70	76	77	7645	435	4500	1.75
12	3~	400	50	1300	1263	1.82	68	75	80	81	5530	508	3255	2.04
13	3~	400	50	1000	366	0.53	65	73	78	79	9660	0	5685	0.00
14	3~	400	50	1000	545	0.79	60	67	74	75	7900	143	4650	0.57
15	3~	400	50	1000	605	0.87	56	64	70	71	5880	257	3460	1.03
16	3~	400	50	1000	575	0.83	61	69	73	74	4250	300	2505	1.20

Wired = Wiring · U = Voltage · f = Frequency · n = Speed (rpm) · P<sub>e</sub> = Power consumption · I = Current draw · LpA<sub>in</sub> = Sound pressure level intake side · LwA<sub>in</sub> = Sound power level intake side  
LwA<sub>out</sub> = Sound power level outlet side · q<sub>v</sub> = Air flow · P<sub>fs</sub> = Pressure increase

