

8300100405
VBS0450CTPMS

EC centrifugal fan - RadiPac

backward-curved, single-intake

8300100405 ebmpapst Datasheet

sales@fansco.com

www.fansco.com

Nominal data

Item	8300100405	
Motor	E08423-65	
Phase		3~
Nominal voltage	VAC	400
Nominal voltage range	VAC	380 .. 480
Frequency	Hz	50/60
Method of obtaining data		ml
Status		prelim.
Speed (rpm)	min ⁻¹	1860
Power consumption	W	1070
Current draw	A	1.7
Min. ambient temperature	°C	-40
Max. ambient temperature	°C	40

ml = Max. load · me = Max. efficiency · fa = Free air · cs = Customer specification · ce = Customer equipment
Subject to change

Data according to Commission Regulation (EU) 327/2011 (EN 17166)

		Actual	Req. 2015			
01 Overall efficiency η_{es}	%	68.3	51.8	09 Power consumption P_{ed}	kW	1.06
02 Measurement category		A		09 Air flow q_v	m ³ /h	5025
03 Efficiency category		Static		09 Pressure increase p_{fs}	Pa	483
04 Efficiency grade N		78.5	62	10 Speed (rpm) n	min ⁻¹	1865
05 Variable speed drive		Yes		11 Specific ratio [*]		1.01

Data obtained at optimum efficiency level.

^{*} Specific ratio = $1 + p_{fs} / 100\,000\text{ Pa}$

LU-220790

The efficiency values displayed for achieving conformity with the Ecodesign Regulation EU 327/2011 has been reached with defined air duct components (e.g. inlet rings).
The dimensions must be requested from ebm-papst. If other air conduction geometries are used on the installation side, the ebm-papst evaluation loses its validity/the conformity must be confirmed again.
The product does not fall within the scope of Regulation (EU) 2019/1781 due to the exception specified in Article 2 (2a) (motors completely integrated into a product).



8300100405
VBS0450CTPMS

EC centrifugal fan - RadiPac

backward-curved, single-intake

Technical description

Size	450 mm
Motor size	84
Rotor surface	Painted black
Electronics housing material	Die-cast aluminum
Impeller material	PP plastic
Number of blades	5
Direction of rotation	Clockwise, viewed toward rotor
Degree of protection	IP55
Insulation class	"F"
Moisture (F) / Environmental (H) protection class	H1
Ambient temperature note	Occasional start-up at temperatures between -40°C and -25°C is permitted. For continuous operation at ambient temperatures below -25°C (such as refrigeration applications), use must be made of a fan design with special low-temperature bearings.
Max. permitted ambient temp. for motor (transport/storage)	+80 °C
Min. permitted ambient temp. for motor (transport/storage)	-40 °C
Installation position	Shaft horizontal or rotor on bottom; rotor on top on request
Condensation drainage holes	On rotor side
Mode	S1
Motor bearing	Ball bearing
Technical features	<ul style="list-style-type: none">- Output 10 VDC, max. 10 mA- Operation and alarm display- External 24 V input (parameter setting)- Alarm relay- Integrated PID controller- MODBUS V5.1- Motor current limitation- PFC, passive- RS-485 MODBUS-RTU- Soft start- EEPROM write cycles: 100,000 maximum- Control input 0-10 VDC / PWM- Control interface with SELV potential safely disconnected from the mains- Thermal overload protection for electronics/motor- Line undervoltage / phase failure detection
Touch current according to IEC 60990 (measuring circuit Fig. 4, TN system)	<= 3.5 mA
Motor protection	Thermal overload protector (TOP) internally connected
With cable	Lateral
Protection class assignment	I; If a protective earth is connected by the customer This component for installation may have several local protection classes. This information relates to this component's basic design. The final protection class is based on the component's intended installation and connection.
Conformity with standards	EN 61800-5-1; CE; UKCA
Approval	CSA C22.2 No. 77 + CAN/CSA-E60730-1; EAC; UL 1004-7 + 60730-1



8300100405
VBS0450CTPMS

EC centrifugal fan - RadiPac

backward-curved, single-intake

Product drawing

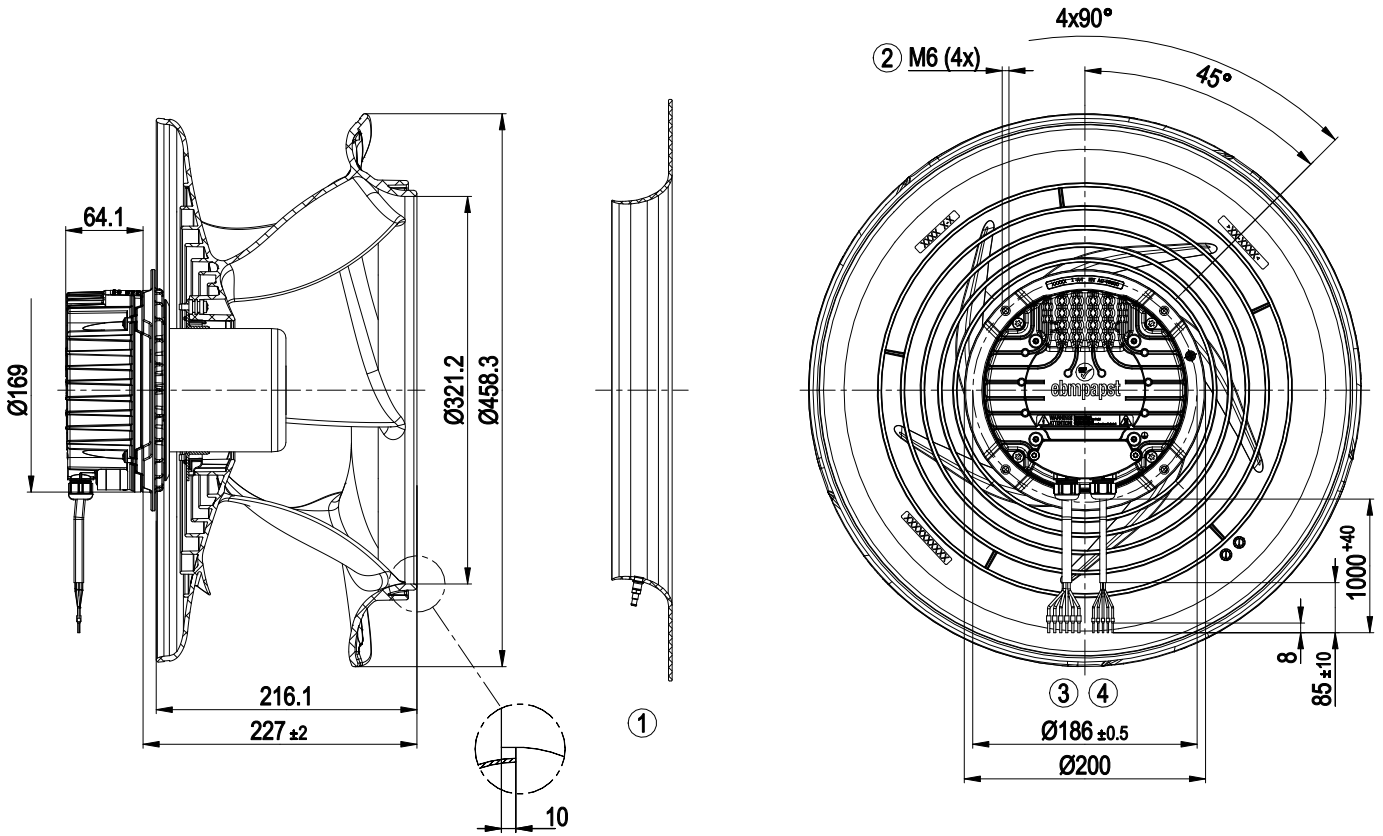

1	Accessory part: Inlet ring 8217102239 with pressure tap (k-factor: 232) (not included in scope of delivery)
2	Max. clearance for screw 16 mm
3	Cable PVC AWG18 6x wire-end ferrule
4	Cable PVC AWG22 5x wire-end ferrule



8300100405
VBS0450CTPMS

EC centrifugal fan - RadiPac

backward-curved, single-intake

Accessory part

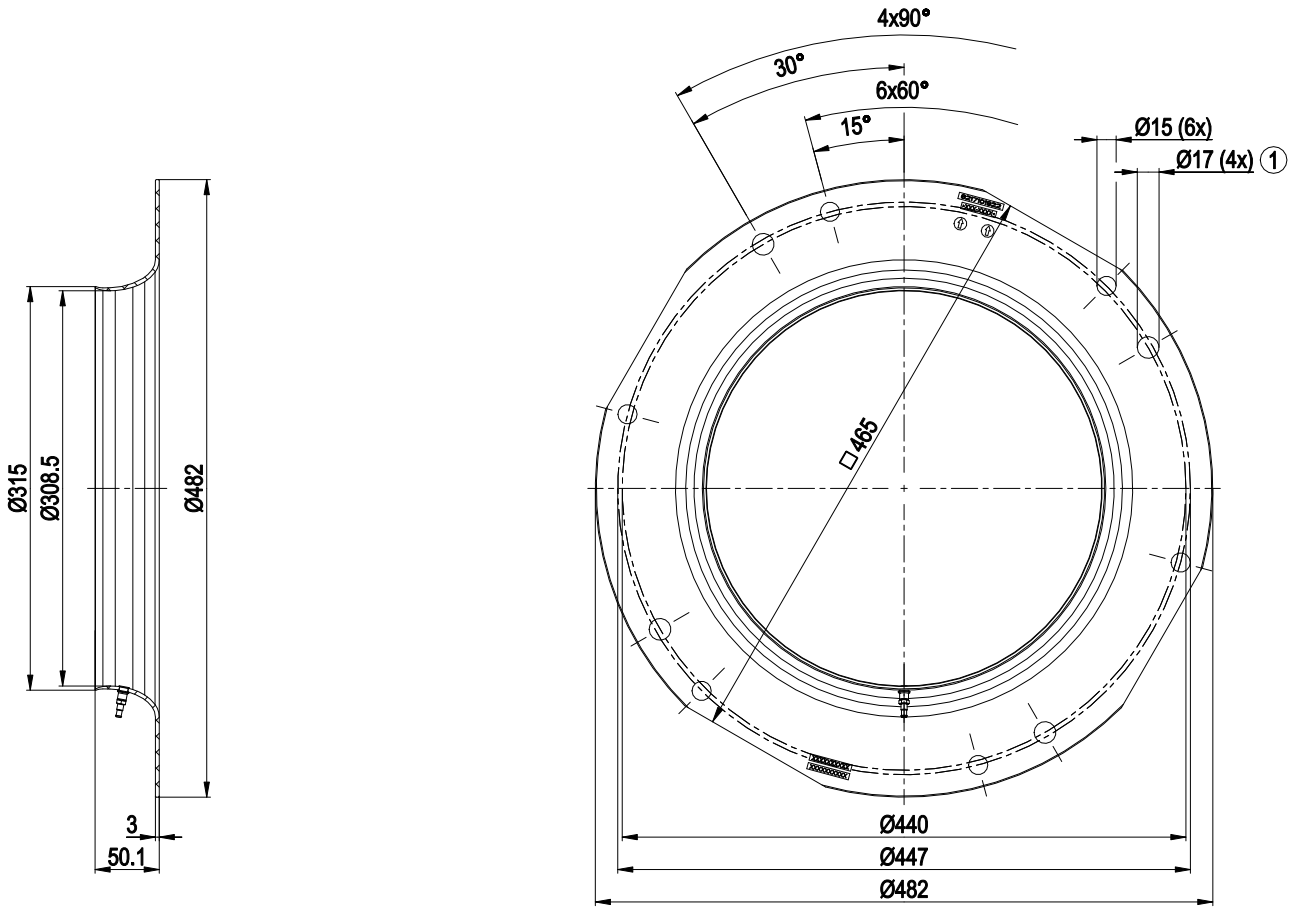

Inlet ring 8217102239 with pressure tap (k-factor: 232)

- 1 Fastening holes for FlowGrid 35505-2-2957 (not included in scope of delivery) are provided and must be subsequently opened as required



Connection diagram

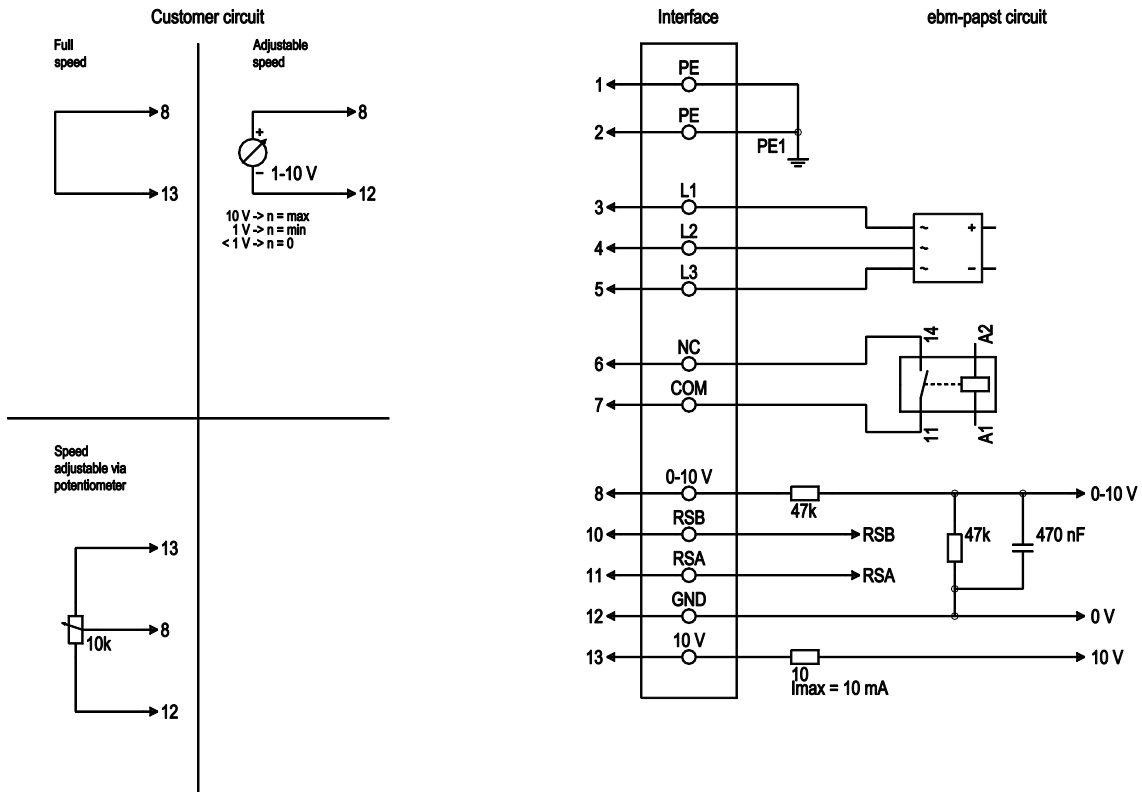

No.	Conn.	Designation	Color	Function/assignment
1	1, 2	PE	green/yellow	Protective earth
1	3	L1	black	Power supply
1	4	L2	black	Power supply
1	5	L3	black	Power supply
1	6	NC	white 1	Status relay, floating status contact, break for failure, contact rating 250 VAC / 2 A (AC1) / min. 10 mA; reinforced insulation on supply side and basic insulation on control interface side
1	7	COM	white 2	Status relay, floating status contact, break for failure, contact rating 250 VAC / 2 A (AC1) / min. 10 mA; reinforced insulation on supply side and basic insulation on control interface side
2	8	0-10V	yellow	Analog input (set value), 0-10 V, $R_i = 100\text{ k}\Omega$, adjustable curve, SELV
2	10	RSB	brown	RS485 interface for MODBUS, RSB; SELV
2	11	RSA	white	RS485 interface for MODBUS, RSA; SELV
2	12	GND	blue	Reference ground for control interface, SELV
2	13	+10V	red	Fixed voltage output 10 VDC, $+10\text{ V} \pm 3\%$, max. 10 mA, short-circuit-proof power supply for external devices (e.g. pot), SELV fixed voltage input 24 VDC for setting parameters via MODBUS without line voltage supply

Curves: Air performance 50 Hz

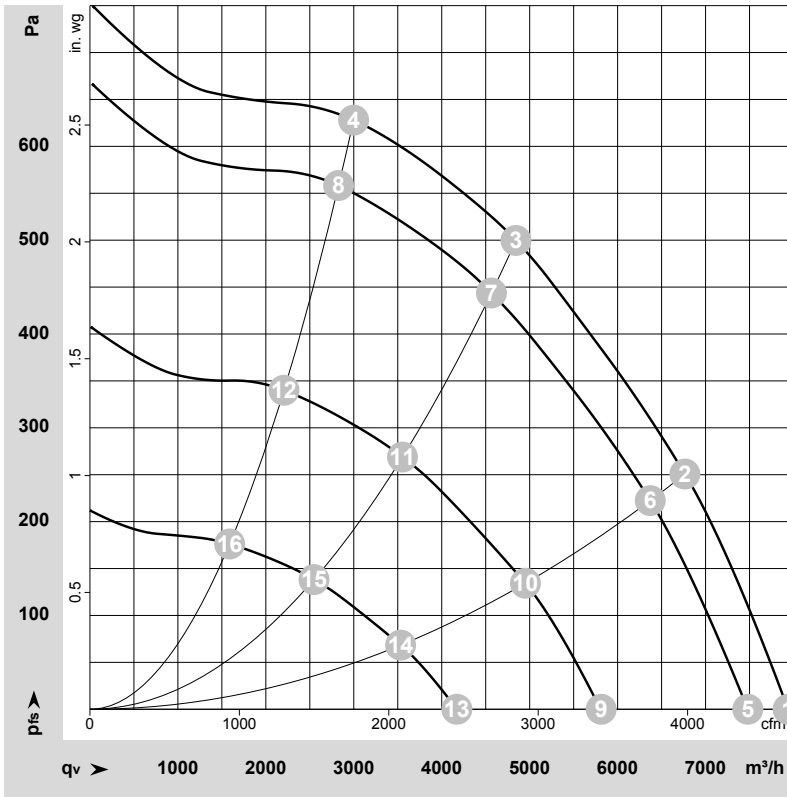

$\rho = 1.15 \text{ kg/m}^3 \pm 2 \%$

Measurement: LU-220790-1

Air performance measured according to ISO 5801 installation category A. For detailed information on the measurement setup, contact ebmpapst. Intake sound level: Sound power level according to ISO 13347 / sound pressure level measured at 1 m distance from fan axis. The values given are valid under the specified measuring conditions and may vary due to conditions of installation. For deviations from the standard configuration, the parameters have to be checked on the installed unit.

Measured values

	Wired	U	f	n	P _e	I	LpA _{in}	LwA _{in}	LwA _{out}	LwA	q _v	P _{fs}	q _v	P _{fs}
		V	Hz	min ⁻¹	W	A	dB(A)	dB(A)	dB(A)	dB	m ³ /h	Pa	cfm	in. wg
1	3~	400	50	1860	705	1.11	76	84	88	89	7940	0	4675	0.00
2	3~	400	50	1860	919	1.43	71	78	83	84	6765	250	3980	1.00
3	3~	400	50	1860	1070	1.70	67	73	78	79	4845	500	2850	2.01
4	3~	400	50	1860	991	1.53	69	75	79	81	3000	630	1765	2.53
5	3~	400	50	1755	594	0.95	75	82	87	88	7480	0	4405	0.00
6	3~	400	50	1755	775	1.21	69	77	82	83	6370	222	3750	0.89
7	3~	400	50	1755	895	1.39	65	72	77	78	4565	444	2685	1.78
8	3~	400	50	1755	829	1.29	67	73	78	79	2825	559	1665	2.24
9	3~	400	50	1370	292	0.53	68	76	80	81	5815	0	3420	0.00
10	3~	400	50	1370	372	0.64	63	71	75	77	4950	134	2915	0.54
11	3~	400	50	1370	422	0.71	59	66	70	72	3555	269	2090	1.08
12	3~	400	50	1370	394	0.67	60	67	71	72	2205	340	1300	1.36
13	3~	400	50	990	126	0.31	61	69	73	75	4170	0	2455	0.00
14	3~	400	50	985	153	0.35	56	64	68	70	3535	68	2080	0.27
15	3~	400	50	985	172	0.38	52	58	63	64	2550	138	1500	0.55
16	3~	400	50	985	162	0.37	52	58	62	64	1590	176	935	0.71

Wired = Wiring · U = Voltage · f = Frequency · n = Speed (rpm) · P_e = Power consumption · I = Current draw · LpA_{in} = Sound pressure level intake side · LwA_{in} = Sound power level intake side
LwA_{out} = Sound power level outlet side · q_v = Air flow · P_{fs} = Pressure increase

