

8300100398

VMA0630HSPMZ

# EC axial fan - HyBlade

sickle-shaped blades (S series)

with guard grille for full nozzle

8300100398 ebmpapst Datasheet

sales@fansco.com

www.fansco.com

## Nominal data

<b>Item</b>	<b>8300100398</b>	
<b>Motor</b>	<b>E08421-65</b>	
Phase		1~
Nominal voltage	VAC	230
Nominal voltage range	VAC	200 .. 277
Frequency	Hz	50/60
Method of obtaining data		ml
Status		prelim.
Speed (rpm)	min <sup>-1</sup>	800
Power consumption	W	265
Current draw	A	1.2
Max. back pressure	Pa	75
Max. back pressure	in. wg	0.3
Min. ambient temperature	°C	-25
Max. ambient temperature	°C	60

ml = Max. load · me = Max. efficiency · fa = Free air · cs = Customer specification · ce = Customer equipment  
Subject to change

## Data according to Commission Regulation (EU) 327/2011 (prEN 17166)

		Actual	Req. 2015			
01 Overall efficiency $\eta_{es}$	%	47	29.9	09 Power consumption $P_{ed}$	kW	0.24
02 Measurement category		A		09 Air flow $q_v$	m <sup>3</sup> /h	6010
03 Efficiency category		Static		09 Pressure increase $p_{fs}$	Pa	65
04 Efficiency grade N		57.1	40	10 Speed (rpm) n	min <sup>-1</sup>	805
05 Variable speed drive		Yes		11 Specific ratio*		1.00

Data obtained at optimum efficiency level.

\* Specific ratio =  $1 + p_g / 100\,000\text{ Pa}$

LU-189802

The efficiency values displayed for achieving conformity with the Ecodesign Regulation EU 327/2011 has been reached with defined air duct components (e.g. inlet rings).  
The dimensions must be requested from ebm-papst. If other air conduction geometries are used on the installation side, the ebm-papst evaluation loses its validity/the conformity must be confirmed again.  
The product does not fall within the scope of Regulation (EU) 2019/1781 due to the exception specified in Article 2 (2a) (motors completely integrated into a product).



8300100398

VMA0630HSPMZ

# EC axial fan - HyBlade

sickle-shaped blades (S series)

with guard grille for full nozzle

## Technical description

<b>Weight</b>	9.7 kg
<b>Size</b>	630 mm
<b>Motor size</b>	84
<b>Rotor surface</b>	Painted black
<b>Electronics housing material</b>	Die-cast aluminum, painted black
<b>Blade material</b>	Press-fitted sheet steel blank, sprayed with PP plastic
<b>Guard grille material</b>	Steel, coated with black plastic (RAL 9005)
<b>Airflow direction</b>	V
<b>Direction of rotation</b>	Counterclockwise, viewed toward rotor
<b>Degree of protection</b>	IP55
<b>Insulation class</b>	"F"
<b>Moisture (F) / Environmental (H) protection class</b>	H2+
<b>Max. permitted ambient temp. for motor (transport/storage)</b>	+80 °C
<b>Min. permitted ambient temp. for motor (transport/storage)</b>	-40 °C
<b>Installation position</b>	Shaft horizontal or rotor on bottom; rotor on top on request
<b>Condensation drainage holes</b>	On rotor side
<b>Mode</b>	S1
<b>Motor bearing</b>	Ball bearing made of stainless steel; (sealed)
<b>Technical features</b>	<ul style="list-style-type: none"> <li>- Output 10 VDC, max. 10 mA</li> <li>- Operation and alarm display</li> <li>- Alarm relay</li> <li>- Integrated PID controller</li> <li>- Power limiter</li> <li>- Motor current limitation</li> <li>- PFC, active</li> <li>- RS-485 MODBUS-RTU</li> <li>- Soft start</li> <li>- Control input 0-10 VDC / PWM</li> <li>- Control interface with SELV potential safely disconnected from the mains</li> <li>- Thermal overload protection for electronics/motor</li> <li>- Line undervoltage / phase failure detection</li> </ul>
<b>EMC immunity to interference</b>	According to EN 61000-6-2 (industrial environment)
<b>EMC circuit feedback</b>	According to EN 61000-3-2/3
<b>EMC interference emission</b>	According to EN 61000-6-3 (household environment)
<b>Touch current according to IEC 60990 (measuring circuit Fig. 4, TN system)</b>	<= 3.5 mA
<b>Electrical hookup</b>	Connector with cable
<b>Motor protection</b>	Thermal overload protector (TOP) internally connected
<b>With cable</b>	Variable
<b>Protection class assignment</b>	I; If a protective earth is connected by the customer This component for installation may have several local protection classes. This information relates to this component's basic design. The final protection class is based on the component's intended installation and connection.
<b>Conformity with standards</b>	EN 61800-5-1; CE



8300100398  
VMA0630HSPMZ

## EC axial fan - HyBlade

sickle-shaped blades (S series)  
with guard grille for full nozzle

Approval

UL 1004-7 + 60730-1; EAC; CSA C22.2 No. 77 + CAN/CSA-E60730-1



8300100398  
VMA0630HSPMZ

# EC axial fan - HyBlade

sickle-shaped blades (S series)  
with guard grille for full nozzle

## Product drawing

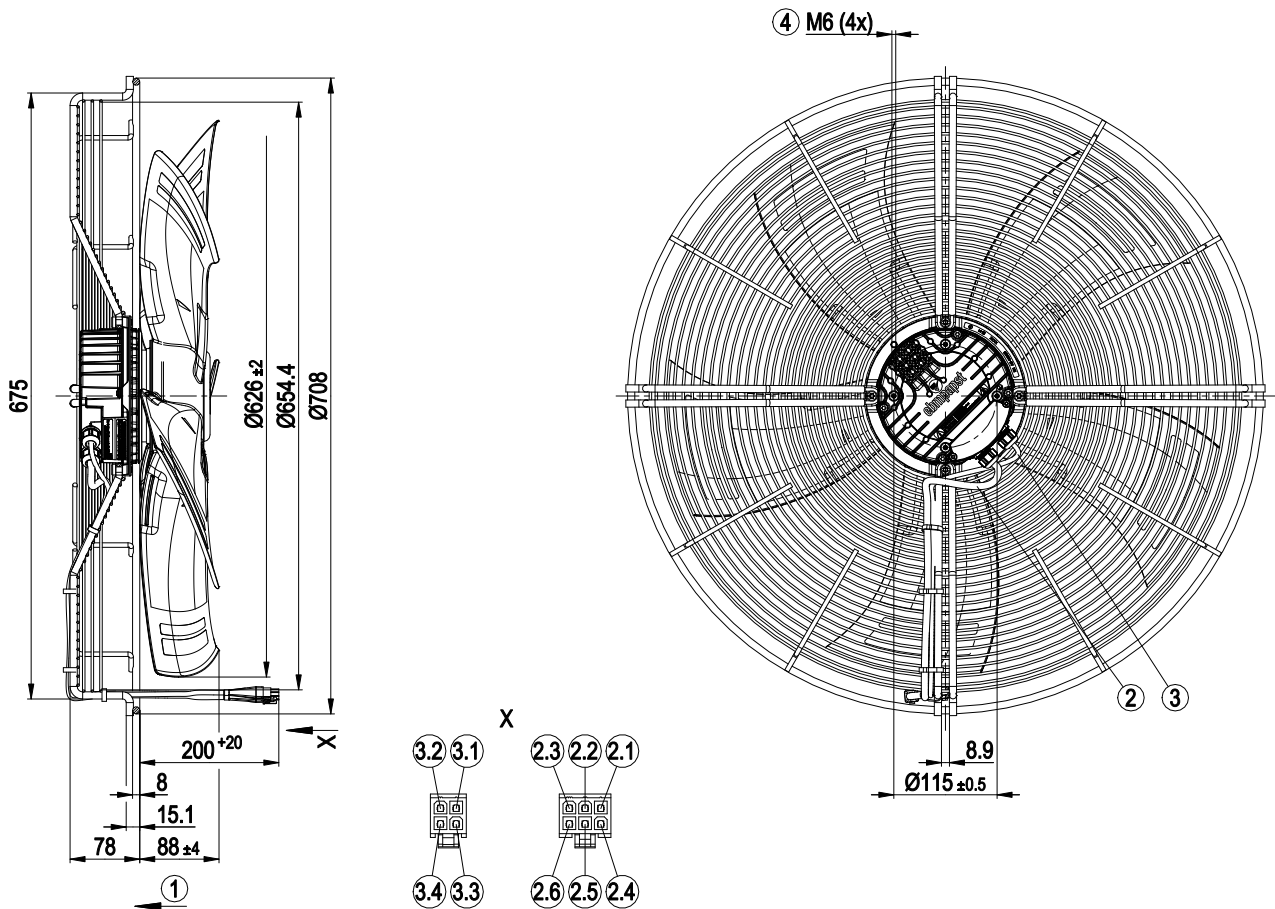

1	Airflow direction "V"
2	Cable PVC AWG18 6-pole connector housing Molex 46992-0610, 5x socket Molex 39-00-0059
2.1	N
2.2	PE
2.3	L
2.4	not used
2.5	COM
2.6	NC
3	Cable PVC AWG22 4-pole connector housing Molex 46992-0410, 3x socket Molex 39-00-0059
3.1	GND
3.2	0-10 V/PWM
3.3	+10 V
3.4	not used
4	Max. clearance for screw 12 mm



# EC axial fan - HyBlade

sickle-shaped blades (S series)  
with guard grille for full nozzle

## Connection diagram

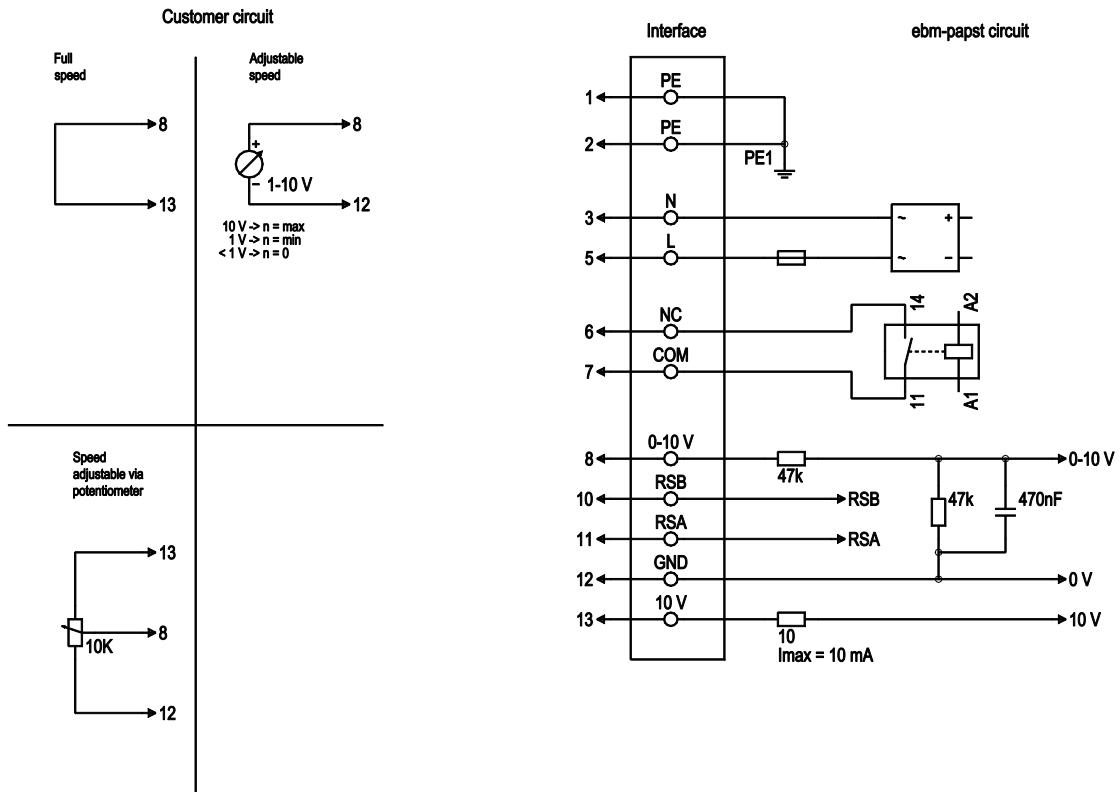

No.	Conn.	Designation	Color	Function/assignment
1	1, 2	PE	green/yellow	Protective earth
1	3	N	blue	Power supply, neutral conductor, 50/60 Hz
1	5	L	black	Power supply, phase, 50/60 Hz
1	6	NC	white 1	Status relay, floating status contact; break for failure, contact rating 250 VAC/2 A (AC1) min. 10 mA, basic insulation on supply side and reinforced insulation on control interface side
1	7	COM	white 2	Status relay, floating status contact; common connection, contact rating 250 VAC/2 A (AC1) min. 10 mA, basic insulation on supply side and reinforced insulation on control interface side
2	8	0-10V	yellow	Analog input (set value); 0-10 V; $R_i = 100\text{ k}\Omega$ ; adjustable curve
2	10	RSB		not brought out via wire
2	11	RSA		not brought out via wire
2	12	GND	blue	Reference ground for control interface, SELV
2	13	+10V	red	Fixed voltage output 10 VDC; +10 V +/-3%; max. 10 mA; short-circuit-proof; power supply for ext. devices (e.g. potentiometer)



# EC axial fan - HyBlade

sickle-shaped blades (S series)  
with guard grille for full nozzle

## Curves: Air performance 50 Hz

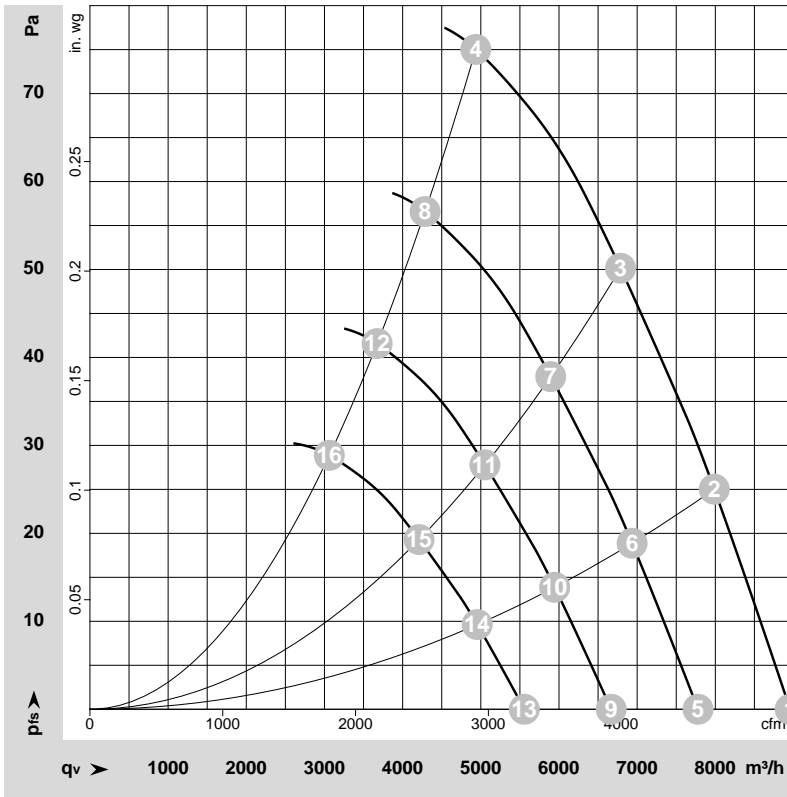

$\rho = 1.15 \text{ kg/m}^3 \pm 2 \%$

Measurement: LU-189802-1

Air performance measured according to ISO 5801 installation category A. For detailed information on the measurement setup, contact ebmpapst. Intake sound level: Sound power level according to ISO 13347 / sound pressure level measured at 1 m distance from fan axis. The values given are valid under the specified measuring conditions and may vary due to conditions of installation. For deviations from the standard configuration, the parameters have to be checked on the installed unit.

## Measured values

	Wired	U	f	n	P <sub>e</sub>	I	LpA <sub>in</sub>	LwA <sub>in</sub>	LwA <sub>out</sub>	LwA	q <sub>v</sub>	P <sub>fs</sub>	q <sub>v</sub>	P <sub>fs</sub>
		V	Hz	min <sup>-1</sup>	W	A	dB(A)	dB(A)	dB(A)	dB	m <sup>3</sup> /h	Pa	cfm	in. wg
1	1~	230	50	800	172	0.77	56	62	62	65	8955	0	5270	0.00
2	1~	230	50	800	208	0.94	57	63	62	65	7985	25	4700	0.10
3	1~	230	50	800	237	1.06	57	63	62	66	6785	50	3995	0.20
4	1~	230	50	800	265	1.20	61	68	68	71	4935	75	2905	0.30
5	1~	230	50	700	113	0.51	53	59	58	62	7780	0	4580	0.00
6	1~	230	50	700	136	0.61	53	59	58	62	6935	19	4080	0.08
7	1~	230	50	700	155	0.70	54	60	59	62	5895	38	3470	0.15
8	1~	230	50	700	173	0.77	58	65	65	68	4285	57	2525	0.23
9	1~	230	50	600	71	0.32	49	55	55	58	6670	0	3925	0.00
10	1~	230	50	600	86	0.39	50	55	54	58	5945	14	3500	0.06
11	1~	230	50	600	98	0.44	50	56	55	58	5050	28	2975	0.11
12	1~	230	50	600	109	0.48	54	61	61	64	3675	42	2160	0.17
13	1~	230	50	500	41	0.18	44	50	50	53	5555	0	3270	0.00
14	1~	230	50	500	50	0.22	45	51	50	53	4955	10	2915	0.04
15	1~	230	50	500	57	0.25	45	51	50	54	4210	19	2480	0.08
16	1~	230	50	500	63	0.28	49	56	56	59	3060	29	1800	0.12

Wired = Wiring · U = Voltage · f = Frequency · n = Speed (rpm) · P<sub>e</sub> = Power consumption · I = Current draw · LpA<sub>in</sub> = Sound pressure level intake side · LwA<sub>in</sub> = Sound power level intake side  
LwA<sub>out</sub> = Sound power level outlet side · q<sub>v</sub> = Air flow · P<sub>fs</sub> = Pressure increase

