

8300100339

VWA0910BTTRZ

EC axial fan - AxiBlade

sickle-shaped blades (S series)

Fan housing with guide vanes

8300100339 ebmpapst Datasheet

sales@fansco.com

www.fansco.com

Limited partnership · Headquarters Muldingen

Amtsgericht (court of registration) Stuttgart · HRA 590344

General partner Elektrobau Muldingen GmbH · Headquarters Muldingen

Amtsgericht (court of registration) Stuttgart · HRB 590142

Nominal data

Item	8300100339	
Motor	E15031-120	

Phase		3~
Nominal voltage	VAC	400
Nominal voltage range	VAC	380 .. 480
Frequency	Hz	50/60
Method of obtaining data		ml
Speed (rpm)	min ⁻¹	1150-1200
Power consumption	W	3900
Current draw	A	6.0
Max. back pressure	Pa	300
Max. back pressure	in. wg	1.2
Min. ambient temperature	°C	-40
Max. ambient temperature	°C	30

ml = Max. load · me = Max. efficiency · fa = Free air · cs = Customer specification · ce = Customer equipment
Subject to change

Data according to Commission Regulation (EU) 327/2011 (prEN 17166)

		Actual	Req. 2015			
01 Overall efficiency η_{es}	%	58	37.4	09 Power consumption P_{ed}	kW	3.92
02 Measurement category		A		09 Air flow q_v	m ³ /h	26485
03 Efficiency category		Static		09 Pressure increase p_{fs}	Pa	296
04 Efficiency grade N		60.6	40	10 Speed (rpm) n	min ⁻¹	1150
05 Variable speed drive		Yes		11 Specific ratio*		1.00

Data obtained at optimum efficiency level.

* Specific ratio = $1 + p_{fs} / 100\,000\text{ Pa}$

LU-205670

The efficiency values displayed for achieving conformity with the Ecodesign Regulation EU 327/2011 has been reached with defined air duct components (e.g. inlet rings).
The dimensions must be requested from ebm-papst. If other air conduction geometries are used on the installation side, the ebm-papst evaluation loses its validity/the conformity must be confirmed again.
The product does not fall within the scope of Regulation (EU) 2019/1781 due to the exception specified in Article 2 (2a) (motors completely integrated into a product).



8300100339

VWA0910BTTRZ

EC axial fan - AxiBlade

sickle-shaped blades (S series)

Fan housing with guide vanes

Technical description

Weight	53.2 kg
Size	910 mm
Motor size	150
Rotor surface	Painted black
Electronics housing material	Die-cast aluminum, painted gray
Impeller material	PP plastic
Support ring material	Steel, coated with black plastic (RAL 9005)
Fan housing material	Sheet steel, galvanized and coated with black plastic (RAL 9005)
Material guide vanes	PP plastic
Internal diffuser material including cover	PP plastic
Number of blades	5
Blade pitch	0°
Airflow direction	V
Direction of rotation	Clockwise, viewed toward rotor
Degree of protection	IP55
Insulation class	"F"
Moisture (F) / Environmental (H) protection class	H2+A
Ambient temperature note	Occasional start-up at temperatures between -40°C and -25°C is permitted. For continuous operation at ambient temperatures below -25°C (such as refrigeration applications), use must be made of a fan design with special low-temperature bearings.
Max. permitted ambient temp. for motor (transport/storage)	+80 °C
Min. permitted ambient temp. for motor (transport/storage)	-40 °C
Installation position	Shaft horizontal or rotor on top; rotor on bottom on request
Condensation drainage holes	On stator side
Mode	S1
Motor bearing	Ball bearing
Technical features	<ul style="list-style-type: none"> - Operation and alarm display with LED - External 15-50 VDC input (parameterization) - Alarm relay - Integrated PI controller - Configurable inputs/outputs (I/O) - MODBUS V6.3 - Motor current limitation - RS-485 MODBUS-RTU - Soft start - Voltage output 3.3-24 VDC, Pmax = 800 mW - Control interface with SELV potential safely disconnected from the mains - Thermal overload protection for electronics/motor - Line undervoltage / phase failure detection
EMC immunity to interference	According to EN 61000-6-2 (industrial environment)
EMC interference emission	According to EN 61000-6-3 (household environment), except EN 61000-3-2 for professionally used equipment with a total rated power greater than 1 kW
Touch current according to IEC 60990 (measuring circuit Fig. 4, TN system)	<= 3.5 mA



8300100339

VWA0910BTTRZ

EC axial fan - AxiBlade

sickle-shaped blades (S series)

Fan housing with guide vanes

Electrical hookup	Terminal box
Motor protection	Reverse polarity and locked-rotor protection
Protection class assignment	I; If a protective earth is connected by the customer This component for installation may have several local protection classes. This information relates to this component's basic design. The final protection class is based on the component's intended installation and connection.
Conformity with standards	EN 61800-5-1; CE
Approval	UL 1004-7 + 60730-1; CSA C22.2 No. 77 + CAN/CSA-E60730-1; EAC



8300100339

VWA0910BTTRZ

EC axial fan - AxiBlade

sickle-shaped blades (S series)

Fan housing with guide vanes

Product drawing

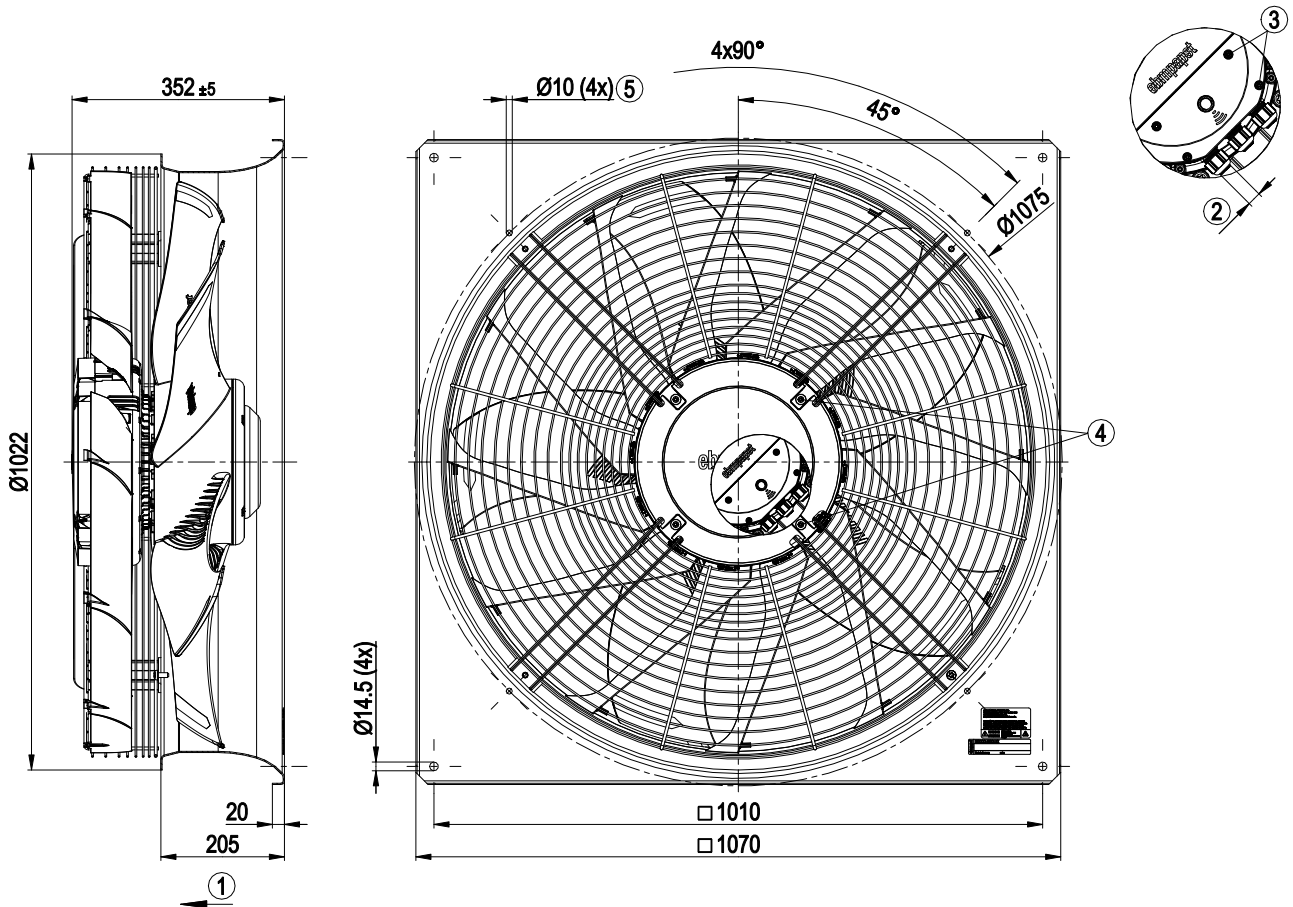

1	Airflow direction "V"
2	Cable diameter min. 4 mm, max. 10 mm, tightening torque 4 ± 0.6 Nm (The tightening torque is designed for PVC cables. If the cable materials are different, the tightening torque may have to be adjusted)
3	Tightening torque 1.5 ± 0.2 Nm
4	Tightening torque 3 ± 0.3 Nm
5	Attachment holes for FlowGrid (91000-2-2957 not included in scope of delivery)



EC axial fan - AxiBlade

sickle-shaped blades (S series)

Fan housing with guide vanes

Connection diagram

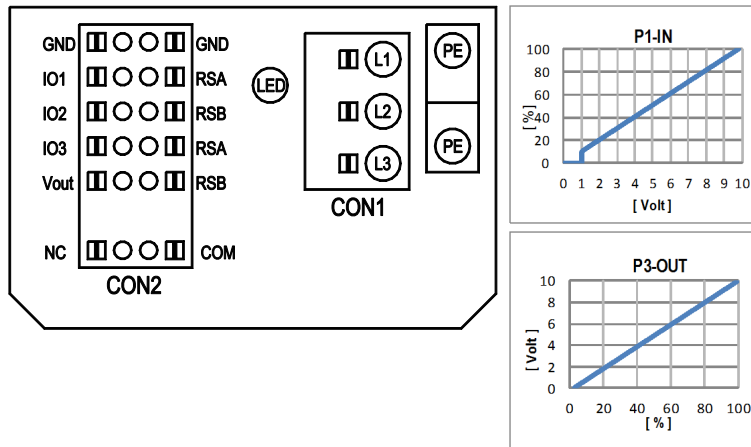

No.	Conn.	Designation	Function/assignment
	CON1	L1, L2, L3	Power supply, phase, see nameplate for voltage range
	PE	PE	Protective earth
	CON2	RSA	RS485 interface for MODBUS, RSA; SELV
	CON2	RSB	RS485 interface for MODBUS, RSB; SELV
	CON2	GND	Reference ground for control interface, SELV
	CON2	IO1	Function parameterizable (see "Optional interface functions" table) Factory setting: Digital input - high active, function: Disable input, SELV - inactive: Pin open or applied voltage < 1.5 VDC - active: applied voltage 3.5-50 VDC Reset function: Triggering of error reset on change of state from "enabled" to "disabled"
	CON2	IO2	Function parameterizable (see "Optional interface functions" table) Factory setting: Analog input 0-10 V / PWM, Ri=100 kΩ, function: Set value Characteristic curve parameterizable (see input characteristic curve P1-IN), SELV
	CON2	IO3	Function parameterizable (see "Optional interface functions" table) Factory setting: Analog output 0-10 V, max. 5 mA, function: Fan modulation level Characteristic curve parameterizable (see output characteristic curve P3-OUT), SELV
	CON2	Vout	Voltage output 3.3-24 VDC ±5%, Pmax=800 mW, voltage parameterizable Factory setting: 10 VDC short-circuit-proof, supply for external devices, SELV alternatively: 15-50 VDC input for parameterization via MODBUS without line voltage
	CON2	COM	Status relay, floating status contact, common connection, contact rating 250 VAC / 2 A (AC1) / min. 10 mA, reinforced insulation on supply side and on control interface side
	CON2	NC	Status relay, floating status contact, break for failure
		LED	green: status = good, ready for operation orange: status = warning red: status = failure
		P1-IN	Input characteristic curve
		P3-OUT	Output characteristic curve

EC axial fan - AxiBlade

sickle-shaped blades (S series)

Fan housing with guide vanes

Terminal/plug assignment

CON2	configurable IO mode	electrical specification	configurable IO functions: normal / inverse	MODBUS Register for IO mode configuration	
				MODBUS Register for IO mode configuration	MODBUS Register for IO mode configuration
IO1	○ Din1 (active high), digital input	active: applied voltage 3.5-50VDC, SELV not active: pin open or applied voltage < 1.5VDC		D158 [0]	
	○ Ain1 0-10V/PWM: analog input	RI = 100k, characteristic curve parameterizable, f _{PWM} = 1k..10kHz, SELV		D158 [2]	
	○ Tach out (open collector output)	U _{max} = 50VDC, I _{max} = 20mA, SELV		D158 [5]	
	○ Diagnostics out (open collector output)	U _{max} = 50VDC, I _{max} = 20mA, SELV		D158 [6]	
IO2	○ Din2 (active high), digital input	active: applied voltage 3.5-50VDC, SELV not active: pin open or applied voltage < 1.5VDC		D159 [0]	
	○ Ain2 0-10V/PWM: analog input	RI = 100k, characteristic curve parameterizable, f _{PWM} = 1k..10kHz, SELV		D159 [2]	
	○ Ain2 4-20mA: analog input	RI = 125R, characteristic curve parameterizable, SELV		D159 [3]	
	○ Din3 (active high), digital input	active: applied voltage 3.5-50VDC, SELV not active: pin open or applied voltage < 1.5VDC		D15A [0]	
IO3	○ Din3 (active low), digital input	active: applied voltage < 1.5VDC, SELV not active: pin open or applied voltage 3.5-50VDC		D15A [1]	
	○ PWMIn3: digital input, idle level high	PWM = 40Hz - 10kHz, characteristics parameterizable active: pin open or applied voltage 3.5-50VDC not active: applied voltage < 1.5VDC, SELV		D15A [7]	
	○ PWMIn3: digital input, idle level low	active: applied voltage 3.5-50VDC not active: pin open or applied voltage < 1.5VDC, SELV		D15A [8]	
	○ Aout3 0-10V: analog output	function parameterizable, max. 5mA max output frequency 300Hz, SELV		D15A [4]	
RSA	○ Tacho out (pulses), analog output	0-10V/max. 5mA max output frequency 300Hz, SELV		D15A [5]	
	○ Diagnostics out (pulses)	0-10V/max. 5mA max output frequency 300Hz, SELV		D15A [6]	
	○ RSA	MODBUS RTU, specification V6.3, SELV			
RSB	RS485 bus connection,				
Vout	voltage output	voltage parameterizable 3.3..24VDC +/- 5%, P _{max} =800mW, short-circuit-proof, supply for external devices, SELV		D16E [..]	
	alternatively: Input auxiliary power supply for parameterization via RS485/MODBUS RTU without line voltage	15..50VDC			

○ configurable option

For further information and additional functions see EC Control Software, Fan-Set-App, or MODBUS Parameter Specification V6.3



8300100339

VWA0910BTTRZ

EC axial fan - AxiBlade

sickle-shaped blades (S series)

Fan housing with guide vanes

Curves: Air performance 50 Hz

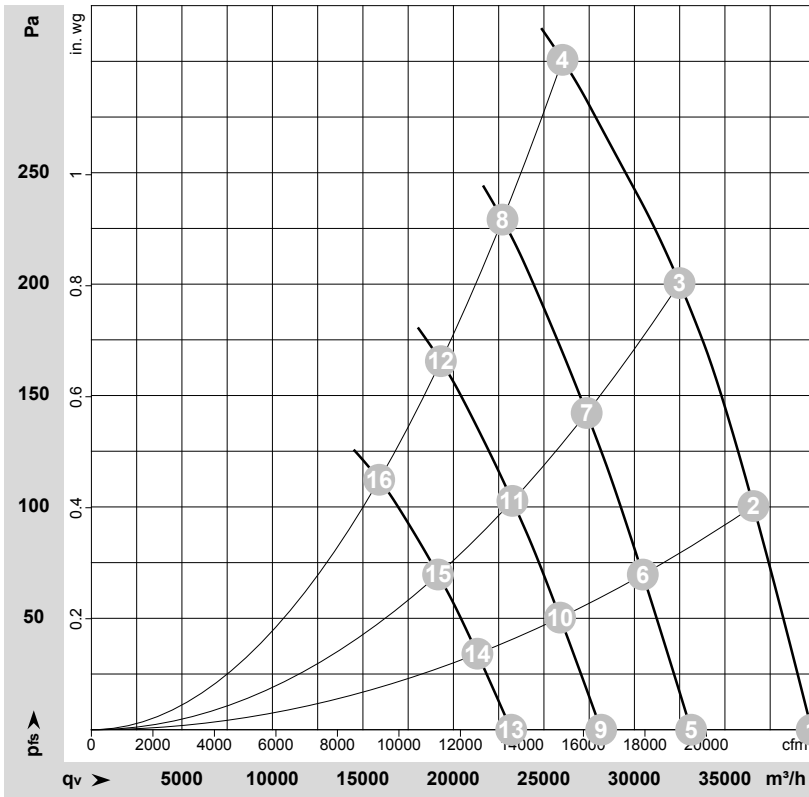

$\rho = 1.15 \text{ kg/m}^3 \pm 2 \%$

Measurement: LU-205670-1

Air performance measured according to ISO 5801 installation category A. For detailed information on the measurement setup, contact ebmpapst. Intake sound level: Sound power level according to ISO 13347 / sound pressure level measured at 1 m distance from fan axis. The values given are valid under the specified measuring conditions and may vary due to conditions of installation. For deviations from the standard configuration, the parameters have to be checked on the installed unit.

Measured values

	Wired	U	f	n	P _e	I	LpA _{in}	LwA _{in}	LwA _{out}	q _v	p _{fs}	q _v	p _{fs}
		V	Hz	min ⁻¹	W	A	dB(A)	dB(A)	dB(A)	m ³ /h	Pa	cfm	in. wg
1	3~	400	50	1200	3008	4.62	77	85	87	39795	0	23420	0.00
2	3~	400	50	1200	3573	5.47	76	84	85	36575	100	21530	0.40
3	3~	400	50	1190	3907	5.96	76	85	85	32495	200	19125	0.80
4	3~	400	50	1150	3900	6.00	81	89	89	26030	300	15320	1.20
5	3~	400	50	1000	1737	2.66	73	80	82	33135	0	19500	0.00
6	3~	400	50	1000	2049	3.14	71	79	81	30465	71	17930	0.29
7	3~	400	50	1000	2326	3.55	72	80	81	27360	143	16105	0.57
8	3~	400	50	1000	2607	3.98	78	85	86	22715	229	13370	0.92
9	3~	400	50	850	1066	1.64	68	76	78	28165	0	16575	0.00
10	3~	400	50	850	1258	1.93	67	75	77	25895	51	15240	0.20
11	3~	400	50	850	1428	2.18	68	76	77	23260	103	13690	0.41
12	3~	400	50	850	1601	2.44	74	81	82	19305	166	11365	0.67
13	3~	400	50	700	596	0.91	64	71	73	23195	0	13650	0.00
14	3~	400	50	700	703	1.08	62	70	72	21325	35	12550	0.14
15	3~	400	50	700	798	1.22	63	71	72	19155	70	11275	0.28
16	3~	400	50	700	894	1.36	69	76	77	15900	112	9360	0.45

Wired = Wiring · U = Voltage · f = Frequency · n = Speed (rpm) · P_e = Power consumption · I = Current draw · LpA_{in} = Sound pressure level intake side · LwA_{in} = Sound power level intake side
 LwA_{out} = Sound power level outlet side · q_v = Air flow · p_{fs} = Pressure increase

