

Product Data Sheet **9695490182**
VUCG140AKLPS
5318/2HP

5318/2HP (9695490182) ebmpapst Datasheet
sales@fansco.com www.fansco.com

ebmpapst

engineering a better life



5318/2HP

INDEX

- 1 General 3**
- 2 Mechanics 3**
 - 2.1 General 3
 - 2.2 Connections 3
- 3 Operating Data 4**
 - 3.1 Electrical Interface - Input 4
 - 3.2 Electrical Operating Data 5
 - 3.3 Electrical Interface - Output 6
 - 3.4 Electrical Features 7
 - 3.5 Aerodynamics 8
 - 3.6 Sound Data 9
- 4 Environment 9**
 - 4.1 General 9
 - 4.2 Climatic Requirements 10
- 5 Safety 11**
 - 5.1 Electrical Safety 11
 - 5.2 Approval Tests 11
- 6 Reliability 11**
 - 6.1 General 11

1 General

Fan type	Axial-Panel-Fan	
Rotating direction looking at rotor	Counterclockwise	
Airflow direction	Air intake over struts	
Bearing system	Ball bearing	
Mounting position - shaft	Any	

2 Mechanics

2.1 General

Width	140,0 mm	
Height	140,0 mm	
Depth	51,0 mm	
Mass	0,900 kg	
Housing material	Metal	
Impeller material	Plastic	
Max. torque when mounted across both mounting flanges	Wire outlet corner: 440 Ncm Remaining corners: 600 Ncm	
Screw size	ISO 4762 - M4 degreased, without an additional brace and without washer	

2.2 Connections

Electrical connection	Wires	
Lead wire length	L = 310 mm	
Tolerance	+/- 10,0 mm	

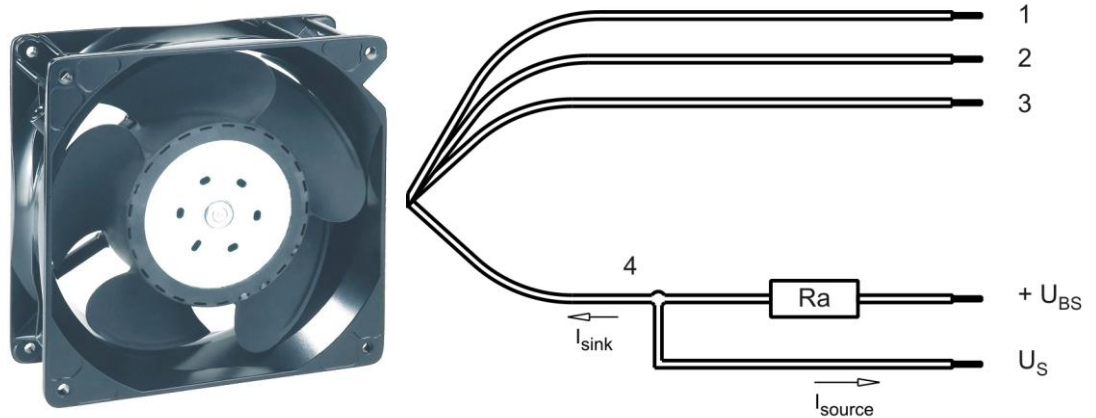

Wire	Color	Operation	Wire size	Insulation diameter
1	red	+ UB	AWG 22	1,7 mm
2	blue	- GND	AWG 22	1,7 mm
3	violet	PWM	AWG 22	1,7 mm
4	white	Tacho	AWG 22	1,7 mm

The auxiliaries shown on the schematic diagram (which are required for the intended use) are not part of our delivery.

3 Operating Data

3.1 Electrical Interface - Input

Control input	PWM
---------------	-----

Features

Input type	Open collector	
PWM - Frequency		1 kHz - 20 kHz typical: 2 kHz

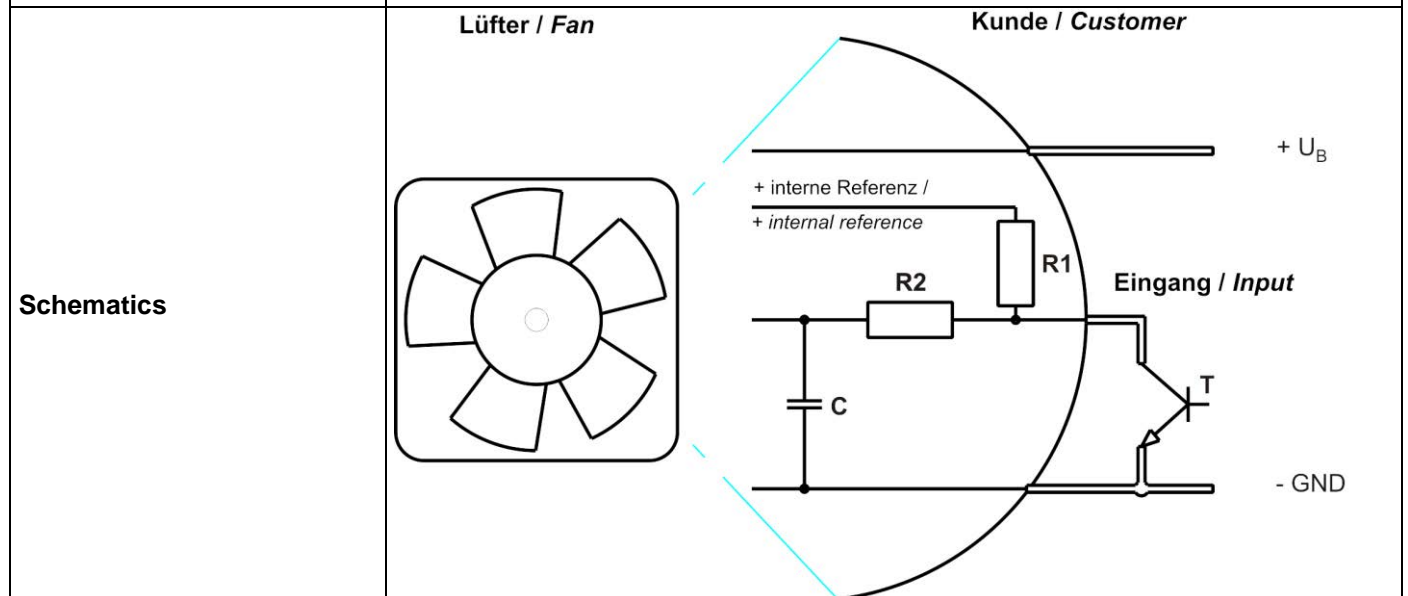
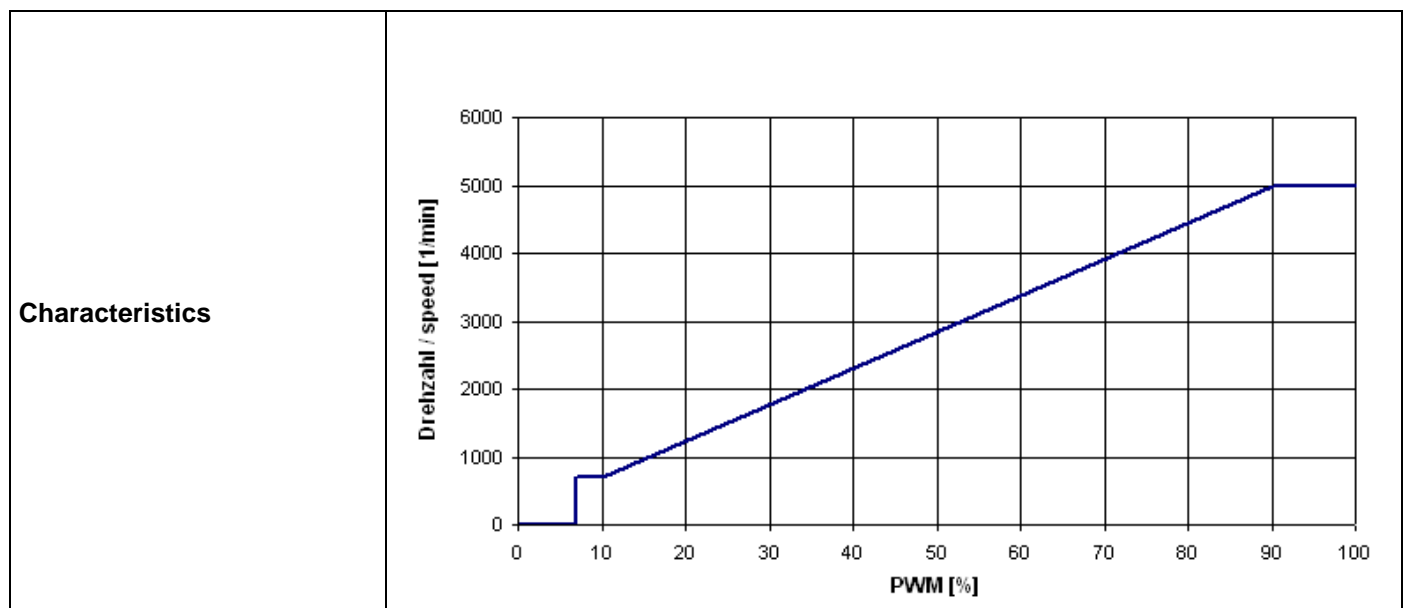

The shown pull-up resistor R1 to the internal reference voltage (+5V) has 4.7kOhm.

Transistor requirements:

VCE max. >= 12V ; Isink max > 5mA ; VCEsat < 0,15V

3.2 Electrical Operating Data

Measurement conditions: Normal air density = 1,2 kg/m³; Temperature 23°C +/- 3°C; Motor axis horizontal; warm-up time before measuring 5 minutes (unless otherwise specified). In the intake and outlet area should not be any solid obstruction within 0,5 m.

$\Delta p = 0$: corresp. to free air flow (see chapter aerodynamics)
I: corresp. to arithm. mean current value

Name	Condition
PWM 0001	PWM: 100 %; f: 2 kHz

Features	Condition	Symbol	Values		
Voltage range		U	36 V		72 V
Nominal voltage		U _N		48,0 V	
Power consumption	$\Delta p = 0$	P	19,8 W	27 W	28,5 W
Tolerance	PWM 0010		+/- 20 %	+/- 10 %	+/- 15 %
Current consumption	$\Delta p = 0$	I	550 mA	550 mA	395 mA
Tolerance	PWM 0010		+/- 20 %	+/- 10 %	+/- 15 %
Speed	$\Delta p = 0$	n	4.300 1/min	5.000 1/min	5.000 1/min
Tolerance	PWM 0010		+/- 10 %	+/- 5 %	+/- 5 %
Starting current consumption				1.200 mA	

3.3 Electrical Interface - Output

Tacho type	/2 (open collector)
------------	---------------------

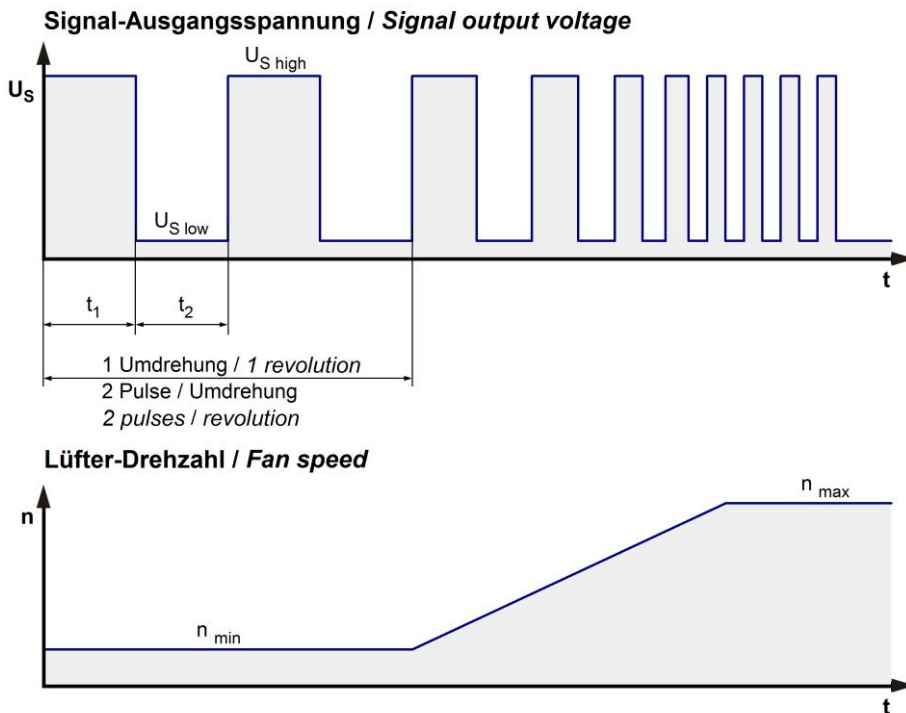

$$R_a = \frac{U_{BS} - U_{S\ low}}{I_{sink}}$$

Lüfter / Fan Kunde / Customer

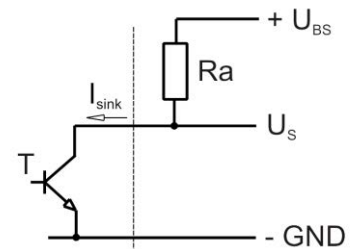

Features	Note	Values
Tacho operating voltage	U_{BS}	$\leq 60\ V$
Tacho signal Low	$U_{S\ low}$	$\leq 0,4\ V$
Tacho signal High	$U_{S\ high}$	$\leq 60\ V$
Maximum sink current	I_{sink}	20 mA
External resistor	External resistor R_a from U_{BS} to U_S required. All voltages measured to GND.	
Tacho frequency	$(2 \times n) / 60$	167 Hz @ 5.000 1/min
Tacho isolated from motor	No	
Slew rate		$\geq 0,5\ V/\mu s$

n = revolutions per minute (1/min)

3.4 Electrical Features

Electronic function	Speed-Controlled	
Reversed polarity protection	Rectifying diode	
Max. residual current at U_N	$I_F \leq 1 \text{ mA}$	
Locked rotor protection	Auto restart	
Locked rotor current at U_N	I_{block} approx. 1.400 mA	
Clock signal at locked rotor	t_3 / t_4 typical: 0,5 s / 5,0 s	
Internal fuse	Littelfuse NANO2 > Very Fast-Acting > 451/453 Series 2A / 125V (Art.No.: 0451002.MRL)	

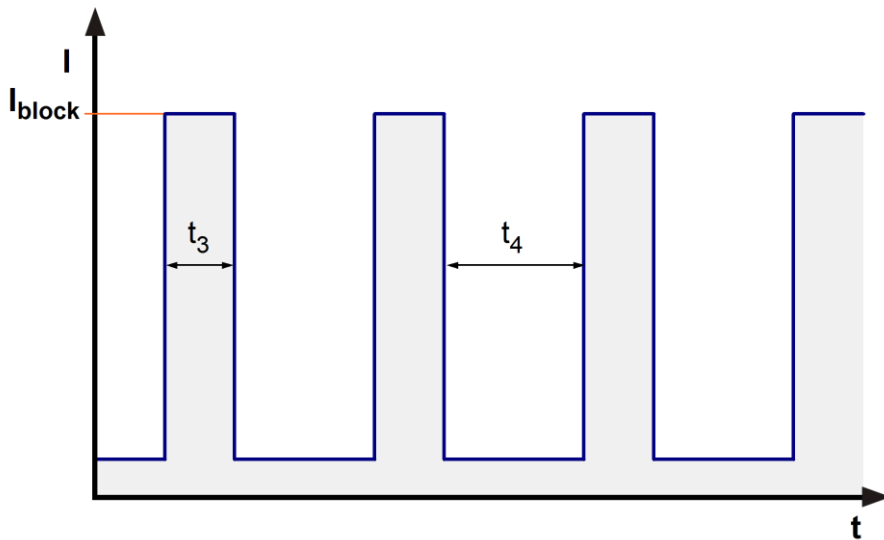

Max. current when decelerate at U_{nom} . approx 3.000 mA peak.

3.5 Aerodynamics

Measurement conditions: Measured with a double chamber intake rig acc. to DIN EN ISO 5801. Normal air density = 1,2 kg/m³; Temperature 23°C +/- 3°C; In the intake and outlet area should not be any solid obstruction within 0,5 m. Motor shaft horizontal. The information is only valid under the specified test conditions and may be changed by the installation conditions. If there are deviations from the standard test conditions, the characteristic values must be checked under the installed conditions.

a.) Operation condition:

5.000 1/min at free air flow	PWM 100 %; f: 2 kHz		
------------------------------	---------------------	--	--

Max. free-air flow ($\Delta p = 0 / \dot{V} = \text{max.}$)	340 m ³ /h	
Max. static pressure ($\Delta p = \text{max.} / \dot{V} = 0$)	345 Pa	

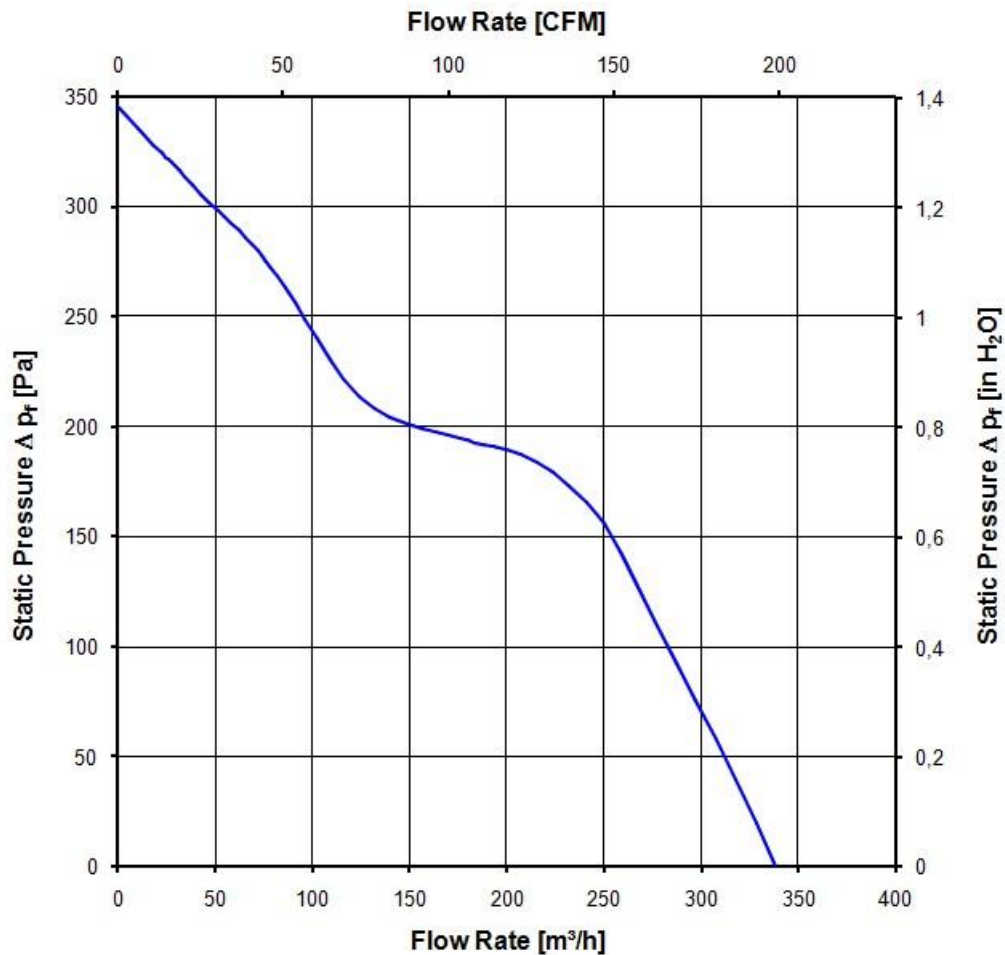

3.6 Sound Data

Measurement conditions: Sound pressure level: 1 meter distance between microphone and the air intake.
 Sound power level: Acc. to DIN 45635 part 38 (ISO 10302)
 Measured in a semianechoic chamber with a background noise level of $L_p(A) < 5 \text{ dB(A)}$
 For further measurement conditions see chapter aerodynamics.

a.) Operation condition:

5.000 1/min at free air flow	PWM 100 %; f: 2 kHz		
------------------------------	---------------------	--	--

Optimal operating point	220 m ³ /h @ 160 Pa		
Sound power level at the optimal operating point	7,2 bel(A)		
Sound pressure level at free air flow, measured in rubber bands	64,0 dB(A)		

4 Environment

4.1 General

Min. permitted ambient temperature TU min.	-20 °C		
Max. permitted ambient temperature TU max.	65 °C		
Min. permitted storage temperature TL min.	-40 °C		
Max. permitted storage temperature TL max.	80 °C		

4.2 Climatic Requirements

Humidity requirements	humid heat, constant; according to DIN EN 60068-2-78, 14 days	
Water exposure	None	
Dust requirements	None	
Salt fog requirements	None	

Permitted application area:

The product is intended for use in sheltered rooms with controlled temperature and controlled humidity. Directly exposure to water must be avoided.

Pollution degree 1 (according DIN EN 60664-1)

There is either no pollution or it occurs only dry, non-conductive pollution. The pollution has no negative impact.

Please require severity levels and specification parameters from the responsible development departments.

5 Safety

5.1 Electrical Safety

Dielectric strength DIN EN 62368 and DIN EN 60335 A.) Type test Measuring conditions: After 48h of storage at 95% R.H. and 25°C. No arcing or breakdown is allowed! All connections together to ground. B.) Routine test Measuring conditions: At indoor climate. No arcing or breakdown is allowed! All connections together to ground.	1000 VAC / 1 Min. 1700 VDC / 1 Sec.	
Isolation resistance Measuring conditions: After 48h of storage at 95% R.H. and 25°C measured with U=500 VDC for 1 min.	RI > 10 MOhm	
Clearance / creepage distance	1,0 mm / 1,5 mm	
Protection class	I	

5.2 Approval Tests

CE	EC Declaration of Conformity	Yes
UKCA	UK Conformity Assessed	Not applicable
EAC	Eurasian Conformity	Yes
America	UL - Underwriters Laboratories	Yes / UL audited by CSA according to UL507, Electric Fans
Europe	VDE - Association for Electrical or UL - Underwriters Laboratories or comparable	Yes / Approval acc. to EN 62368 - Audio/video, information and communication technology equipment
Canada	UL - Underwriters Laboratories or CSA - Canadian Standards Association	Yes / C22.2 No. 113 Fans and Ventilators
China	CCC - China Compulsory Certification or CQC - China Quality Certification	Yes / GB 12350 Safety Requirements for small Power Motors

6 Reliability

6.1 General

Life expectancy L10 at TU = 40 °C	77.500 h	
Life expectancy L10 at TU max.	40.000 h	
Life expectancy L10 acc. to IPC 9591 at TU = 40 °C	130.000 h	

CAD 3D of this drawing, the drawing is shown as the 3D model. The drawing is not a 3D model. The drawing is not a 3D model. The drawing is not a 3D model.

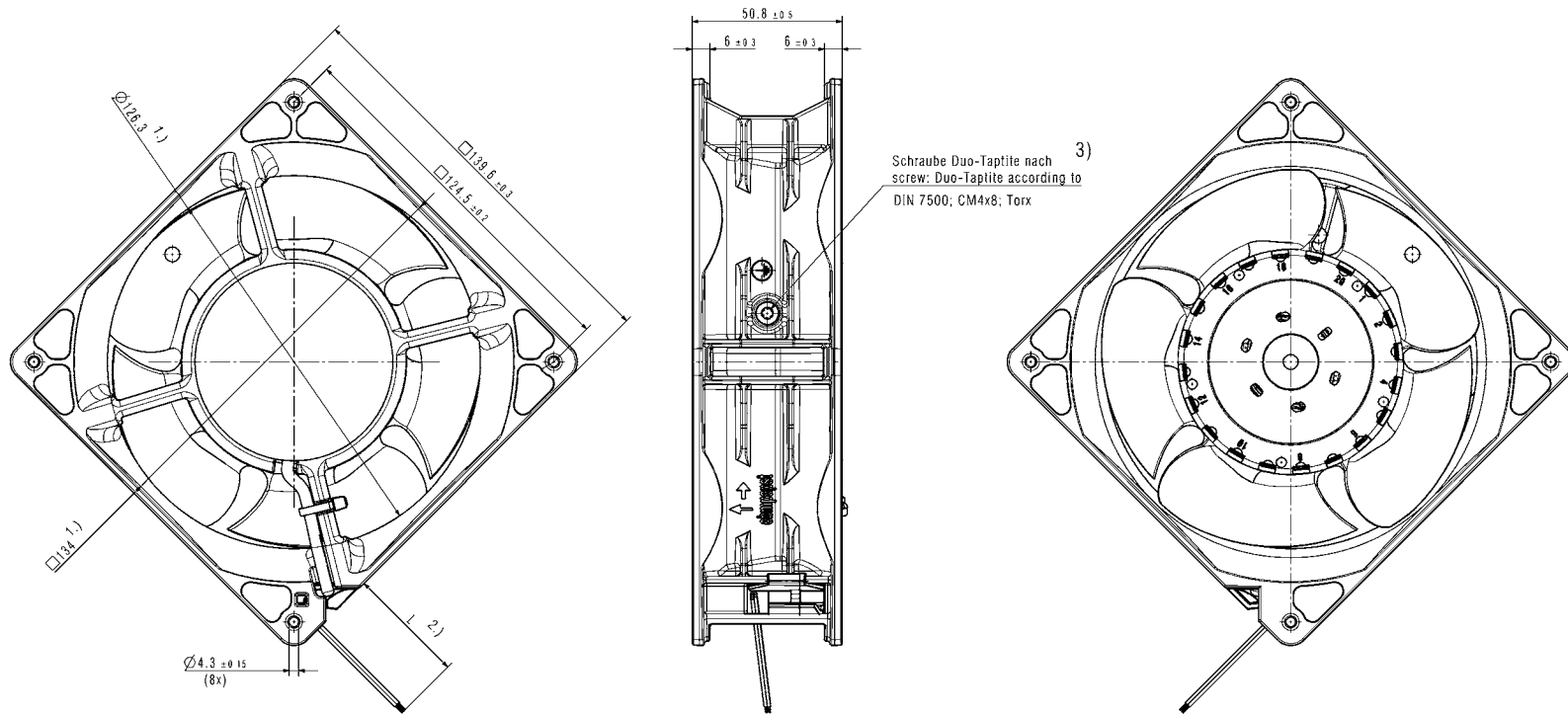

- 1.) Maße aus Montageauschnitt
- 2.) Anzahl und Länge der Litzen siehe Produktspezifikation
- 3.) nur wenn in Stückliste enthalten

- Axialspiel der Kugellager mit Feder spielfrei gelagert

- 1.) measures of mounting cut out
- 2.) length an number of wires see product specification
- 3.) only it is included in bill of material

- ball bearing without clearance by a pre-load spring

Zeichnung entspricht 3D-Modell:
 Drawing is equivalent to 3D-Model:
 9695490181_CPR_000 -
 System: CATIA V5 R 16

SP-Drehzahl/Rev/min		Anzahl Polpaare		Drehmoment / Nm		Leistung / kW		Effizienz / %	
Drehmoment / Nm		Leistung / kW		Effizienz / %		Drehmoment / Nm		Leistung / kW	
Drehmoment / Nm		Leistung / kW		Effizienz / %		Drehmoment / Nm		Leistung / kW	
Drehmoment / Nm		Leistung / kW		Effizienz / %		Drehmoment / Nm		Leistung / kW	
Drehmoment / Nm		Leistung / kW		Effizienz / %		Drehmoment / Nm		Leistung / kW	