

251657216

Product Data Sheet

8315100050
VUC0140AULCS
5314/2HPU-050

ebmpapst

The engineer's choice



5314/2HPU-050

INDEX

- 1 General 3**
- 2 Mechanics 3**
 - 2.1 General..... 3
 - 2.2 Connections..... 3
- 3 Operating Data 4**
 - 3.1 Electrical Interface - Input..... 4
 - 3.2 Electrical Operating Data 5
 - 3.3 Electrical Interface - Output..... 6
 - 3.4 Electrical Features 7
 - 3.5 Aerodynamics 8
 - 3.6 Sound Data..... 9
- 4 Environment..... 9**
 - 4.1 General..... 9
 - 4.2 Climatic Requirements 10
- 5 Safety..... 11**
 - 5.1 Electrical Safety 11
 - 5.2 Approval Tests 11
- 6 Reliability..... 11**
 - 6.1 General..... 11

1 General

| | | |
|-------------------------------------|------------------------|--|
| Fan type | Fan | |
| Rotating direction looking at rotor | Counterclockwise | |
| Airflow direction | Air intake over struts | |
| Bearing system | Ball bearing | |
| Mounting position - shaft | Any | |

2 Mechanics

2.1 General

| | | |
|---|---|--|
| Width | 140,0 mm | |
| Height | 140,0 mm | |
| Depth | 51,0 mm | |
| Mass | 0,900 kg | |
| Housing material | Metal | |
| Impeller material | Plastic | |
| Max. torque when mounted across both mounting flanges | Wire outlet corner: 440 Ncm Remaining corners: 600 Ncm | |
| Screw size | ISO 4762 - M4 degreased, without an additional brace and without washer | |

2.2 Connections

| | | |
|-----------------------|-------------|--|
| Electrical connection | Wires | |
| Lead wire length | L = 310 mm | |
| Tolerance | + - 10,0 mm | |
| Tube length | S = 0 mm | |
| Tolerance | | |

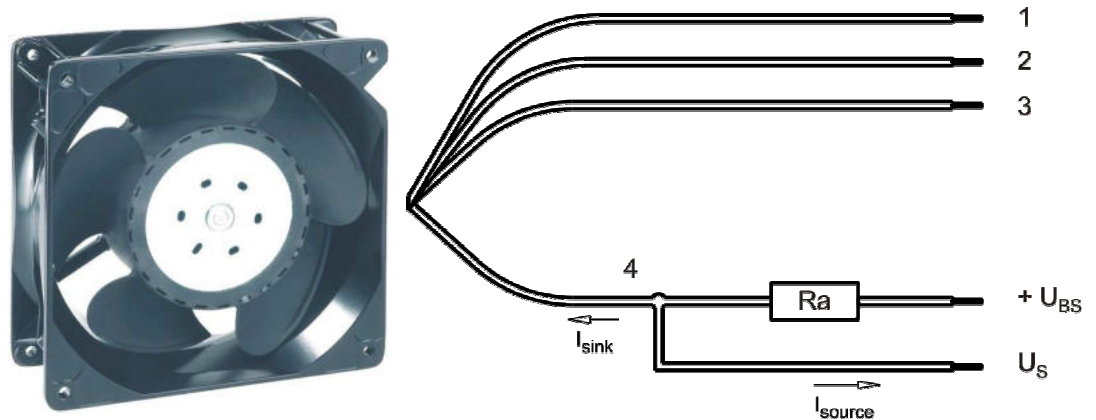

| Wire | Color | Operation | Wire size | Insulation diameter |
|------|--------|-----------|-----------|---------------------|
| 1 | red | + UB | AWG 22 | 1,7 mm |
| 2 | blue | - GND | AWG 22 | 1,7 mm |
| 3 | violet | PWM | AWG 22 | 1,7 mm |
| 4 | white | Tacho | AWG 22 | 1,7 mm |

The auxiliaries shown on the schematic diagram (which are required for the intended use) are not part of our delivery.

3 Operating Data

3.1 Electrical Interface - Input

| | |
|---------------|-----|
| Control input | PWM |
|---------------|-----|

Features

| | | |
|-----------------|----------------|----------------------------------|
| Input type | Open collector | |
| PWM - Frequency | | 1 kHz - 20 kHz typical: 2 kHz |

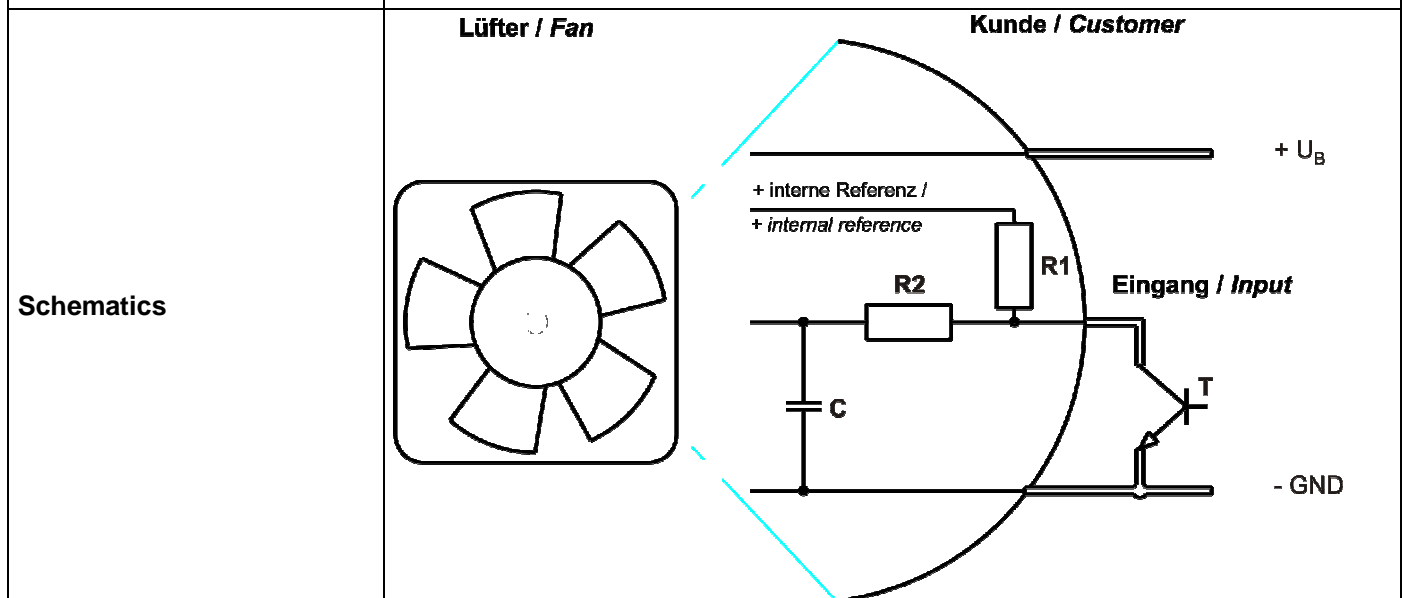
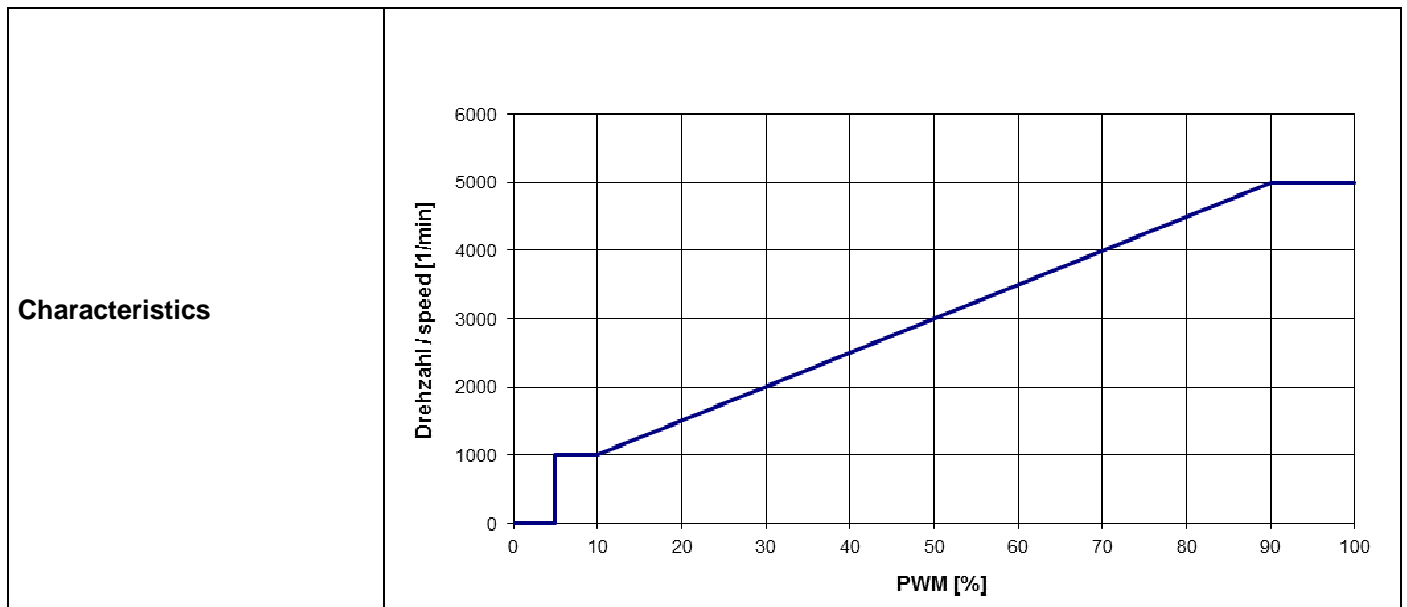

3.2 Electrical Operating Data

Measurement conditions: Normal air density = 1,2 kg/m³; Temperature 23°C +/- 3°C; Motor axis horizontal; warm-up time before measuring 5 minutes (unless otherwise specified). In the intake and outlet area should not be any solid obstruction within 0,5 m.

$\Delta p = 0$: corresp. to free air flow (see chapter aerodynamics)
I: corresp. to arithm. mean current value

| Name | Condition |
|----------|---------------------|
| PWM 0001 | PWM: 95 %; f: 2 kHz |

| Features | Condition | Symbol | Values | | |
|---------------------|----------------|----------------|-------------|-------------|-------------|
| Voltage range | | U | 12,0 V | | 32,0 V |
| Nominal voltage | | U _N | | 24,0 V | |
| Power consumption | $\Delta p = 0$ | P | 10,5 W | 26,5 W | 26,5 W |
| Tolerance | PWM 0010 | | +/- 10,0 % | +/- 10,0 % | +/- 10,0 % |
| Current consumption | $\Delta p = 0$ | I | 860 mA | 1.100 mA | 850 mA |
| Tolerance | PWM 0010 | | +/- 10,0 % | +/- 10,0 % | +/- 10,0 % |
| Speed | $\Delta p = 0$ | n | 3.200 1/min | 5.000 1/min | 5.000 1/min |
| Tolerance | PWM 0010 | | +/- 7,5 % | +/- 5,0 % | +/- 5 % |

3.3 Electrical Interface - Output

| | |
|------------|---------------------|
| Tacho type | /2 (open collector) |
|------------|---------------------|

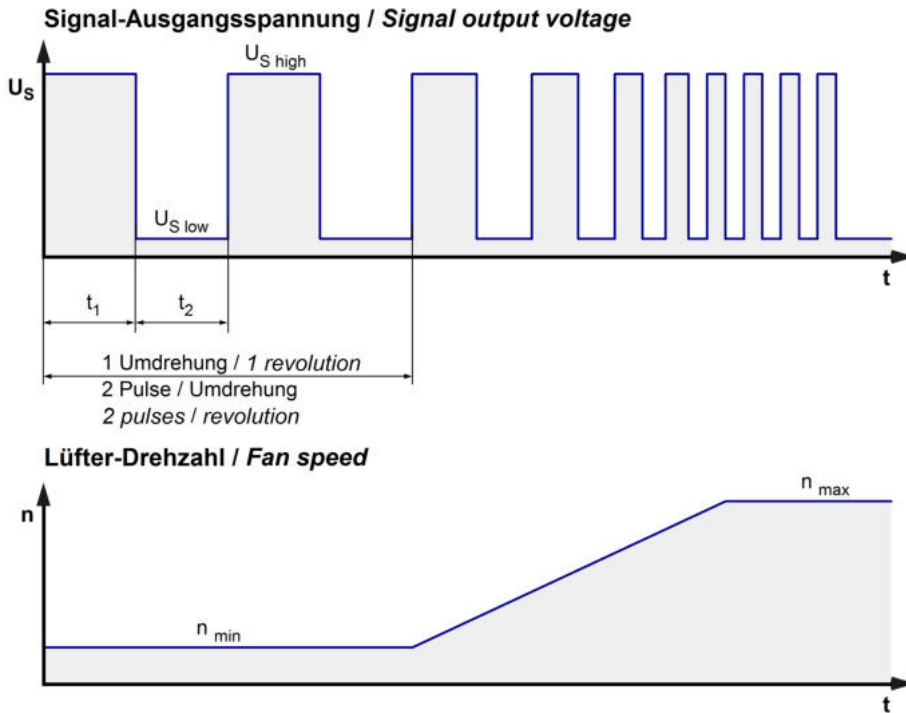

$$R_a = \frac{U_{BS} - U_{S\ low}}{I_{sink}}$$

Lüfter / Fan Kunde / Customer

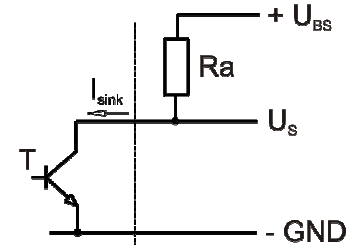

| Features | Note | Values |
|---------------------------|--|----------------------------|
| Tacho operating voltage | U_{BS} | $\leq 32\ V$ |
| Tacho signal Low | $U_{S\ low}$ | $\leq 0,4\ V$ |
| Tacho signal High | $U_{S\ high}$ | $\leq 32\ V$ |
| Maximum sink current | I_{sink} | $\leq 20\ mA$ |
| External resistor | External resistor R_a from U_{BS} to U_S required. All voltages measured to GND. | |
| Tacho frequency | $(2 \times n) / 60$ | |
| Tacho isolated from motor | No | |
| Slew rate | | $\Rightarrow 0,5\ V/\mu s$ |

n = revolutions per minute (1/min)

3.4 Electrical Features

| | | |
|--------------------------------|-----------------------------------|--|
| Electronic function | Speed-Controlled | |
| Reversed polarity protection | Rectifying diode | |
| Max. residual current at U_N | $I_F \leq 5 \text{ mA}$ | |
| Locked rotor protection | Auto restart | |
| Locked rotor current at U_N | I_{block} | |
| Clock signal at locked rotor | t_3 / t_4 typical: 0,5 s / 10 s | |

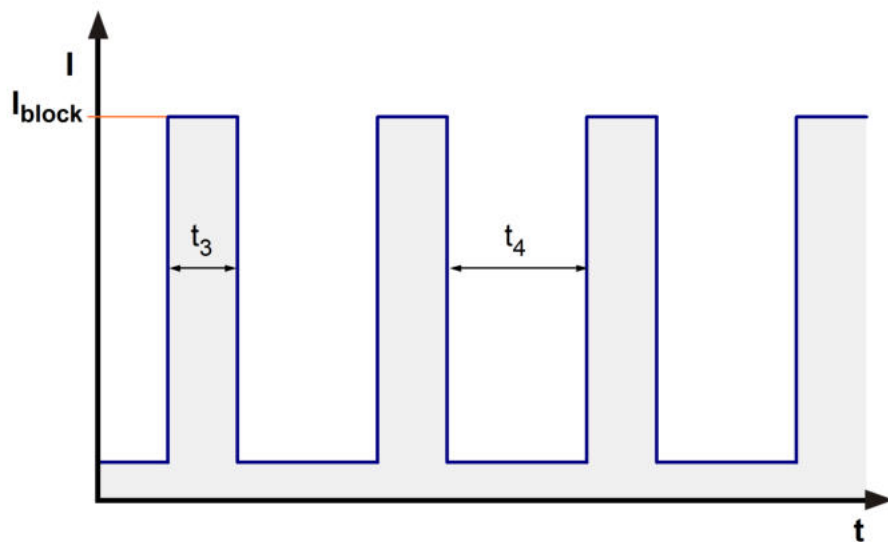

3.5 Aerodynamics

Measurement conditions: Measured with a double chamber intake rig acc. to DIN EN ISO 5801. Normal air density = 1,2 kg/m³; Temperature 23°C +/- 3°C; In the intake and outlet area should not be any solid obstruction within 0,5 m. Motor shaft horizontal. The information is only valid under the specified test conditions and may be changed by the installation conditions. If there are deviations from the standard test conditions, the characteristic values must be checked under the installed conditions. Power consumption of the fan motor when operating at normal voltage is shown. Depending on the operating conditions of the application, the power input may be higher.

a.) Operation condition:

| | | | |
|------------------------------|--------------------|--|--|
| 5.000 1/min at free air flow | PWM 95 %; f: 2 kHz | | |
|------------------------------|--------------------|--|--|

| | | |
|---|-----------------------|--|
| Max. free-air flow ($\Delta p = 0 / \dot{V} = \text{max.}$) | 330 m ³ /h | |
| Max. static pressure ($\Delta p = \text{max.} / \dot{V} = 0$) | 390 Pa | |

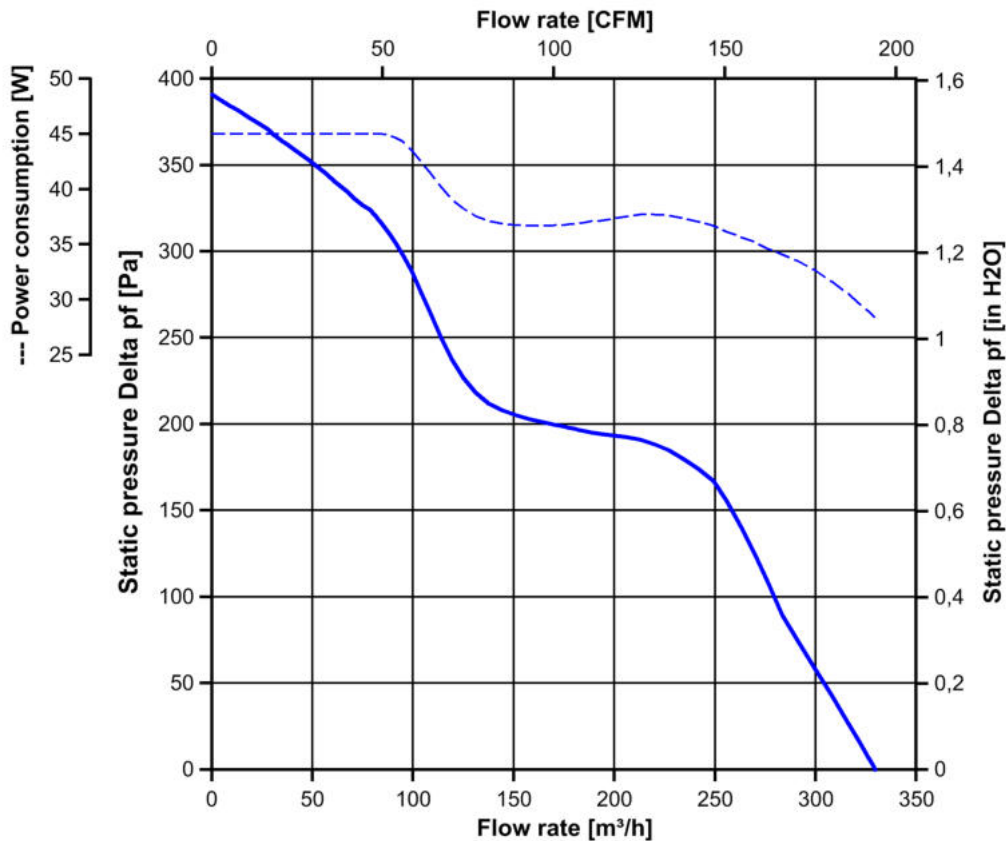

3.6 Sound Data

Measurement conditions: Sound pressure level: 1 meter distance between microphone and the air intake.
Sound power level: Acc. to DIN 45635 part 38 (ISO 10302)
Measured in a semianchoic chamber with a background noise level of $L_p(A) < 5 \text{ dB(A)}$
For further measurement conditions see chapter aerodynamics.

a.) Operation condition:

| | | | |
|------------------------------|--------------------|--|--|
| 5.000 1/min at free air flow | PWM 95 %; f: 2 kHz | | |
|------------------------------|--------------------|--|--|

| | | |
|---|----------------------------------|--|
| Optimal operating point | 240,0 m ³ /h @ 160 Pa | |
| Sound power level at the optimal operating point | 7,2 bel(A) | |
| Sound pressure level at free air flow, measured in rubber bands | 64 dB(A) | |

4 Environment

4.1 General

| | | |
|--|--------|--|
| Min. permitted ambient temperature TU min. | -20 °C | |
| Max. permitted ambient temperature TU max. | 65 °C | |
| Min. permitted storage temperature TL min. | -40 °C | |
| Max. permitted storage temperature TL max. | 80 °C | |

4.2 Climatic Requirements

| | | |
|--------------------------------|---|--|
| IP-protection type (certified) | IP 68 (for fan only, not for connector if applicable) **) | |
| Humidity requirements | humid temperature, cyclic; according to DIN EN 60068-2-38, 10 cycle and condensation water check; according to DIN EN ISO 6270-2, 14 days | |
| Salt fog requirements | None | |

Permitted application area:

The product is for the use in partial sheltered rooms or open, roofed areas. Direct exposure to water is allowed provided that this does not prevent the normal operation. Saline ambient conditions must be avoided.

Pollution degree 3 (according DIN EN 60664-1)

It occurs conductive pollution or dry non-conductive pollution which becomes conductive due to condensation.

**) The specification of the IP protection refers to the conditions mentioned in certification of the fan. The above mentioned short description of the protection scope is not final. For detailed information of the respective protection scope and definitions, see certification as well as DIN EN 60529 (protection by housings) and ISO 20653 (for vehicles) with the letter K.

Short description of the IP-protection type:

Solid particle Protection: Dust tight.

Protection against deliberate contact: Protected against contact to hazardous parts with a wire.

Protection against water: The fan test according to IP68 (Based on IEC 60529), is conducted in non-operating mode. The fan is tested by a complete immersion in water for a period of 2h at a water-level of 1,2m. Electrical connections are not immersed since they are customer specific.

Please require severity levels and specification parameters from the responsible development departments.

5 Safety**5.1 Electrical Safety**

| | | |
|---|--|--|
| Dielectric strength DIN EN 62368 and DIN EN 60335 A.) Type test Measuring conditions: After 48h of storage at 95% R.H. and 25°C. No arcing or breakdown is allowed! All connections together to ground. B.) Routine test Measuring conditions: At indoor climate. No arcing or breakdown is allowed! All connections together to ground. | 500 VAC / 1 Min. 850 VDC / 1 Sec. | |
| Isolation resistance Measuring conditions: After 48h of storage at 95% R.H. and 25°C measured with U=500 VDC for 1 min. | RI > 10 MOhm | |
| Clearance / creepage distance | 1,0 mm / 1,2 mm | |
| Protection class | III | |

5.2 Approval Tests

| | | |
|-----|---|---|
| CE | EC Declaration of Conformity | Yes |
| EAC | Eurasian Conformity | Yes |
| UL | Underwriters Laboratories | Yes / UL507, Electric Fans E38324 |
| VDE | Association for Electrical, Electronic and Information Technologies | Yes / Approval acc. to EN 62368 - Audio/video, information and communication technology equipment |
| CSA | Canadian Standards Association | Yes / CSA audited by UL according to C22.2 No. 113 Fans and Ventilators |
| CCC | China Compulsory Certification | Not applicable |

6 Reliability**6.1 General**

| | | |
|--|-----------|--|
| Life expectancy L10 at TU = 40 °C | 77.500 h | |
| Life expectancy L10 at TU max. | 40.000 h | |
| Life expectancy L10 acc. to IPC 9591 at TU = 40 °C | 130.000 h | |

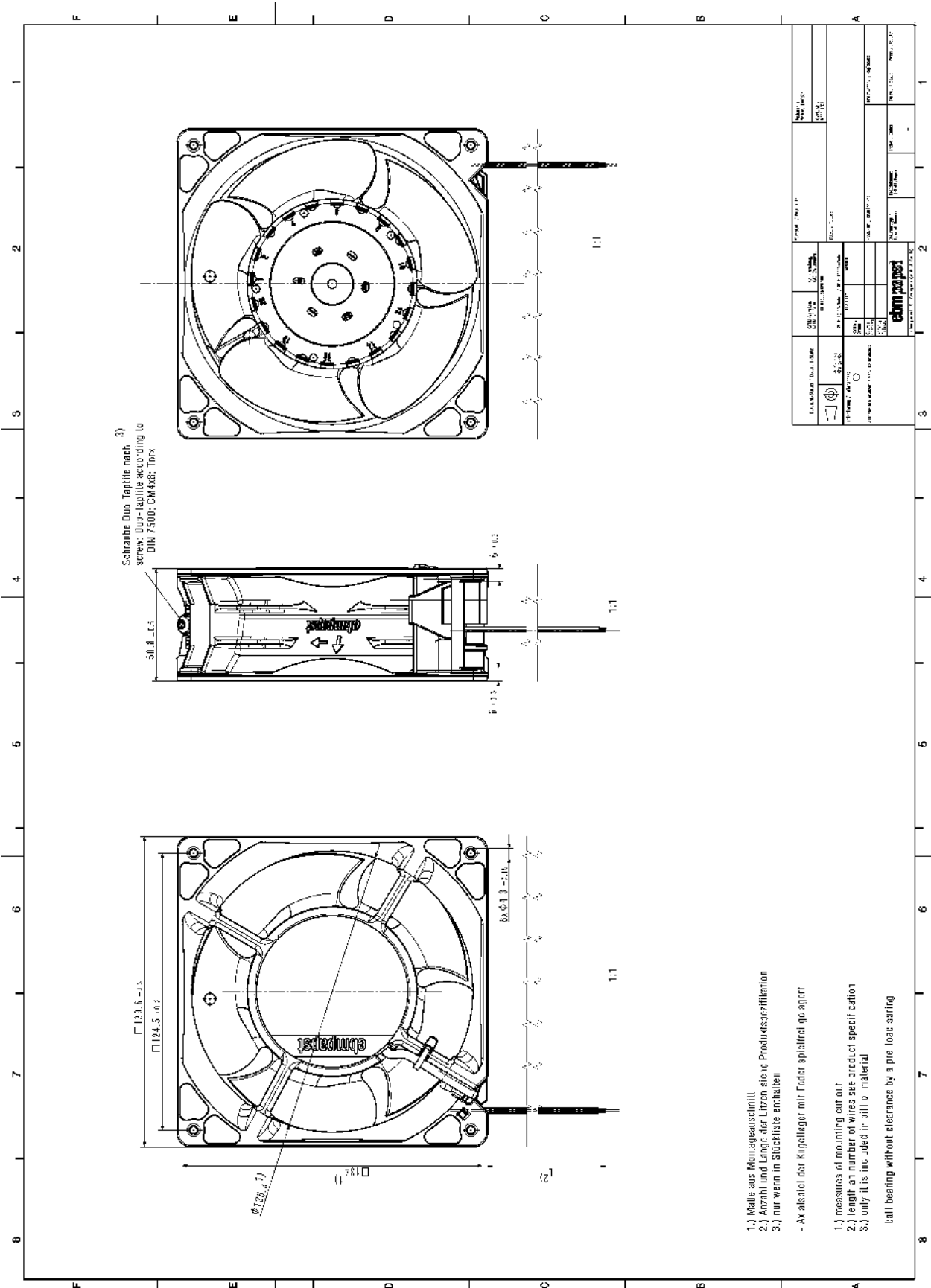

- 1.) Maße aus Montageauschnitt
 - 2.) Anzahl und Länge der Litzen siehe Produktspezifikation
 - 3.) nur wenn in Stückliste enthalten
- Ax alsstel dör Kugellager mit Feder spielfrei ge agert
- 1.) measures of mounting cut out
 - 2.) length and number of wires see product specification
 - 3.) only if it is included in bill of material
- ball bearing without clearance by a pre load spring

| | | | |
|--|--|--|--|
| Eigenschaften / Features | | Produkt / Product | |
| <ul style="list-style-type: none"> • 230V AC • 50/60 Hz • 0.12 A • 1.2 W • 120 mm x 120 mm x 50 mm • 120 mm x 120 mm x 50 mm | <ul style="list-style-type: none"> • 230V AC • 50/60 Hz • 0.12 A • 1.2 W • 120 mm x 120 mm x 50 mm • 120 mm x 120 mm x 50 mm | ebmpapst THE FAN COMPANY www.ebmpapst.com | |
| 1. 230V AC 2. 50/60 Hz 3. 0.12 A 4. 1.2 W 5. 120 mm x 120 mm x 50 mm 6. 120 mm x 120 mm x 50 mm | | 1. 230V AC 2. 50/60 Hz 3. 0.12 A 4. 1.2 W 5. 120 mm x 120 mm x 50 mm 6. 120 mm x 120 mm x 50 mm | |