

Product Data Sheet **9294310266**
VUCF119YJLS
4114 NU

ebmpapst

engineering a better life

4114NU (9294310266) ebmpapst Datasheet FansCo
sales@fansco.com
www.fansco.com



4114 NU

INDEX

1 General 3

2 Mechanics 3

2.1 General 3

2.2 Connections 3

3 Operating Data 4

3.1 Electrical Operating Data 4

3.2 Electrical Features 5

3.3 Aerodynamics 6

3.4 Sound Data 7

4 Environment 7

4.1 General 7

4.2 Climatic Requirements 7

5 Safety 9

5.1 Electrical Safety 9

5.2 Approval Tests 9

6 Reliability 9

6.1 General 9

1 General

| | | |
|-------------------------------------|------------------------|--|
| Fan type | Axial | |
| Rotating direction looking at rotor | Clockwise | |
| Airflow direction | Air intake over struts | |
| Bearing system | Ball bearing | |
| Mounting position - shaft | Any | |

2 Mechanics

2.1 General

| | | |
|---|---|--|
| Width | 119 mm | |
| Height | 119 mm | |
| Depth | 38 mm | |
| Mass | 0,400 kg | |
| Housing material | Metal | |
| Impeller material | Plastic | |
| Max. torque when mounted across both mounting flanges | Wire outlet corner: 450 Ncm Remaining corners: 600 Ncm | |
| Screw size | ISO 4762 - M4 degreased, without an additional brace and without washer | |

2.2 Connections

| | | |
|-----------------------|------------|--|
| Electrical connection | Wires | |
| Lead wire length | L = 310 mm | |
| Tolerance | +/- 10 mm | |

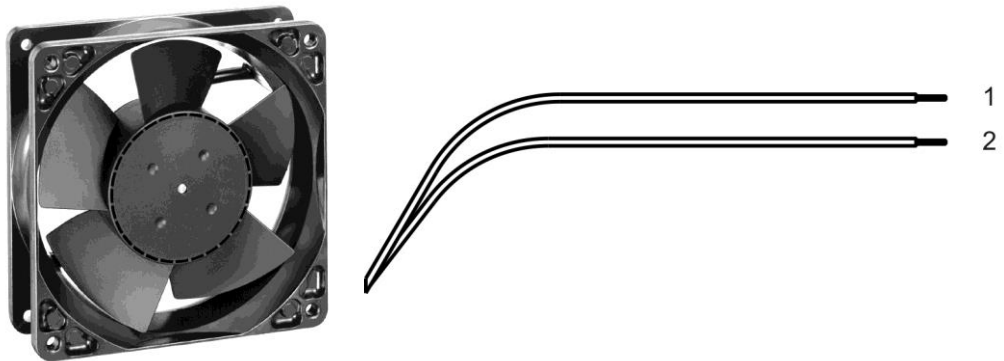

| Wire | Color | Operation | Wire size | Insulation diameter |
|------|-------|-----------|-----------|---------------------|
| 1 | red | + UB | AWG 22 | 1,7 mm |
| 2 | blue | - GND | AWG 22 | 1,7 mm |

3 Operating Data

3.1 Electrical Operating Data

Measurement conditions: Normal air density = 1,2 kg/m³; Temperature 23°C +/- 3°C; Motor axis horizontal; warm-up time before measuring 5 minutes (unless otherwise specified). In the intake and outlet area should not be any solid obstruction within 0,5 m.

$\Delta p = 0$: corresp. to free air flow (see chapter aerodynamics)
I: corresp. to arithm. mean current value

| Features | Condition | Symbol | Values | | |
|------------------------------|----------------|----------------|-------------|-------------|-------------|
| Voltage range | | U | 12 V | | 29 V |
| Nominal voltage | | U _N | | 24 V | |
| Power consumption | $\Delta p = 0$ | P | 1,3 W | 5 W | 8,7 W |
| Tolerance | 0010 | | +/- 17,5 % | +/- 12,5 % | +/- 15 % |
| Current consumption | $\Delta p = 0$ | I | 108 mA | 208 mA | 300 mA |
| Tolerance | 0010 | | +/- 17,5 % | +/- 12,5 % | +/- 15 % |
| Speed | $\Delta p = 0$ | n | 1.680 1/min | 3.200 1/min | 3.750 1/min |
| Tolerance | 0010 | | +/- 12,5 % | +/- 7,5 % | +/- 10 % |
| Starting current consumption | | | | 970 mA | |

3.2 Electrical Features

| | | |
|--------------------------------|-----------------------------------|--|
| Electronic function | None | |
| Reversed polarity protection | Rectifying diode | |
| Max. residual current at U_N | $I_F \leq 10 \text{ mA}$ | |
| Locked rotor protection | Auto restart | |
| Locked rotor current at U_N | I_{block} approx. 970 mA | |
| Clock signal at locked rotor | t_3 / t_4 typical: 0,6 s / 10 s | |

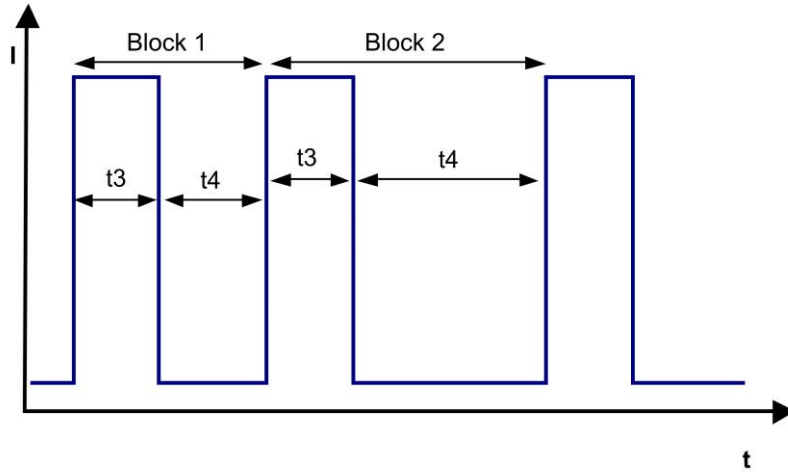

Block1: special locked rotor protection: 5 cycles $t_3 / t_4 = 0,6 \text{ s} / 1 \text{ s}$ Block2: locked rotor protection $t_3 / t_4 = 0,6 \text{ s} / 10 \text{ s}$

3.3 Aerodynamics

Measurement conditions: Measured with a double chamber intake rig acc. to DIN EN ISO 5801.
 Normal air density = 1,2 kg/m³; Temperature 23°C +/- 3°C;
 In the intake and outlet area should not be any solid obstruction within 0,5 m. Motor shaft horizontal.
 The information is only valid under the specified test conditions and may be changed by the installation conditions. If there are deviations from the standard test conditions, the characteristic values must be checked under the installed conditions.

a.) Operation condition:

3.200 1/min at free air flow

| | | |
|---|-------------------------|--|
| Max. free-air flow ($\Delta p = 0 / \dot{V} = \text{max.}$) | 168,0 m ³ /h | |
| Max. static pressure ($\Delta p = \text{max.} / \dot{V} = 0$) | 100 Pa | |

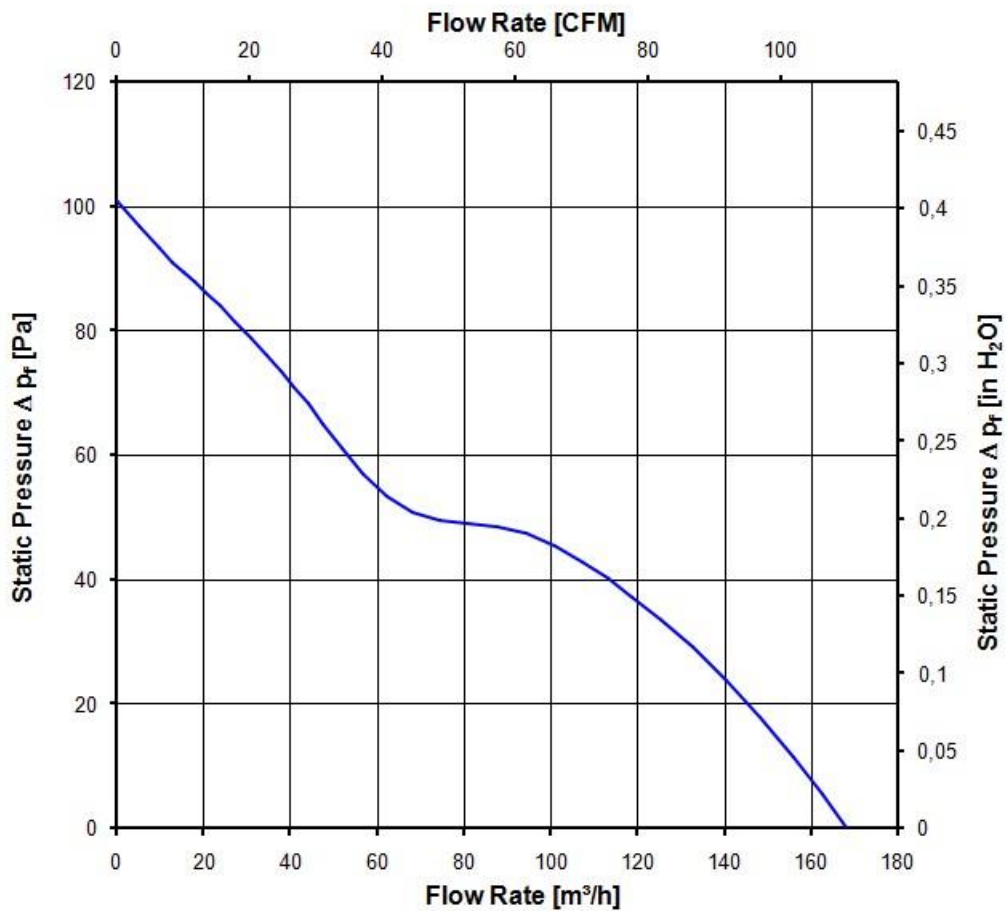

3.4 Sound Data

Measurement conditions: Sound pressure level: 1 meter distance between microphone and the air intake.
Sound power level: Acc. to DIN 45635 part 38 (ISO 10302)
Measured in a semianechoic chamber with a background noise level of $L_p(A) < 5 \text{ dB(A)}$
For further measurement conditions see chapter aerodynamics.

a.) Operation condition:

3.200 1/min at free air flow

| | | |
|---|---------------------------------|--|
| Optimal operating point | 104,0 m ³ /h @ 40 Pa | |
| Sound power level at the optimal operating point | 5,6 bel(A) | |
| Sound pressure level at free air flow, measured in rubber bands | 49,0 dB(A) | |

4 Environment

4.1 General

| | | |
|--|--------|--|
| Min. permitted ambient temperature TU min. | -20 °C | |
| Max. permitted ambient temperature TU max. | 75 °C | |
| Min. permitted storage temperature TL min. | -40 °C | |
| Max. permitted storage temperature TL max. | 80 °C | |

4.2 Climatic Requirements

| | | |
|--------------------------------|---|--|
| IP-protection type (certified) | IP 68 (for fan only, not for connector if applicable) **) | |
| Humidity requirements | humid temperature, cyclic; according to DIN EN 60068-2-38, 10 cycle and condensation water check; according to DIN EN ISO 6270-2, 14 days | |
| Salt fog requirements | None | |

Permitted application area:

The product is for the use in partial sheltered rooms or open, roofed areas. Direct exposure to water is allowed provided that this does not prevent the normal operation. Saline ambient conditions must be avoided.

Pollution degree 3 (according DIN EN 60664-1)

It occurs conductive pollution or dry non-conductive pollution which becomes conductive due to condensation.

**) The specification of the IP protection refers to the conditions mentioned in certification of the fan. The above mentioned short description of the protection scope is not final. For detailed information of the respective protection scope and definitions, see certification as well as DIN EN 60529 (protection by housings) and ISO 20653 (for vehicles) with the letter K.

Short description of the IP-protection type:

Solid particle Protection: Dust tight.

Protection against deliberate contact: Protected against contact to hazardous parts with a wire.

Protection against water: The fan test according to IP68 (Based on IEC 60529), is conducted in non-operating mode. The fan is tested by a complete immersion in water for a period of 2h at a water-level of 1,2m. Electrical connections are not immersed since they are customer specific.

Please require severity levels and specification parameters from the responsible development departments.

5 Safety**5.1 Electrical Safety**

| | | |
|---|--|--|
| Dielectric strength DIN EN 62368 and DIN EN 60335 A.) Type test Measuring conditions: After 48h of storage at 95% R.H. and 25°C. No arcing or breakdown is allowed! All connections together to ground. B.) Routine test Measuring conditions: At indoor climate. No arcing or breakdown is allowed! All connections together to ground. | 500 VAC / 1 Min. 850 VDC / 1 Sec. | |
| Isolation resistance Measuring conditions: After 48h of storage at 95% R.H. and 25°C measured with U=500 VDC for 1 min. | RI > 10 MOhm | |
| Clearance / creepage distance | 1,0 mm / 1,2 mm | |
| Protection class | III | |

5.2 Approval Tests

| | | |
|-----|---|---|
| CE | EC Declaration of Conformity | Yes |
| EAC | Eurasian Conformity | Yes |
| UL | Underwriters Laboratories | Yes / UL507, Electric Fans E38324 |
| VDE | Association for Electrical, Electronic and Information Technologies | Yes / Approval acc. to EN 62368 - Audio/video, information and communication technology equipment |
| CSA | Canadian Standards Association | Yes / C22.2 No. 113 Fans and Ventilators |
| CCC | China Compulsory Certification | Not applicable |

6 Reliability**6.1 General**

| | | |
|--|-----------|--|
| Life expectancy L10 at TU = 40 °C | 85.000 h | |
| Life expectancy L10 at TU max. | 32.500 h | |
| Life expectancy L10 acc. to IPC 9591 at TU = 40 °C | 142.500 h | |

Copying of this document and giving it to others and the use or communication of the contents thereof, are forbidden without express authority. Offences are liable to the payment of damages. All rights are reserved in the event of a patent or the registration of a utility model or design.

Schutzvermerk nach DIN ISO 9100, beachten/ Refer to protection notice DIN ISO 9100

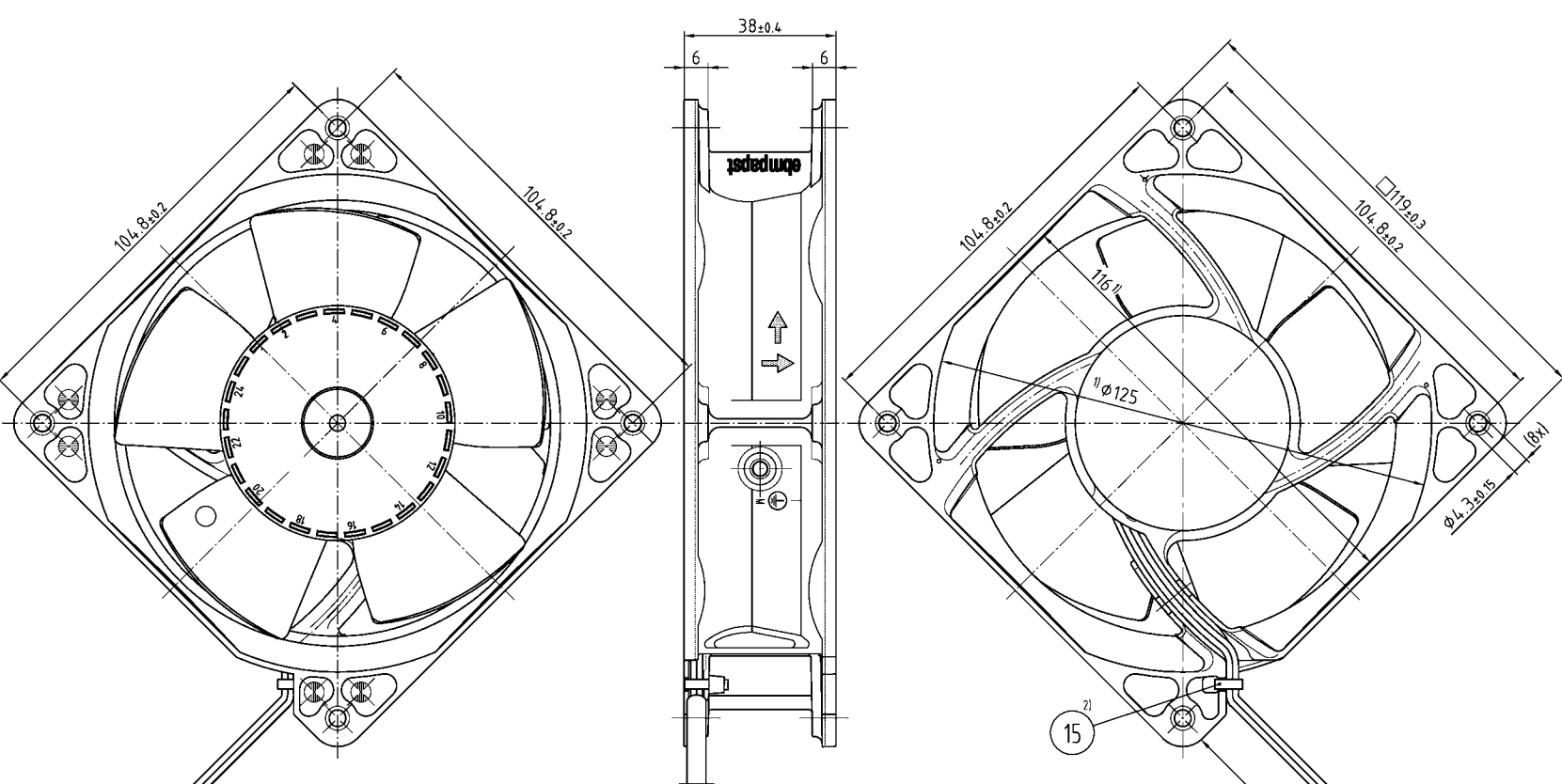

- 1)- Maße für Montagewand
- Axialspiel bei Kugellagerung (K) : 0 (durch Federausgleich)
- Axialspiel bei Gleitlagerung (G) : 0,1 bis 0,6
- 2)- Mit Handhabungswerkzeug montiert,
- Kopf darf nach Montage nicht über Außenkontur des Lüftergehäuses stehen

- 1)- Measures for prefab wall
- Axial play with ball bearing (K): 0 (by spring compensation)
- Axial play with sleeve bearing (G): 0,1 to 0,6
- 2)- With handling tool installed,
- Head may not stand over outer contour of the fan housing after assembly

Leitungslänge siehe Produktspezifikation
For conduit length see product specification

| | | | | | |
|--------------------------------------|---------------------|------------------------|--|------------------------------|-----------------------------------|
| SAP-Status/State | Änd.-Nr./Change-No. | Aut/CAD-System-Version | ebmpapst CAD-Umgebung/ CAD-Environment | Werkstoff/Material: | Volumen/Volume (mm ³) |
| | | Datum/Date | Name/Name | | Gewicht/Mass (g): |
| | | Bearb./ Drawn | | Artikel/Title | |
| Tolerierung/Tolerances: | | Gepr./ Checked | | axial compact fan | |
| Allgemeintoleranzen/Gen. tolerances: | | Freig./ Released | | Zchg.-Nr./ Drawing-No.: | Ers.f.Zchg./ Replaces |
| DIN ISO 2768-1 u. 2-mK | | | ebmpapst | | |
| | | | ebm-papst St. Georgen GmbH & Co. KG | Dokumenttyp/Type of Document | Teildokument Blatt/Sheet |
| | | | | Index/Index | Format/Size |
| | | | | | Massstab/Scale |

11/09