

Product Data Sheet **8315100070**
VWLJ225XJLVZ
2214/2 TDHO

ebmpapst

engineering a better life



2214/2 TDHO

INDEX

1 General 3

2 Mechanics 3

2.1 General 3

2.2 Connections 3

3 Operating Data 5

3.1 Electrical Interface - Input 5

3.2 Electrical Operating Data 7

3.3 Electrical Interface - Output 8

3.4 Electrical Features 9

3.5 Aerodynamics 10

3.6 Sound Data 11

4 Environment 11

4.1 General 11

4.2 Climatic Requirements 11

4.3 EMC 11

5 Safety 13

5.1 Electrical Safety 13

5.2 Approval Tests 13

6 Reliability 13

6.1 General 13

1 General

Fan type	Axial	
Rotating direction looking at rotor	Counterclockwise	
Airflow direction	Air outlet over struts	
Bearing system	Ball bearing	
Mounting position - shaft	Any	

Please note:

Sensorless commutation electronic, starting at the first start may not be 100% guaranteed, automatic restart occurs.

2 Mechanics**2.1 General**

Width	225 mm	
Height	225 mm	
Depth	80 mm	
Diameter	260 mm	
Mass	1,48 kg	
Housing material	Metal	
Impeller material	Plastic	
Max. torque when mounted across both mounting flanges Screw size	Wire outlet corner: 600 Ncm Remaining corners: 600 Ncm ISO 4762 - M4 degreased, without an additional brace and without washer	

2.2 Connections

Electrical connection	Wires	
Lead wire length	See drawing	
Tolerance		

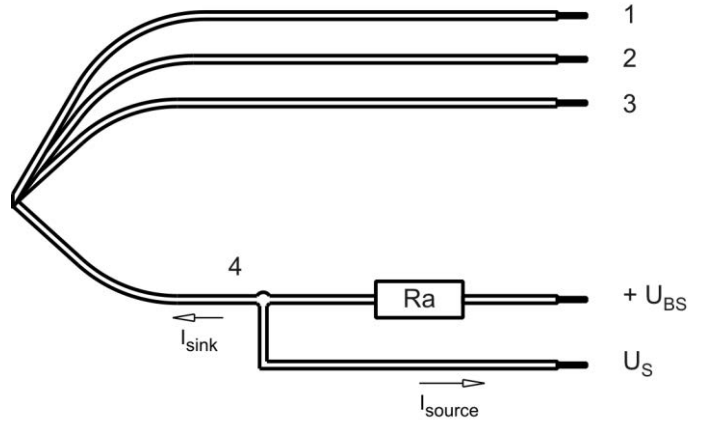

Wire	Color	Operation	Wire size	Insulation diameter
1	red	+ UB	AWG 20	2,05 mm
2	blue	- GND	AWG 20	2,05 mm
3	white	Tacho	AWG 22	1,7 mm
4	violet	CTRL	AWG 22	1,7 mm

The auxiliaries shown on the schematic diagram (which are required for the intended use) are not part of our delivery.

3 Operating Data

3.1 Electrical Interface - Input

Control input	Analog
---------------	--------

Features

PWM - Frequency	1 kHz - 10 kHz typical: 2 kHz
Input voltage range	0 V - 10 V

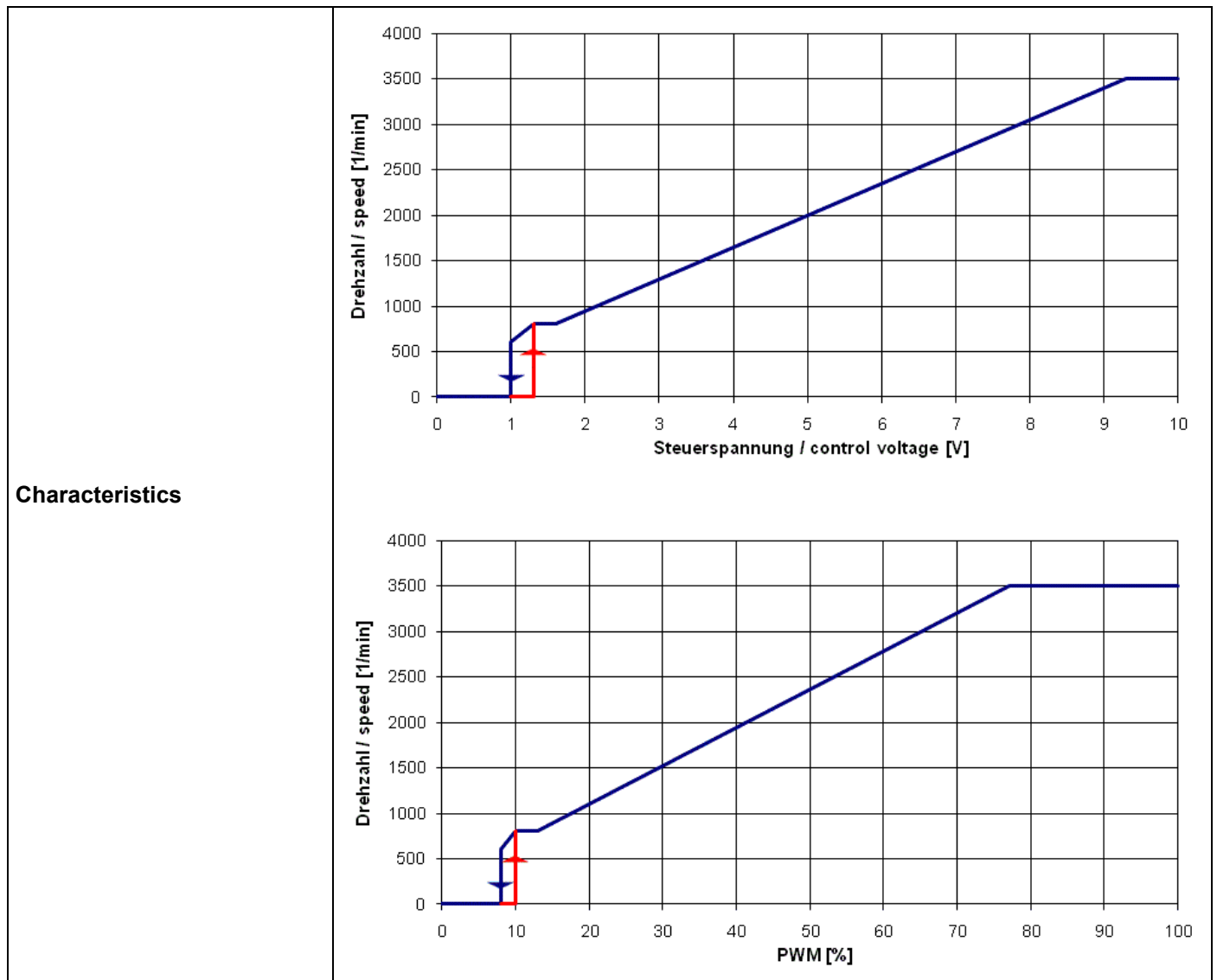

Schematics

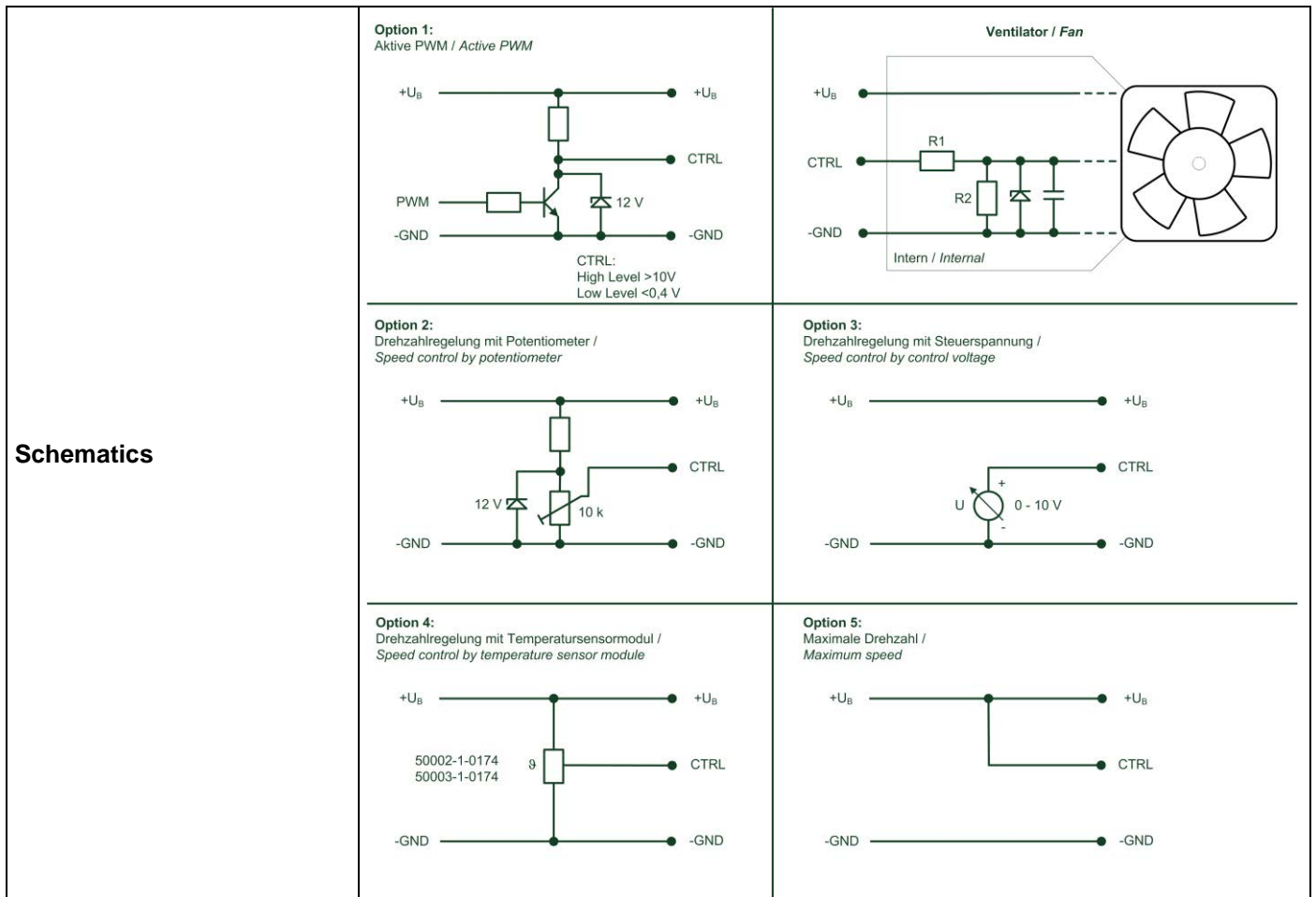

Input voltage divider:

R1 = 47 kOhm
 R2 = 36 kOhm
 For protection: There is parallel to R2 a 5,1 V Z-Diode

Speed control:

By pulse-width modulation (PWM) 0 ... 100%
 with switching transistor in emitter circuit and collector resistance to 12 V
 Frequency = 2 kHz (1 - 10 kHz)

Information to the curve PWM:

0% - <10% PWM: 0 1/min
 10% PWM: 800 1/min (Fan on, coming from 0% PWM)
 10% - 13% PWM: 800 1/min (corresponding to min. speed)
 13% - 78% PWM: linear increasing curve
 78% - 100% PWM: 3.500 1/min (corresponding to max. speed)
 10% - >8% PWM: linear decreasing curve (coming from 100% PWM)
 8% PWM: 600 1/min or 0 1/min (Fan off, coming from 100% PWM)

or:

Speed control:

By analog voltage 0 - 10 V

Information to the curve analog:

0 V - < 1,3 V:	0 1/min
1,3 V:	800 1/min (Fan on, coming from von 0 V)
1,3 V - 1,6 V:	800 1/min (corresponding to min. speed)
1,6 V - 9,4 V:	linear increasing curve
9,4 V - 10 V:	3.500 1/min (corresponding to max. speed)
1,3 V - > 1,0 V:	linear decreasing curve (coming from 10 V)
1,0 V:	600 1/min or 0 1/min (Fan off, coming from 10 V)

All measurement values are measured in the housing!

Fan has no sensor break detection!

3.2 Electrical Operating Data

Measurement conditions: Normal air density = 1,2 kg/m³; Temperature 23°C +/- 3°C; Motor axis horizontal; warm-up time before measuring 5 minutes (unless otherwise specified). In the intake and outlet area should not be any solid obstruction within 0,5 m.

$\Delta p = 0$: corresp. to free air flow (see chapter aerodynamics)
 I: corresp. to arithm. mean current value

Name	Condition
U Contr. 0001	U Contr.: 10 V

Features	Condition	Symbol	Values		
Voltage range		U	16 V		36 V
Nominal voltage		U _N		24 V	
Power consumption	$\Delta p = 0$	P	50 W	70 W	72 W
Tolerance	U Contr. 0010		+/- 10 %	+/- 10 %	+/- 10 %
Current consumption	$\Delta p = 0$	I	3.100 mA	2.900 mA	2.000 mA
Tolerance	U Contr. 0010		+/- 10 %	+/- 10 %	+/- 10 %
Speed	$\Delta p = 0$	n	3.150 1/min	3.500 1/min	3.500 1/min
Tolerance	U Contr. 0010		+/- 10 %	+/- 5 %	+/- 5 %
Starting current consumption				3.100 mA	

3.3 Electrical Interface - Output

Tacho type	/2 (open collector)
------------	---------------------

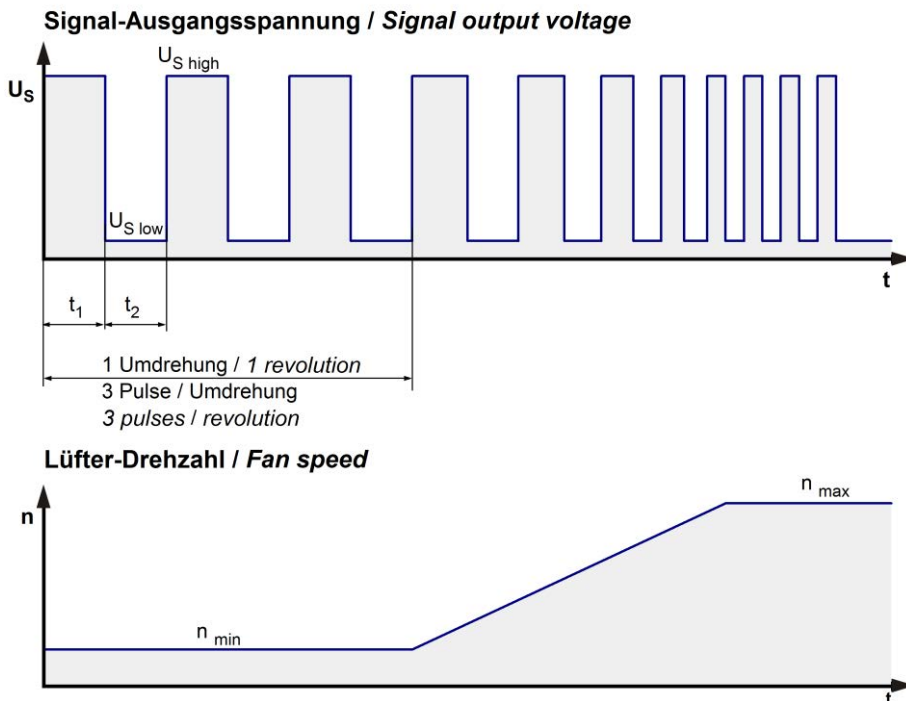

$$R_a = \frac{U_{BS} - U_{S\ low}}{I_{sink}}$$

Lüfter / Fan Kunde / Customer

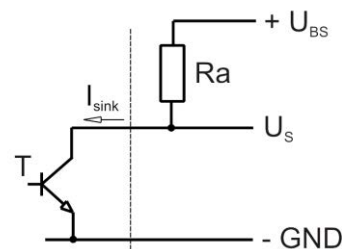

Features	Note	Values
Tacho operating voltage	U_{BS}	$\leq 36\text{ V}$
Tacho signal Low	$U_{S\ low}$	$I_{sink}: 2\text{ mA}$ $\leq 0,4\text{ V}$
Tacho signal High	$U_{S\ high}$	$I_{source}: 0\text{ mA}$ $\leq 36\text{ V}$
Maximum sink current	I_{sink}	$\leq 20\text{ mA}$
Maximum source current		0 mA
External resistor	External resistor R_a from U_{BS} to U_S required. All voltages measured to GND.	
Tacho frequency	$(3 \times n) / 60$	$175\text{ Hz @ } 3.500\text{ 1/min}$
Tacho isolated from motor	No	
Slew rate		$\geq 0,5\text{ V/us}$

n = revolutions per minute (1/min)

Please note:

At zero speed the tacho signal is at a static HIGH. It will be also HIGH when the fan is still spinning, but the speed control signal is set to zero speed already.
 The tacho signal is only activated after the start-up is completed.

3.4 Electrical Features

Electronic function	Speed-Controlled	
Reversed polarity protection	Rectifying diode	
Max. residual current at U_N	$I_F \leq 5 \text{ mA}$	
Locked rotor protection	Auto restart	
Locked rotor current at U_N	I_{block} approx. 2.800 mA	
Clock signal at locked rotor Extended Downtime	t_3 / t_4 typical: 5,2 s / 10,0 s t_5 : 40 s after 4 start-up tests	
Internal fuse	Littelfuse NANO2 > Very Fast-Acting > 451/453 Series 10A / 125V (Art.No.: 0451010.MRL)	
Voltage control *)	Fan turns on at $U_B > 14 \text{ V}$ or $< 40 \text{ V}$ Fan turns off at $U_B < 12 \text{ V}$ or $> 42 \text{ V}$	

*) This fan has an undervoltage and overvoltage control circuit integrated which turns the motor off if the voltage is out of range.

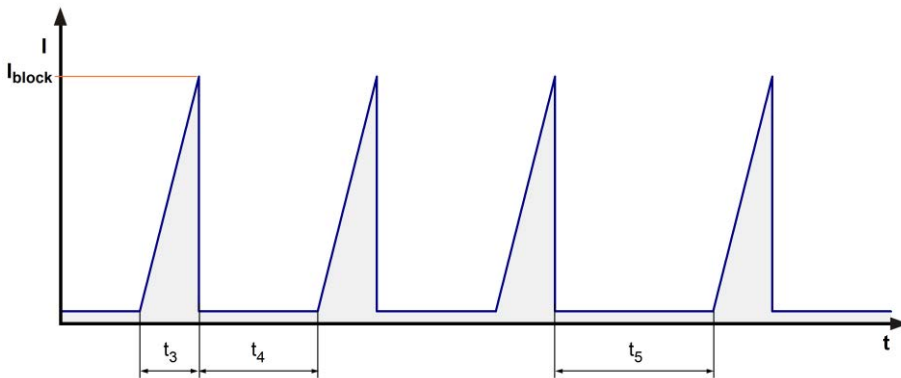

3.5 Aerodynamics

Measurement conditions: Measured with a double chamber intake rig acc. to DIN EN ISO 5801. Normal air density = 1,2 kg/m³; Temperature 23°C +/- 3°C; In the intake and outlet area should not be any solid obstruction within 0,5 m. Motor shaft horizontal.

The information is only valid under the specified test conditions and may be changed by the installation conditions. If there are deviations from the standard test conditions, the characteristic values must be checked under the installed conditions. Power consumption of the fan motor when operating at normal voltage is shown. Depending on the operating conditions of the application, the power input may be higher.

a.) Operation condition:

3.500 1/min at free air flow	U Contr. 10 V		
------------------------------	---------------	--	--

Max. free-air flow ($\Delta p = 0 / \dot{V} = \text{max.}$)	1.152 m ³ /h	
Max. static pressure ($\Delta p = \text{max.} / \dot{V} = 0$)	400 Pa	

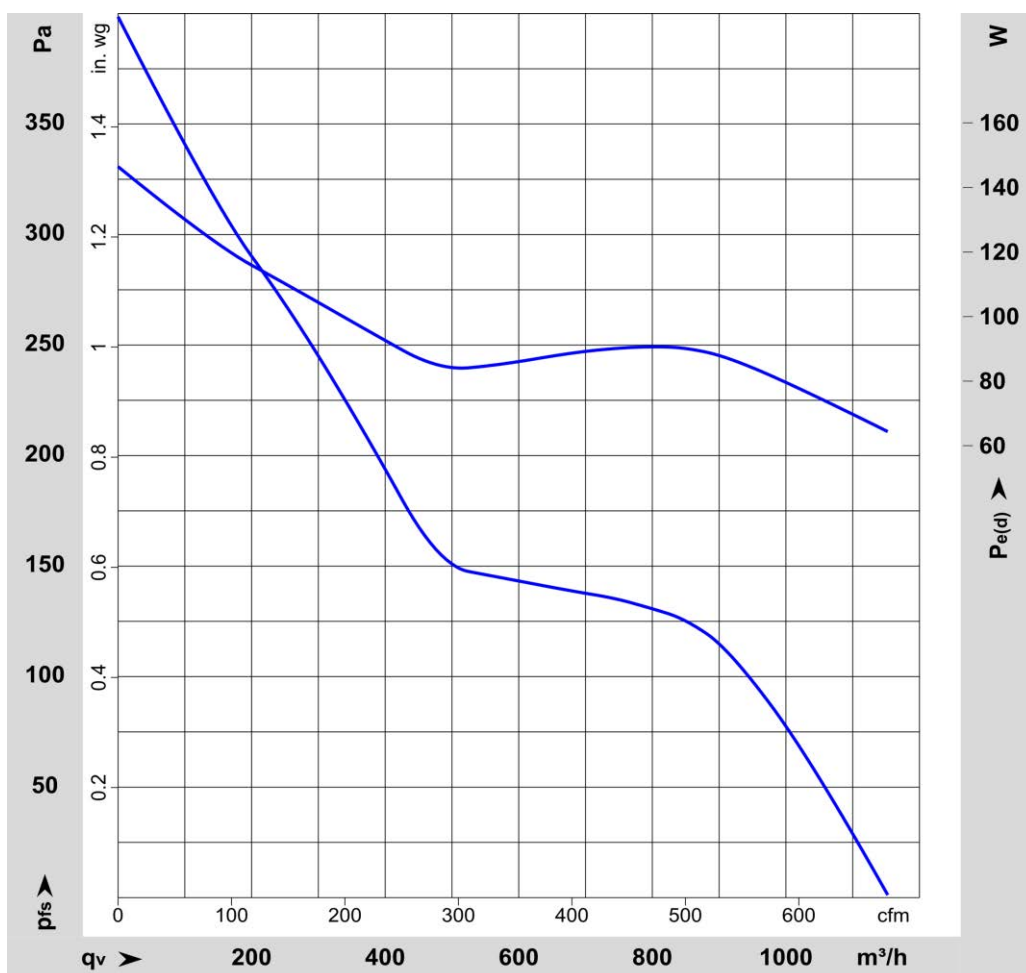

3.6 Sound Data

Measurement conditions: Sound pressure level: 1 meter distance between microphone and the air intake.
Sound power level: According to ISO 13347-3.
Measured in a semianechoic chamber with a background noise level of $L_p(A) < 5 \text{ dB(A)}$
For further measurement conditions see chapter aerodynamics.

a.) Operation condition:

3.500 1/min at free air flow	U Contr. 10 V		
------------------------------	---------------	--	--

Optimal operating point	1.152 m ³ /h @ 0 Pa		
Sound power level at the optimal operating point	7,3 bel(A)		
Sound pressure level at free air flow, measured in rubber bands	63 dB(A)		

4 Environment

4.1 General

Min. permitted ambient temperature TU min.	-20 °C		
Max. permitted ambient temperature TU max.	65 °C		
Min. permitted storage temperature TL min.	-40 °C		
Max. permitted storage temperature TL max.	80 °C		

4.2 Climatic Requirements

Humidity requirements	humid heat, constant; according to DIN EN 60068-2-78, 14 days		
Water exposure	None		
Dust requirements	None		
Salt fog requirements	None		

Permitted application area:

The product is intended for use in sheltered rooms with controlled temperature and controlled humidity. Directly exposure to water must be avoided.

Pollution degree 1 (according DIN EN 60664-1)

There is either no pollution or it occurs only dry, non-conductive pollution. The pollution has no negative impact.

Please require severity levels and specification parameters from the responsible development departments.

4.3 EMC

Kind	Conducted Emission; Voltage; 150 kHz-30 MHz
According	DIN EN 55032:2016-02
Check accuracy / Limit	Class B
Result	Below limit Class B

Kind	Radiated Emission; 30 MHz - 1000 MHz
According	DIN EN 55032:2016-02
Check accuracy / Limit	Class B
Result	Below limit Class B

Kind	Electrostatic Discharge Immunity Test
According	DIN EN 61000-4-2:2001-12
Check accuracy / Limit	Contact Discharge +/- 4 kV; Air Discharge +/- 8 kV
Result	A: The monitored function operates as designed during and after exposure to a disturbance.

Kind	Electromagnetic Field Immunity Test
According	DIN EN 61000-4-3:2006-12
Check accuracy / Limit	10 V/m; 80 - 1000 MHz; AM; m = 0,8; f = 1 kHz; 1%; t = 3 s
Result	A: The monitored function operates as designed during and after exposure to a disturbance.

Kind	Electrical Fast Transient / Burst Immunity Test
According	DIN EN 61000-4-4:2005-07
Check accuracy / Limit	+/- 2 kV on Power Lines; Coupling: POS, NEG, {PE}, ALL, 5 kHz and 100 kHz; 1 min
Result	A: The monitored function operates as designed during and after exposure to a disturbance.

Kind	Immunity to Conducted Disturbances, Induced by RF-Fields
According	DIN EN 61000-4-6:2001-12
Check accuracy / Limit	10 Vrms; 150 kHz - 80 MHz; AM; m = 0,8; f = 1 kHz; 1%; t = 3 s
Result	A: The monitored function operates as designed during and after exposure to a disturbance.

5 Safety**5.1 Electrical Safety**

Dielectric strength DIN EN 62368 and DIN EN 60335 A.) Type test Measuring conditions: After 48h of storage at 95% R.H. and 25°C. No arcing or breakdown is allowed! All connections together to ground. B.) Routine test Measuring conditions: At indoor climate. No arcing or breakdown is allowed! All connections together to ground.	500 VAC / 1 Min. 850 VDC / 1 Sec.	
Isolation resistance Measuring conditions: After 48h of storage at 95% R.H. and 25°C measured with U=500 VDC for 1 min.	RI > 10 MOhm	
Clearance / creepage distance	1,0 mm / 1,2 mm	
Protection class	III	

5.2 Approval Tests

CE	EC Declaration of Conformity	Yes
EAC	Eurasian Conformity	Yes
UL	Underwriters Laboratories	Yes / UL507, Electric Fans E38324
VDE	Association for Electrical, Electronic and Information Technologies	Yes / Approval acc. to EN 62368 - Audio/video, information and communication technology equipment
CSA	Canadian Standards Association	Yes / CSA audited by UL according to C22.2 No. 113 Fans and Ventilators
CCC	China Compulsory Certification	Not applicable

6 Reliability**6.1 General**

Life expectancy L10 at TU = 40 °C	80.000 h	
Life expectancy L10 at TU max.	45.000 h	
Life expectancy L10 acc. to IPC 9591 at TU = 40 °C	135.000 h	

Dimensional Drawing

Typ: 8315100070

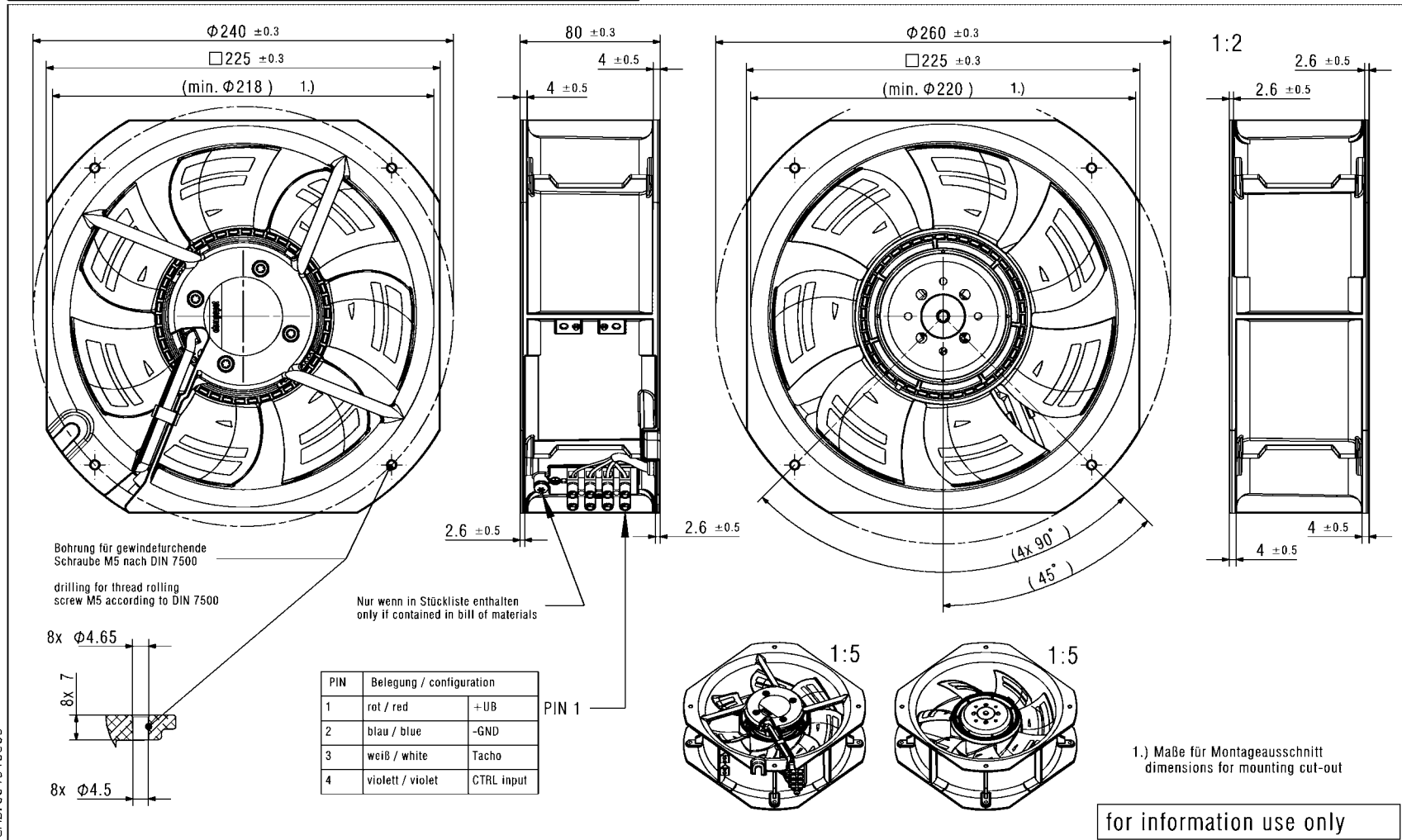

CAD: 004345803

ebmpapst

ebm-papst St. Georgen GmbH & Co. KG

Date: 13.01.20 | Designed: A.Fleig

Any unauthorised use of this drawing, copying or passing on to third parties requires the explicit approval of ebm-papst St. Georgen GmbH & Co. KG. Any violations of this shall be prosecuted in court and penal court.

Dre